



KAPPELER INSTITUTE RECORDINGS

ILLUSTRATIVE MATERIAL

THE B-SERIES*

B-2, From Atomistic Thinking to Cybernetic Comprehensive Consciousness

B-3, Christian Science Practice: Based on the Science of divine revelation

B-6I, Fundamental Questions on the Science of Christians Science (Part 1):

The Steps from Metaphysics to Science

B-6II, Fundamental Questions on the Science of Christians Science (Part 2):

Advancing Spiritual Consciousness

B-6III, Fundamental Questions on the Science of Christians Science (Part 3):

The Christ

B-6IV, Ascending and Descending in the 4 Levels of Science

B-6V, Structural Consciousness

MAX KAPPELER

***Audio Codes for this set include: B-2, B-3, B-6I, B-6II, B-6III, B-6IV, B-6V**



KAPPELER INSTITUTE RECORDINGS

ILLUSTRATIVE MATERIAL

**FROM ATOMISTIC THINKING
TO
CYBERNETIC COMPREHENSIVE CONSCIOUSNESS
(Audio code B-2)**

Max Kappeler

©1970, ©2005, Kappeler Institute for the Science of Being
All rights reserved



Kappeler Institute Publishing
P.O. Box 99735
Seattle, WA 98139-0735
Tel: (206)286-1617 • Fax: (206) 286-1675
mail@kappelerinstitute.org
www.kappelerinstitute.org
Division of Kappeler Institute for the Science of Being, USA
Seattle, WA USA

Contents

From Atomistic Thinking to Cybernetic Comprehensive Consciousness

(Audio code: B-2)

©1970, 2005 Kappeler Institute for the Science of Being

AUDIO RECORDING NUMBER/SIDE	RECORDING SUBJECT
1-A	Introduction <ul style="list-style-type: none">• Going out from the problem• Going out from the Infinite One
1-B	Atomistic Thinking <ul style="list-style-type: none">• Definitions of Science• Development of consciousness
2-A	Linear Thinking <ul style="list-style-type: none">• The law of creativity in the seven days of creation
2-B	<ul style="list-style-type: none">• The law of creativity in evolution
3-A	...continued <ul style="list-style-type: none">• The 7,000 year-period in the Bible• The development of Jesus' life• The numerals of infinity versus the days of creation
3-B	...continued
	Functional Thinking
4-A	<ul style="list-style-type: none">• Blending of ideas• Subtones of the days of creation• Thoughts versus ideas
4-B	<ul style="list-style-type: none">• The synonymous terms• The nature and essence of God
EDITOR'S NOTE:	After Tape 4-B ends, there should be an additional 10 minutes or so of recording. See pg. 43 of the B-2 Illustrative Material for a written transcription of this lost section of tape.
5-A	Review <ul style="list-style-type: none">• All ideas reflect every other idea
5-B	...continued <ul style="list-style-type: none">• The synonymous terms reflecting the four
6-A	<ul style="list-style-type: none">• The synonymous terms and their counterfeits• Concept-building
6-B	...continued <ul style="list-style-type: none">• Principle and its idea

From Atomistic Thinking to Cybernetic Comprehensive Consciousness – Audio Code B-2

© 1970, 2005 Kappeler Institute for the Science of Being, PO Box 99735, Seattle, WA 98139-0735. All rights reserved.

7-A	...continued
	Going out from a system of reference
	Operational consciousness
	<ul style="list-style-type: none"> • Word, Christ, Christianity, and Science
7-B	...continued
8-A	<ul style="list-style-type: none"> • The four Gospels reflecting the Word, Christ, Christianity, and Science • The law of creativity in the Word-order
8-B	<ul style="list-style-type: none"> - Christ-order - Christianity-order
9-A	...continued
9-B	<ul style="list-style-type: none"> - Science-order
10-A	...continued
10-B	<ul style="list-style-type: none"> • The Word, Christ, Christianity, and Science-order in the Bible
	...continued
	Structural Consciousness
	<ul style="list-style-type: none"> • The synonym Matrix
11-A	<ul style="list-style-type: none"> • The Platform • The Word-Matrix – John Doorly’s Matrix
11-B	...continued
	<ul style="list-style-type: none"> • The Christ-Matrix – The Minor Prophets
12-A	...continued
12-B	...continued
	<ul style="list-style-type: none"> • The Christianity-Matrix – The Epistles
13-A	...Review
	<ul style="list-style-type: none"> • The Science-Matrix – The Textbook
13-B	...continued
14-A	...continued
14-B	...continued
	<ul style="list-style-type: none"> • The Mind-Matrix
15-A	...continued
15-B	<ul style="list-style-type: none"> • The Matrix of Handling Evil
16-A	...continued
	<ul style="list-style-type: none"> • How to put the laws into today’s language
16-B	...continued
17-A	...continued

The dimensional consciousness

17-B	<ul style="list-style-type: none"> • The four levels of spiritual consciousness <ul style="list-style-type: none"> – The level of Christian Science – The level of absolute Christian Science – The level of divine Science and Science itself
18-A	<ul style="list-style-type: none"> • What these levels handle ...continued • The ascending and the descending thought
18-B	<ul style="list-style-type: none"> ...continued • The tonality of the levels • Evil in the aspect of the levels
19-A	<ul style="list-style-type: none"> ...continued • The levels and their synonymous terms <ul style="list-style-type: none"> – The synonymous terms in divine Science
19-B	<ul style="list-style-type: none"> ...continued – The synonymous terms in absolute Christian Science
20-A	<ul style="list-style-type: none"> ...continued – The synonymous terms in Christian Science
20-B	<ul style="list-style-type: none"> • Healing ...continued
	Cybernetic consciousness
21-A	<ul style="list-style-type: none"> • Input, process, output, feedback
	Comprehensive consciousness
21-B	<ul style="list-style-type: none"> • Oneness in the Old Testament • Oneness in the New Testament • Oneness from the point of view of Principle <ul style="list-style-type: none"> – As the Word – As the Christ ...continued – As Christianity – As Science
22-A	<ul style="list-style-type: none"> ...continued • Oneness in the Textbook <ul style="list-style-type: none"> – The Word-chapters – The Christ-chapters – Christianity-chapters – The Science-chapters
22-B	<ul style="list-style-type: none"> ...continued
23-A	<ul style="list-style-type: none"> ...continued
23-B	Ordered steps of finding oneness with Being
24-A	<ul style="list-style-type: none"> ...continued ...continued

24-A cont.	The development of the chapter on Animal Magnetism
24-B	Mind-edition <ul style="list-style-type: none">• Spirit-edition• Soul-edition• Principle-edition• Life-edition• Truth-edition• Love-edition
25-A	The development of Christian Science
25-B	<ul style="list-style-type: none">• Phineas P. Quimby's influence• Edward Kimball's influence• Bicknell Young's influence• John W. Doorly's teaching
26-A	...continued <ul style="list-style-type: none">• Brief Summary

**From Atomistic Thinking
to Cybernetic Comprehensive Consciousness**

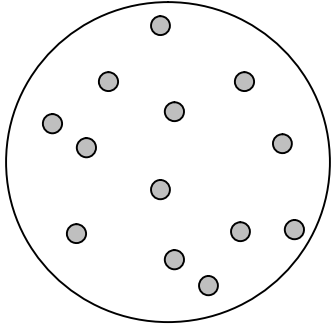

Unrelated

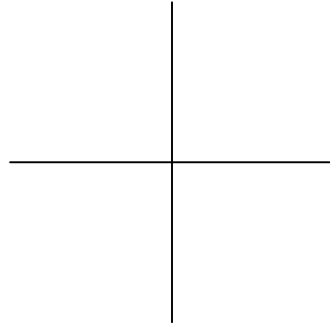

Intersection of Vertical and
Horizontal Categories

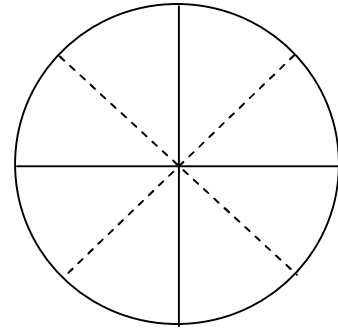

Each Point
Related

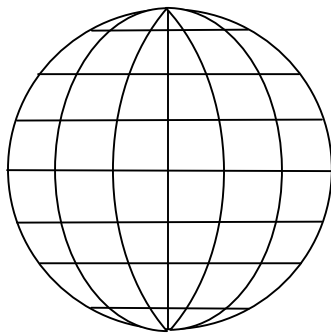

Superimposed
Network on Globe

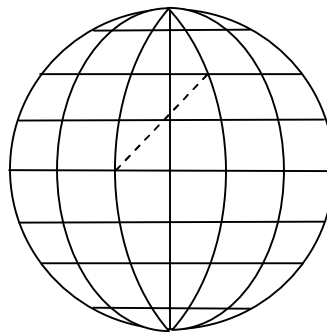

Relationship
of Points

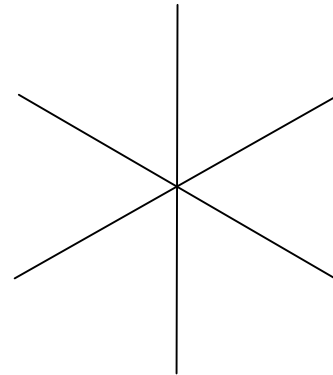

All Ideas
Connected

Law of Creativity

Days of Creation	3rd Degree (S&H 116)			Synonyms for God (S&H 465)
light: intelligence	wisdom	creative ability	law	Mind
firmament: separation	purity	unfoldment	order	Spirit
earth, seed in itself: identity	spiritual understanding	identity	rule	Soul
sun, moon, stars: government	spiritual power	classification	system	Principle
moving creatures: life	love	individuality	method	Life
man: dominion	health	consciousness	form	Truth
rest: fulfillment	holiness	unity with God	plan or design	Love

Model of Being (The Chart)

Science itself	infinite Principle													
	Word	Christ	Christianity	Science										
divine Science	Life	Truth	Love	divine Principle, Love										
absolute Christian Science	Life Truth Love	Truth Life Love	Life Love	Truth Love										
Christian Science	Mind	Principle Life Truth Love Soul Spirit Mind	Principle Mind Soul Spirit Life Truth Love	<table style="margin: auto; border: none;"> <tr> <td colspan="2">Principle</td> </tr> <tr> <td>Soul</td> <td>Life</td> </tr> <tr> <td>Spirit</td> <td>Truth</td> </tr> <tr> <td>Mind</td> <td>Love</td> </tr> <tr> <td colspan="2">Principle</td> </tr> </table>	Principle		Soul	Life	Spirit	Truth	Mind	Love	Principle	
Principle														
Soul	Life													
Spirit	Truth													
Mind	Love													
Principle														
	Spirit													
	Soul													
	Principle													
	Life													
	Truth													
	Love													

The 7 Synonymous Terms for God (in Word-order): **Mind, Spirit, Soul, Principle, Life, Truth, Love**

The 4-fold Operation of Being: **Word, Christ, Christianity, Science**

The 4 Levels of Spiritual Consciousness: **Science itself, divine Science, absolute Christian Science, Christian Science**

The Thousand-Year Periods of the Bible

The thousand-year periods of the Bible show how the ordered nature of God provides the step-by-step way out of belief and ignorance to a spiritual understanding of God, bringing life and peace.

synonym	1000-year period (symbol)	steps of unfolding understanding
Mind	Adam to Enoch (c. 4000 – 3000 B.C.)	awakening from ignorance (the mist of Eden) to follow the light of spiritual ideas (Enoch walks with God)
Spirit	Noah story with the flood to tower of Babel (c. 3000 – 2000 B.C.)	turning away from material beliefs to build an “ark” of understanding, remaining with the purity and onliness of spiritual ideas
Soul	Abraham, Isaac, Jacob, Joseph into Egypt, Moses leading people out of Egypt, entering the Promised Land, Joshua, Judges (c. 2000 – 1000 B.C.)	going the way from sense (Ur, Egypt) to Soul (Canaan, the Promised Land), exchanging a physical, corporeal identity for our spiritual selfhood
Principle	Samuel to the kings; the prophets (c. 1000 B.C. – 1 A.D.)	rejecting government by persons or material organizations and finding true government through prophecy, through the operation of Principle’s system of ideas, which interprets itself to mankind and governs the universe
Life	the life of Jesus, the apostles, Paul and the spreading of Christianity (c. 1 – 1000 A.D.)	laying down a mortal, material sense of life and accepting the newness of Life in and of Spirit as a gift of grace, bestowed on man through unity with Life
Truth	c. 1000 – 2000 A.D.	pioneering scientific consciousness, forcing the fall of mortal consciousness; grounding our understanding of true being and manhood in scientific methods rather than relying on blind faith
Love	c. 2000 A.D. onwards	the reign of divine Science: annihilation of fear, anxiety, provincialism, partiality, narrow-minded materialism; emergence of peace and fulfillment of the design of the Bible to establish a divinely scientific consciousness of God.

Du Noüy

The Seven Stages of Evolution

There are seven undeniable fundamental facts that cannot be explained by natural science, yet form the backbone of evolution. These are as follows:

- | | | |
|---|--|-----------|
| 1. “The beginning of life” | First Cause, creative ability, divine Will, Intelligence | MIND |
| 2. “The evolution of life toward more and more complex forms” | Evolution, irreversible progress, diversification | SPIRIT |
| 3. “The actual result of this long process, namely, man and the human brain” | Freedom, incorporeality, identity | SOUL |
| 4. “The birth of thought, and of moral and spiritual ideas” | Relation to God, obedience, government, ideas, harmony, coordination (system), spiritual power | PRINCIPLE |
| 5. “The spontaneous and independent development of these ideas in different parts of the terrestrial globe” | Spontaneity, simultaneity, instantaneity, individuality | LIFE |
| 6. The “transformation of man into an active, responsible individual” | Ideal, dominion, victory, human dignity | TRUTH |
| 7. The existence of a telefinalistic plan | Telefinalistic plan, fulfillment | LOVE |

From Max Kappeler, *A Recent Theory of Evolution and Its Implications*

The numerals of infinity, called seven days
(S&H 520:10)

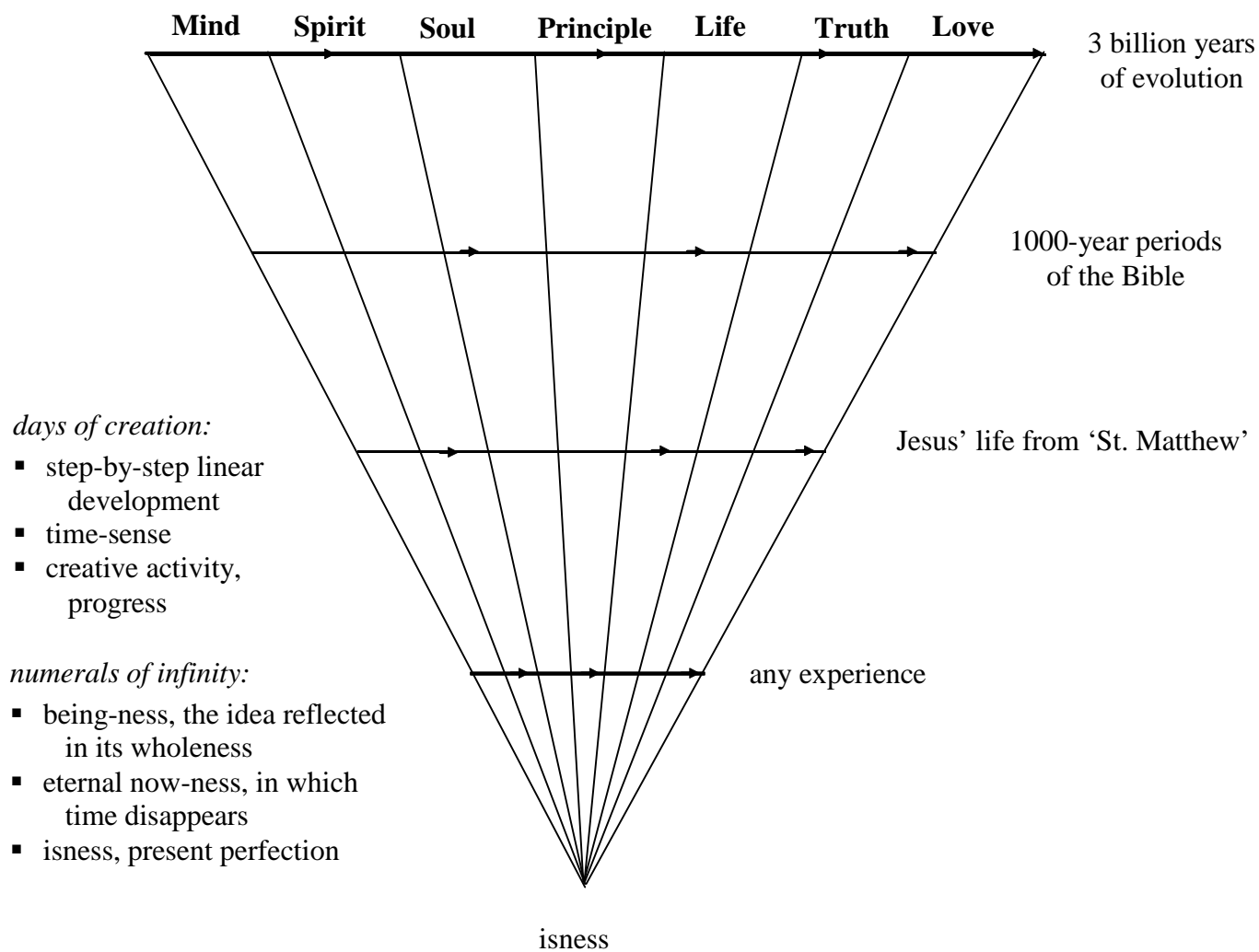

References:

Books by Max Kappeler:

Compendium for the Study of Christian Science, No. 2: The Seven Days of Creation, pp. 33–35.
The Seven Synonyms for God, chapter 2: the order of the seven days, also chapter 6: the Word-order.

Recordings by Max Kappeler:

- A-6III: *Syllabus III*, 1978, Wilmington, DE, hours 8–10, 26–27.
- B-2: *From Atomistic Thinking to Cybernetic Comprehensive Consciousness*, 1970, Ogunquit, ME, hours 2–5.
- C-1G: *Ch. XV, "Genesis", The Structure of the Christian Science Textbook—Our Way of Life*, 1981, hours 13B–14A.
- G-2: *The Science of Being—as I see it today*, Max Kappeler, 1970, London, England, hours 2B–3.
- M-33: *The Days of Creation become the Numerals of Infinity*, (4 hours from B-2, #s 2–5).

Books by John Doorly:

God and Science—Symbols and their importance, Publisher: London, F. Muller [©1949], statement pp. 15–16, 41–48, Appendix I, pp. 216–218.
The Pure Science of Christian Science, pp. 18–19, 47–48.
Talks on the Science of the Bible, Vol. I "red-book," pp. 59–61, 63–65, 80–83, 155–157, 259–260, 272–274.
Talks on the Science of the Bible, Vol. II "red-book," pp. 54–55.
Talks at the Oxford Summer School, 1948, Vol. I, p. 20.
Talks at the Oxford Summer School, 1949, Vol. II, pp. 136–137, 145–146, 148–151, 156–157.

From Atomistic Thinking to Cybernetic Comprehensive Consciousness – Audio Code B-2

© 1970, 2005 Kappeler Institute for the Science of Being, PO Box 99735, Seattle, WA 98139-0735. All rights reserved.

Days of Creation—Numerals of Infinity
(S&H 520:10)

Synonym	Day of Creation	Numeral of Infinity
Mind	beginning creator guides, leads wisdom	all, idea power law intelligence, knowing
Spirit	separation development birth purity	reality order substance understanding
Soul	resurrection reforms from sense to Soul balance	identity rule safety joy, freedom
Principle	interprets teaches proves practice	Science system foundational absolute
Life	exaltation aspiration inspiration love	immortality individuality ever-presence eternity
Truth	affirmative dominion health alternative	divine consciousness ideal form Christ
Love	rest fulfillment protects disposes	glory perfection ascension design

References for the Days of Creation—Numerals of Infinity (S&H 520:10)

Books by Max Kappeler:

Compendium for the Study of Christian Science, No. 2: The Seven Days of Creation, pp. 33–35.
The Seven Synonyms for God, chapter 2: the order of the seven days, also chapter 6: the Word-order.

Recordings by Max Kappeler:

- A-6III: *Syllabus III*, 1978, Wilmington, DE, hours 26–27.
B-2: *From Atomistic Thinking to Cybernetic Comprehensive Consciousness*, 1970, Ogunquit, ME, hours 2–5.
C-1G: *Ch. XV, “Genesis”, The Structure of the Christian Science Textbook—Our Way of Life*, 1981, hours 13B–14A.
M-33: *The Days of Creation become the Numerals of Infinity*, (4 hours from B-2, #s 2–5).

Books by John Doorly:

God and Science—Symbols and their importance, Publisher: London, F. Muller [©1949], statement pp. 15–16, 41–48, Appendix I, pp. 216–218.
The Pure Science of Christian Science, pp. 18–19, 47–48.
Talks on the Science of the Bible, Vol. I “red-book,” pp. 59–61, 63–65, 80–83, 155–157, 272–274.
Talks on the Science of the Bible, Vol. II “red-book,” pp. 54–55.
Talks at the Oxford Summer School, 1948, Vol. I, p. 20.
Talks at the Oxford Summer School, 1949, Vol. II, pp. 136–137, 145–146, 148–151, 156–157.

Subtones of the Days of Creation

Day	Biblical topic TONE	Biblical Subtopic	Subtone
1	Light MIND	1) There was light 2) Light was good, divided from darkness 3) Light was called Day	Mind Spirit Soul
2	Firmament SPIRIT	1) Let there be a firmament to divide 2) Firmament divided the waters 3) The firmament is called Heaven	Mind Spirit Soul
3	Earth bringing forth; Seed in itself SOUL	1) Water gathered together; dry land appears 2) Earth named and sea named 3) Let the earth bring forth grass, herb, etc. 4) Brought forth after its kind 5) Third day: resurrection	Mind Spirit Soul Principle Life
4	Sun, moon, stars PRINCIPLE	1) Lights for signs, seasons, days, years 2) Give light upon the earth 3) Greater light ruling the lesser 4) Ruling over day and night 5) "Marking periods of progress"	Mind Spirit Soul Principle Life
5	Fish and fowl LIFE	1) Waters bring forth abundantly the moving creature that has life and fowl that fly above the earth 2) Waters brought forth every living creature and every winged fowl 3) Blessed them: be fruitful, multiply, fill the earth 4) "Exalted beings"	Mind Spirit Soul Principle
6	Animals and man TRUTH	1) Earth brings forth living creature, cattle, creeping thing, beast of the earth 2) It was good 3) Let us make man in our image after our likeness 4) Male and female created he them 5) Be fruitful, multiply, and replenish the earth 6) Man is given herb, tree; beast is given green herb 7) Everything very good	Mind Spirit Soul Principle Life Truth Love
7	Creation finished LOVE	6) Heavens, earth, all the host of them finished 7) Work ended, rest from work	Truth Love

Subtones of the Days of Creation (Genesis 1:3–2:2)

	1 st Day	2 nd Day	3 rd Day	4 th Day	5 th Day	6 th Day	7 th Day
MIND	Mind/Mind 1:3	Spirit/Mind 1:6	Soul/Mind 1:9	Principle/Mind 1:14	Life/Mind 1:20	Truth/Mind 1:24	
SPIRIT	Mind/Spirit 1:4	Spirit/Spirit 1:7	Soul/Spirit 1:10	Principle/Spirit 1:15	Life/Spirit 1:21	Truth/Spirit 1:25	
SOUL	Mind/Soul 1:5	Spirit/Soul 1:8	Soul/Soul 1:11	Principle/Soul 1:16	Life/Soul 1:22	Truth/Soul 1:26	
PRINCIPLE			Soul/ Principle 1:12	Principle/ Principle 1:17–18	Life/ Principle 1:23	Truth/ Principle 1:27	
LIFE			Soul/Life 1:13	Principle/Life 1:19		Truth/Life 1:28	
TRUTH						Truth/Truth 1:29-30	Love/Truth 2:1
LOVE						Truth/Love 1:31	Love/Love 2:2

The Day of Life, Truth, Love
(The Seven Days of Creation)
 (Gen. 1:3–2:2)

Day of Creation	Life: The Creative	Truth: The Factual	Love: The Fulfilled
1 st Day	Let there be light (1:3)	And God divided the light from the darkness (1:4)	And God called the light Day (1:5)
2 nd Day	Let there be a firmament (1:6)	And God made the firmament (1:7)	And God called the firmament Heaven (1:8)
3 rd Day	Let the dry land appear (1:9, 10)	Let the earth bring forth grass, and herb yielding seed, and the fruit tree yielding fruit after his kind, whose seed is in itself (1:11)	And the earth brought forth grass, and herb, and the tree yielding fruit (1:12, 13)
4 th Day	Let there be lights...for signs and for seasons and for days, and years...to give light on the earth (1:14, 15)	God made two great lights...to rule the day and the night (1:16)	God set them in the firmament of the heaven...to rule (1:17–19)
5 th Day	Let the waters bring forth abundantly the moving creature that hath life (1:20)	God created great whales, and every living creature that moveth...and every winged fowl (1:21)	God said, be fruitful and multiply (1:22, 23)
6 th Day	Let the earth bring forth the living creature (1:24, 25)	Let us make man in our image, after our likeness. God created man in His own image (1:26, 27)	Be fruitful, and multiply...and have dominion (1:28–31)
7 th Day (as Truth) (as Love)	Heavens... (2:1) On the seventh day God ended... (2:2)	And earth... (2:1) ...His work which He had made... (2:2)	and all the hosts of them were finished (2:1) ...And he rested... from all His work (2:2)

References:

Recordings by Max Kappeler:

- C-1G: *Ch. XV, "Genesis", The Structure of the Christian Science Textbook—Our Way of Life*, 1981, hours 10B, 15.
 D-4: *Divine Cybernetics and the Self-operating "Dimensional Laws" of the One Being, God: Word (Part I), Word* 1971/72 – New York, hours 11–12.

Books by John Doorly:

- Talks at the Oxford Summer School 1949, Vol. I*, pages 7–48.

From Atomistic Thinking to Cybernetic Comprehensive Consciousness – Audio Code B-2

© 1970, 2005 Kappeler Institute for the Science of Being, PO Box 99735, Seattle, WA 98139-0735. All rights reserved.

Perfect Ideas – 1

IDEA	MIND	SPIRIT	SOUL
Intelligence	Creative	Ordered	Definite
Substance			
Joy			
Harmony			
Abundance			
Health			
Fulfillment			

Prism and Lens: Its Spiritually Scientific Development

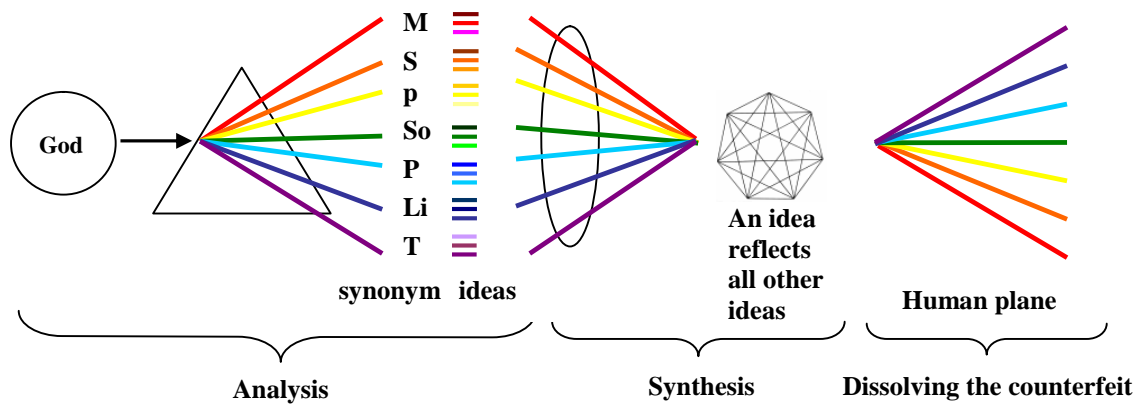
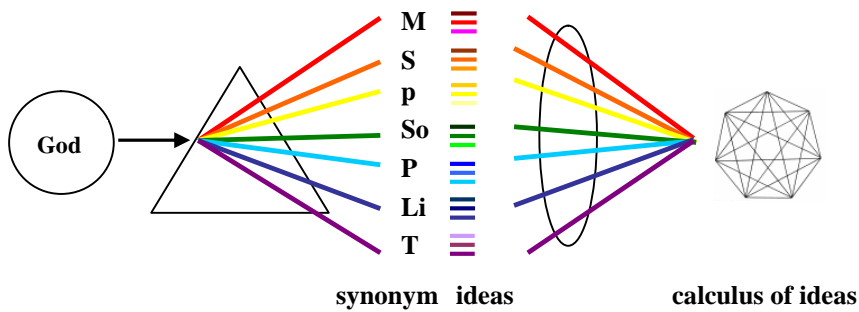
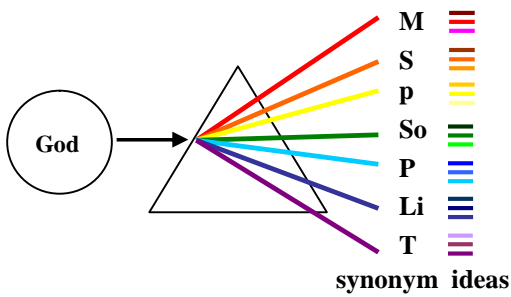
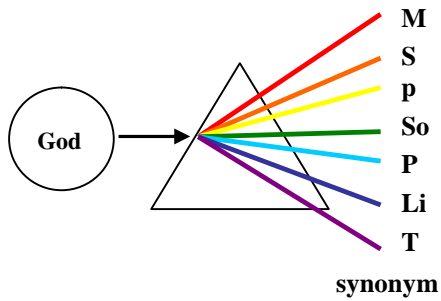

Prism and Lens: An Explanation of Mary Baker Eddy's Statements

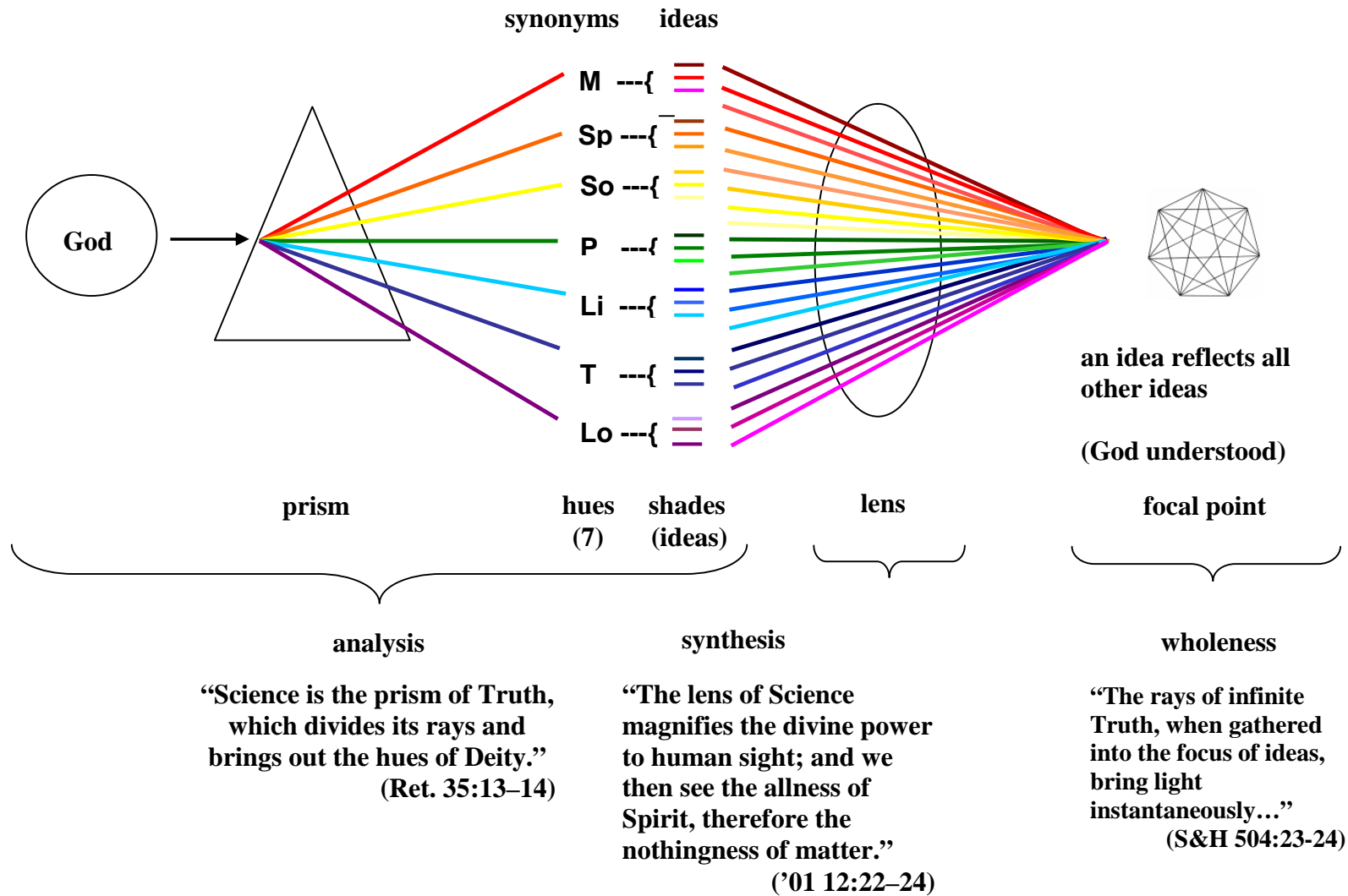

References for “Prism and Lens”:

Books by Max Kappeler:

Introduction to the Science of Christian Science.

The Bible in the Light of Christian Science, Vol. I: Genesis, p. 93.

Recordings by Max Kappeler:

A-1: *An Introduction to the Science of Christian Science*, 1962, Zürich, Switzerland, hour 3A.

A-4: *The Structure-principle of Being*, 1974, Wilmington, DE, hours 4–6.

B-2: *From Atomistic Thinking to Cybernetic Comprehensive Consciousness*, 1970, Ogunquit, ME, hours 4–5.

D-4: *Divine Cybernetics and the Self-operating “Dimensional Laws” of the One Being, God: Word (Part I), Word (Part II), The Christ (Part III), Christianity (Part IV)*, 1971/72, New York, hour 2.

G-2: *The Science of Being—as I see it today*, Max Kappeler, 1970, London, England, hour 3.



**The Seven Root Errors are Counterfeits of
Mind, Spirit, Soul, Principle, Life, Truth, Love**

Original fact		Counterfeit: simulation
Mind one Mind	exact opposite	many minds
Spirit Mind – substance (idea – substance)	exact opposite	mind and matter substance
Soul Mind – identity	exact opposite	mind and matter identity
Principle Mind’s laws govern	exact opposite	personal opinions govern
Life Mind, as Life is eternal	exact opposite	mind, as life, dies
Truth Mind, as Truth, is divine consciousness	exact opposite	mind, as truth, is human consciousness
Love Mind, as Love, is perfect	exact opposite	mind, as love, is imperfect

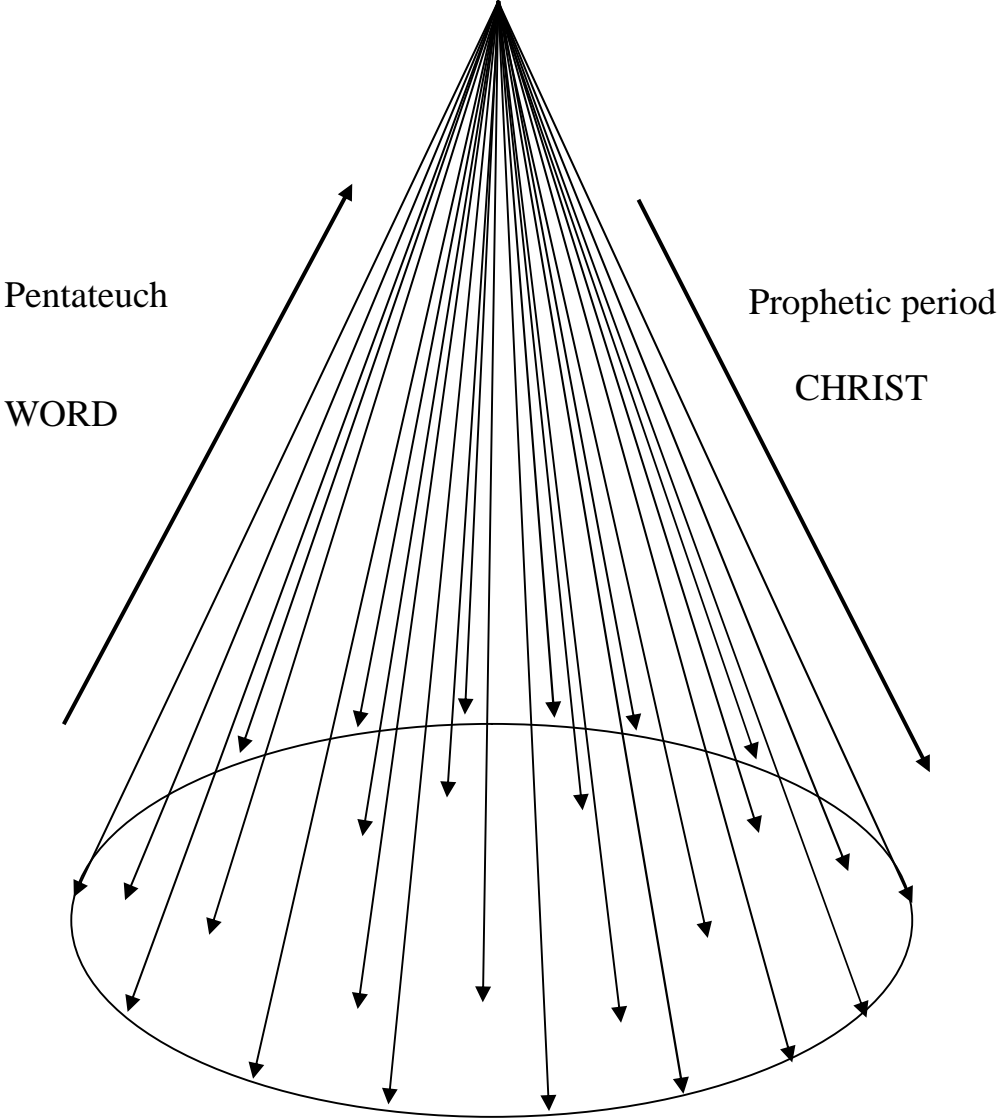
**Christ Translation—
coming down to all points**



Razor Blade

- 1) _____ to the eye
- 2)  to a microscope
- 3) □□□□□□□□□□ to chemistry
- 4) 

The Holy City

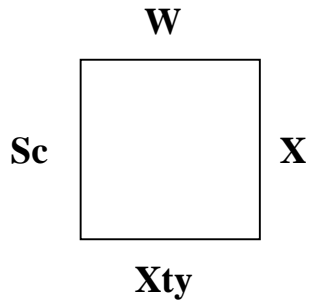

WORD	CHRIST	CHRISTIANITY	SCIENCE
incorporeal	divine	supreme	infinite
seeking	finding	using	being
addition	subtraction	multiplication	division
revelation	translation	reflection	interpretation
Law	Prophets	Jesus Christ	Science and Health
Matthew	Mark	Luke	John
omnipotence	omniscience	omnipresence	omniaction
line	plane	space	fourth dimension
Journal	Sentinel	Herald	Monitor
north	east	south	west

W

p. 465

X

p. 115

Xty

p. 587

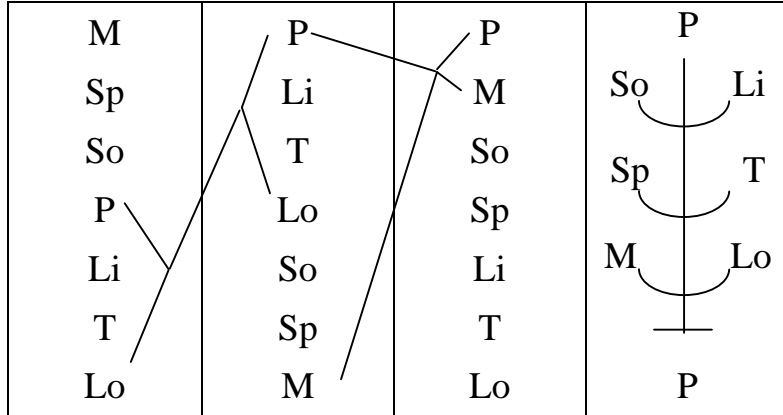
S

	M	Sp	So	P	Li	T	Lo
M	M/M	Sp/M	So/M	P/M			
Sp	M/Sp	Sp/Sp	So/Sp				
So	M/So	Sp/So					
P	M/P	Sp/P					
Li	M/Li						
T	M/T						
Lo	M/Lo						

Each Side Reflects All Other Sides

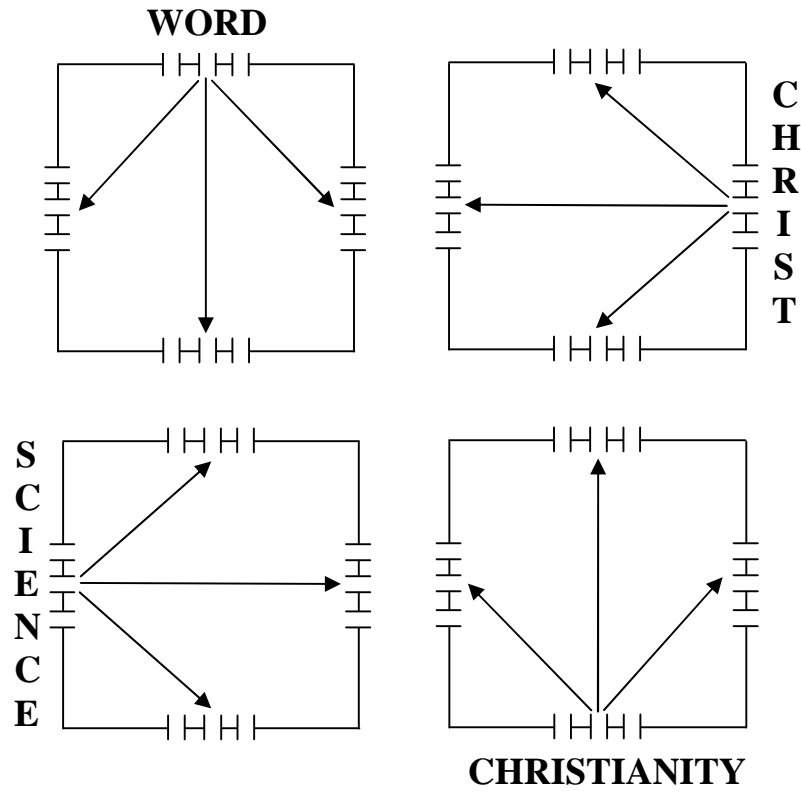

Matrix of the Four

	W	X	<u>Xty</u>	Sc
W	W/W	X/W	Xty/W	Sc/W
X	W/X	X/X	Xty/X	Sc/X
Xty	W/Xty	X/Xty	Xty/Xty	Sc/Xty
Sc	W/Sc	X/Sc	Xty/Sc	Sc/Sc

Layout of the Platform

(in Science and Health with Key to the Scriptures, by Mary Baker Eddy, pp. 330–340)

Word (W): 8 questions = 4 statements, 2 aspects each	↗ ↘	absolute C.S. Christian Science
Christ (X): 8 questions = 4 statements, 2 aspects each	↗ ↘	absolute C.S. Christian Science
Christianity (Xty): 8 questions = 4 statements, 2 aspects each	↗ ↘	absolute C.S. Christian Science
Science (Sc): 8 questions = 4 statements, 2 aspects each	↗ ↘	absolute C.S. Christian Science

	1–8 Creator WORD	9–16 Translation CHRIST	17–24 Reflection CHRISTIANITY	25–32 Understanding SCIENCE
W				
X				
Xty				
Sc				

Word-matrix

Science-matrix

Science & Health

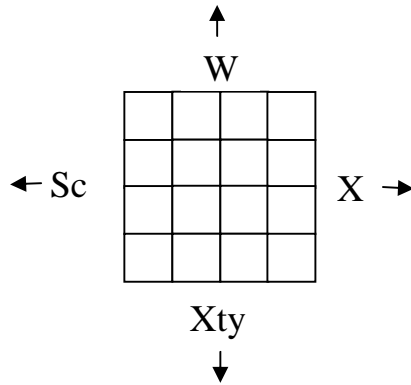

Christ-matrix

Prophets

Christianity-matrix

Epistles

Science-order

Word-order (S&H 465): ordered sequence

Mind → Spirit → Soul → Principle → Life → Truth → Love

Science-order: order becomes structure (candlestick)

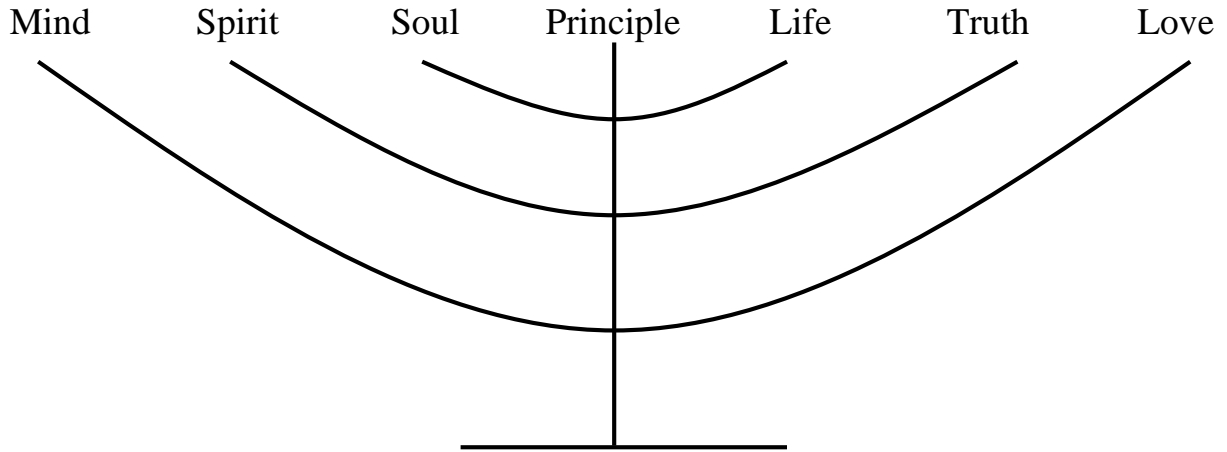

Science-order reveals structure

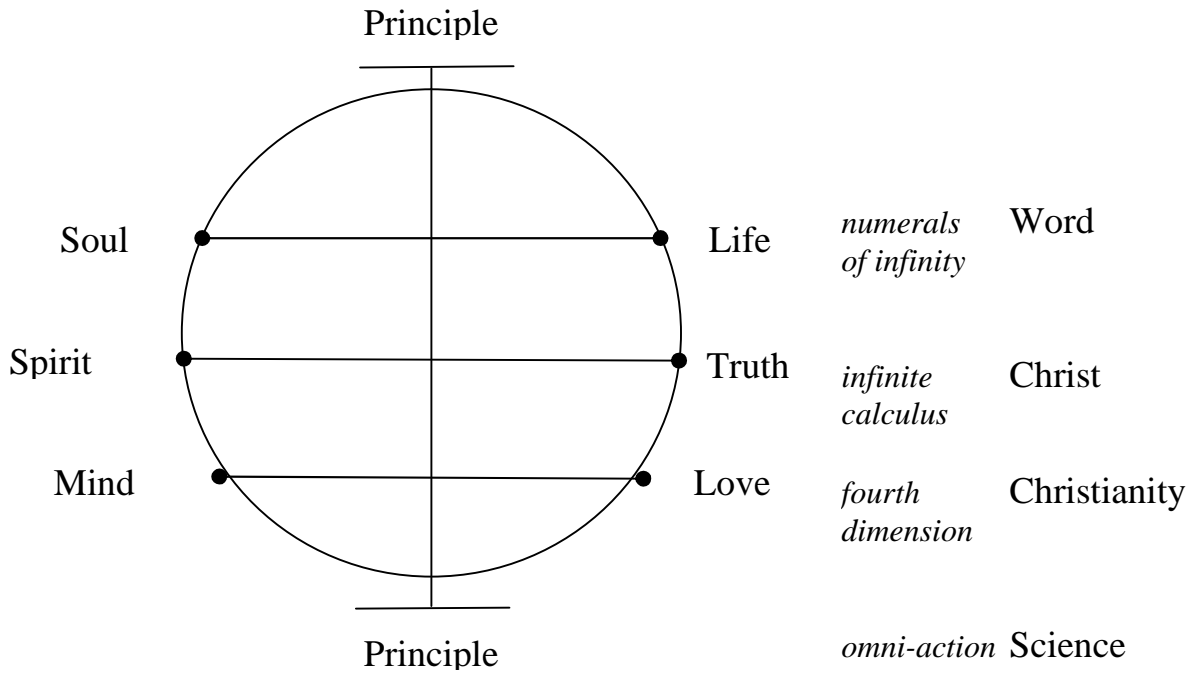

John Doorly's Matrix
as it was left to us by John W. Doorly (1950)

	WORD	CHRIST	CHRISTIANITY	SCIENCE
WORD	Order MIND SPIRIT SOUL	Manifestation PRINCIPLE LIFE TRUTH LOVE	Reflection PRINCIPLE MIND SOUL SPIRIT	Numerals of Infinity PRINCIPLE SOUL ——— LIFE
CHRIST	Identity SOUL PRINCIPLE LIFE	Translation TRUTH LOVE SOUL SPIRIT	Reality SPIRIT LIFE TRUTH	Infinite Calculus SPIRIT ——— TRUTH
CHRISTIANITY	Line LIFE TRUTH	Plane LOVE SOUL SPIRIT MIND	Space MIND SOUL SPIRIT LIFE TRUTH LOVE	Fourth Dimension MIND ——— LOVE
SCIENCE	Omnipotence LIFE TRUTH LOVE	Omniscience SOUL SPIRIT MIND	Omnipresence LIFE TRUTH LOVE	Omni-action PRINCIPLE

From John W. Doorly, *The Pure Science of Christian Science* (London: The Foundational Book Company for the John W. Doorly Trust, 1949).

John Doorly's Matrix (Word-matrix)

	WORD <i>(God's self-declaration)</i>	CHRIST <i>(the Christ-idea)</i>	CHRISTIANITY <i>(God's infinite self-reflection)</i>	SCIENCE <i>(God's self-interpretation as Science)</i>
WORD <i>(creative)</i>	<i>order</i> MIND SPIRIT SOUL	<i>manifestation</i> PRINCIPLE LIFE TRUTH LOVE	<i>reflection</i> PRINCIPLE MIND SOUL SPIRIT	<i>numerals of infinity</i> PRINCIPLE SOUL ——— LIFE
CHRIST <i>(Christ-selfhood)</i>	<i>identity</i> SOUL PRINCIPLE LIFE	<i>translation</i> TRUTH LOVE SOUL SPIRIT	<i>reality</i> SPIRIT LIFE TRUTH	<i>infinite calculus</i> SPIRIT ——— TRUTH
CHRISTIANITY <i>(Pure demonstration)</i>	<i>line</i> LIFE TRUTH	<i>plane</i> LOVE SOUL SPIRIT MIND	<i>space</i> MIND SOUL SPIRIT LIFE TRUTH LOVE	<i>fourth dimension</i> MIND ——— LOVE
SCIENCE <i>(God-being)</i>	<i>omnipotence</i> LIFE TRUTH LOVE	<i>omniscience</i> SOUL SPIRIT MIND	<i>omnipresence</i> LIFE TRUTH LOVE	<i>omni-action</i> PRINCIPLE

References: Books by John W. Doorly:

The Pure Science of Christian Science (London: The Foundational Book Company for the John W. Doorly Trust, 1949), 2nd edition, p. 53.

Christian Science Practice (London: The Foundational Book Company for the John W. Doorly Trust, 1949), p. 358.

From Atomistic Thinking to Cybernetic Comprehensive Consciousness – Audio Code B-2

© 1970, 2005 Kappeler Institute for the Science of Being, PO Box 99735, Seattle, WA 98139-0735. All rights reserved.

The Christ-matrix

	WORD <i>The mono-potency of God, good</i>	CHRIST <i>The manifestation of the Christ-likeness</i>	CHRISTIANITY <i>The preservation of the idea</i>	SCIENCE <i>The operation of the idea in its Principle</i>
Word <i>the divine purpose defined</i>	Hosea	Obadiah	Nahum	Haggai
Christ <i>the enforcement of the translation of two-ness into oneness</i>	Joel	Jonah	Habakkuk	Zechariah
Christianity <i>the disappearance of evil and the appearance of good rendered inescapable</i>	Amos	Micah	Zephaniah	Malachi
Science <i>the understanding of God</i>	Isaiah	Jeremiah	Ezekiel	Daniel

References:

Books by Max Kappeler:

The Minor Prophets in the Light of Christian Science (the entire book is devoted to this subject).

Recordings by Max Kappeler:

B-2: *From Atomistic Thinking to Cybernetic Comprehensive Consciousness*, 1970, Ogunquit, ME, hours 11B–12.

E-2: *The Matrix of Immortality: Code of divine laws*, 1974, Wilmington, DE, hours 16–22A.

F-1: *The Minor Prophets in the Light of Christian Science*, 1962, Los Angeles, CA, 32 hours.

G-2: *The Science of Being—as I see it today*, 1970, London, England, hours 6–7.

From Atomistic Thinking to Cybernetic Comprehensive Consciousness – Audio Code B-2

© 1970, 2005 Kappeler Institute for the Science of Being, PO Box 99735, Seattle, WA 98139-0735. All rights reserved.

The Christianity-matrix
 = *the reciprocal relation of man to:*

	WORD <i>the grace of God</i>	CHRIST <i>the glory of Christ</i>	CHRISTIANITY <i>the idea of man's perfection</i>	SCIENCE <i>the Science of man</i>
Word <i>accepting the new faith</i>	Romans	Galatians	Colossians	Pastoral Epistles (I Timothy) (II Timothy) (Titus)
Christ <i>claiming the new faith</i>	I Corinthians	Ephesians	I Thessalonians	Philemon
Christianity <i>steadfastly abiding in the new faith</i>	II Corinthians	Philippians	II Thessalonians	Hebrews
Science <i>proving the new faith by living it</i>	James	I & II Peter	I, II, III John	Jude

References:

Books by Max Kappeler:

The Epistles in the Light of Christian Science (the entire book is devoted to this subject).

Recordings by Max Kappeler:

B-2: *From Atomistic Thinking to Cybernetic Comprehensive Consciousness*, 1970, Ogunquit, ME, hours 12B–13A.

E-2: *The Matrix of Immortality: Code of divine laws*, 1974, Wilmington, DE, hours 22–23.

F-2: *The Epistles in the Light of Christian Science*, 1962, Los Angeles, CA, 31 hours.

G-2: *The Science of Being— as I see it today*, 1970, London, England, hours 6–7.

From Atomistic Thinking to Cybernetic Comprehensive Consciousness – Audio Code B-2

© 1970, 2005 Kappeler Institute for the Science of Being, PO Box 99735, Seattle, WA 98139-0735. All rights reserved.

The Matrix of Christian Science

(in *Science and Health with Key to the Scriptures*, by Mary Baker Eddy, Chapters I–XVI)

absolute standpoint (j) relative standpoint (i)	WORD revelation of God's nature	CHRIST translation of God to idea	CHRISTIANITY the realm of ideas	SCIENCE Principle and idea is one
Word accepting the proposition	CHAPTER I <i>Prayer</i> revelation of God's nature by accepting God's nature in us	CHAPTER V <i>Animal Magnetism Unmasked</i> As we accept the Christ- translation, the ungodlike is translated back into its native nothingness	CHAPTER IX <i>Creation</i> As we accept the realm of ideas, the ideational universe reveals itself to us	CHAPTER XIII <i>Teaching Christian Science</i> By accepting our oneness with Principle, we are Principle- idea
Christ power of manifestation in spite of error	CHAPTER II <i>Atonement and Eucharist</i> God's nature manifests itself in us in spite of the ungodlike in us	CHAPTER VI <i>Science, Theology, Medicine</i> The Christ-translation manifests itself by translating the false constituents into the true constituents of Being	CHAPTER X <i>Science of Being</i> The dynamic power of manifestation of ideas dissolves both latent and concrete error	CHAPTER XIV <i>Recapitulation</i> Principle-idea manifests itself as a calculus of ideas and corrects the calculus of human beliefs
Christianity exalted being	CHAPTER III <i>Marriage</i> God's nature demonstrates itself in us as a higher humanhood	CHAPTER VII <i>Physiology</i> The Christ-translation translates mortals into immortals	CHAPTER XI <i>Some Objections Answered</i> The perfect reflection of ideas exalts a theoretical Christianity to a practical Christianity	CHAPTER XV <i>Genesis</i> In the oneness of Principle and idea, creation is exalted in its divine Principle
Science scientific understanding	CHAPTER IV <i>Christian Science vs. Spiritualism</i> God's nature can be understood only by scientific methods of understanding	CHAPTER VIII <i>Footsteps of Truth</i> The Christ-translation translates an unscientific consciousness into a scientific consciousness	CHAPTER XII <i>Christian Science Practice</i> A scientific understanding of ideas heals	CHAPTER XVI <i>The Apocalypse</i> Scientific understanding recognizes that on all levels of existence, only the idea of Principle is ever going on

From *Atomistic Thinking to Cybernetic Comprehensive Consciousness – Audio Code B-2*

© 1970, 2005 Kappeler Institute for the Science of Being, PO Box 99735, Seattle, WA 98139-0735. All rights reserved.

References for “The Matrix of Christian Science”

Books by Max Kappeler:

The Development of the Christian Science Idea and Practice ©2004, 2nd edition, pp. 8–18 (the development of the Science and structure of the textbook).

Epitomes for the Spiritually Structured Interpretation of the Christian Science Textbook (the entire book is presents an elaboration of this subject).

The Science of the Oneness of Being in the Christian Science Textbook, Appendix, Table 3, also pp. 263–267.

The Structure of the Christian Science Textbook (the entire book is devoted to explaining this subject).

‘*Stately Science Pauses Not*,’ booklet, pp. 31–47.

When I think of John W. Doorly...II—Introduction to the Matrix Consciousness, ©2002.

Recordings by Max Kappeler:

B-2: *From Atomistic Thinking to Cybernetic Comprehensive Consciousness*, 1970, Ogunquit, ME, hours 13–14.

C-1: *The Structure of the Christian Science Textbook, our way of Life*, an extensive series of talks spanning the last 30 years of Series talks on the Textbook’s structure, covering both the structure of each chapter and the structure of the textbook as a whole. (see the Kappeler Institute Writings and Recordings Catalog or visit the Kappeler Institute website at www.kappelerinstitute.org)

C-2: *The Christian Science Textbook — a workshop on text-interpretation*, an analysis of the structure of the first five chapters to illustrate Series the structural and scientific method of text-interpretation. (see the Kappeler Institute Writings and Recordings Catalog or visit the Kappeler Institute website at www.kappelerinstitute.org)

C-4: *The Matrix of “Science and Health”: An overview*, 1975, Wilmington, DE, hours 7–24.

C-6: *Exercises in Culturing Consciousness According to the Matrix of “Science and Health,”* 1976, Ilkley, England, 26 hours, especially hours 2B–9A.

E-2: *The Matrix of Immortality: Code of divine laws*, 1974, Wilmington, DE, hours 11–16A.

M-20: *The Structure of the Christian Science Textbook: An Overview*, 2 hours.

The translation of “St. Matthew” into Science

<i>Biblical symbols</i>	<i>metaphysics</i>	<i>Science</i>
1) genealogy	parent Mind	Mind
2) baptisms	purification	Spirit
3) temptations	identity	Soul
4) Sermon on the Mount	interpretation	Principle
5) healings	fullness of life	Life
6) What is man?	calculus of ideas	Truth
7) resurrection	fulfillment	Love
	} specific } linear } interpretation	} general } structural } creative

The formulation of phenomena into a scientific law

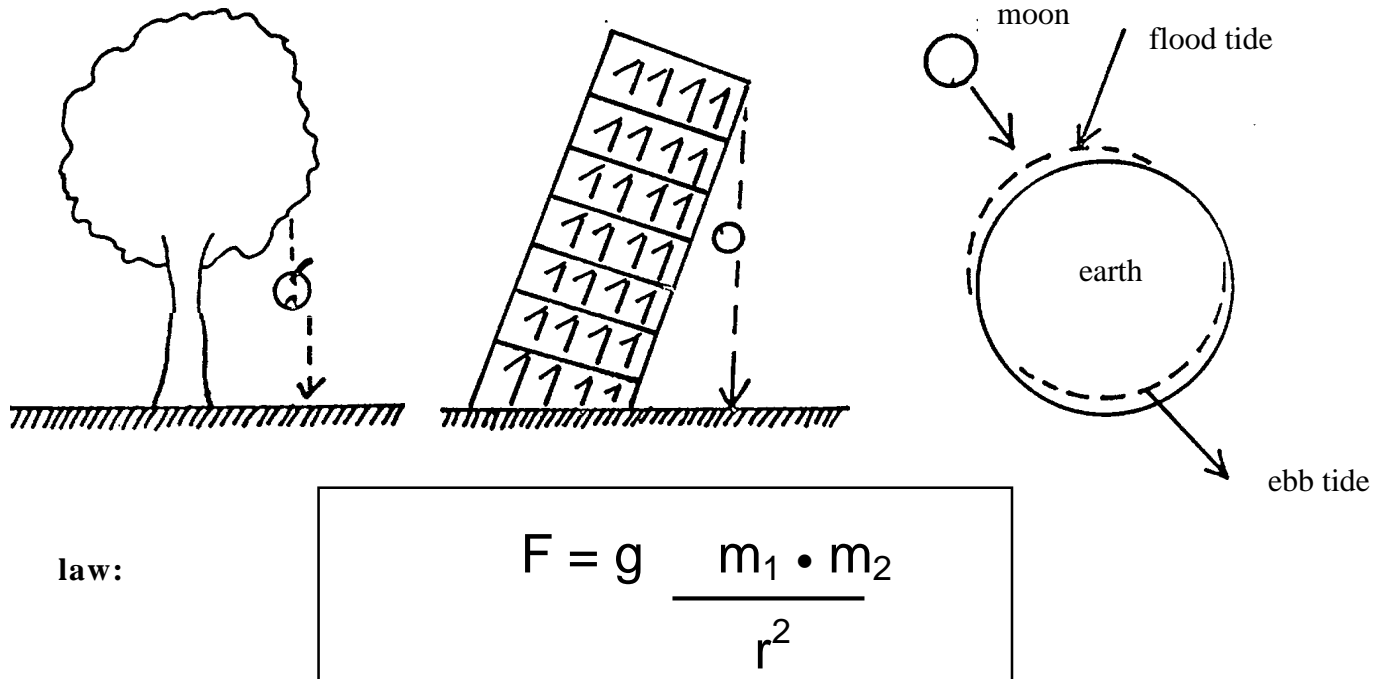

law:

References:

Recordings by Max Kappeler:

B-2: *From Atomistic Thinking to Cybernetic Comprehensive Consciousness*, 1970, Ogunquit, ME, hour 16.

D-4: *Divine Cybernetics and the Self-operating “Dimensional Laws” of the One Being, God*, 1971/72, New York, hour 12B.

E-1: *The Structure of Being and its Universal Laws*, 1973, New York, hour 29B.

G-2: *The Science of Being—as I see it today*, 1970, London, England, #7.

From Atomistic Thinking to Cybernetic Comprehensive Consciousness – Audio Code B-2

© 1970, 2005 Kappeler Institute for the Science of Being, PO Box 99735, Seattle, WA 98139-0735. All rights reserved.

Mind Matrix

(in *Science and Health with Key to the Scriptures*, by Mary Baker Eddy, Chapters I–XVI)

Mind	WORD all-Mind	CHRIST all-power of Mind	CHRISTIANITY allness of ideas	SCIENCE Mind and Mind-idea is one
Word Accepting the proposition	<i>I. Prayer</i> Mind is all-knowing	<i>V. Animal Magnetism Unmasked</i> Only the power of Mind operates, working out only good	<i>IX. Creation</i> Mind is the creator of all as idea	<i>XIII. Teaching Christian Science</i> The mind of the student must be in unity with the divine Mind
Christ the power of manifestation in spite of error	<i>II. Atonement and Eucharist</i> the power of Mind over material intelligence and matter	<i>VI. Science, Theology, Medicine</i> The all-power of Mind, not matter, is the all-redeeming power	<i>X. Science of Being</i> All is Mind and its infinite manifestation	<i>XIV. Recapitulation</i> All that is going on is Mind and Mind-idea
Christianity exalted being	<i>III. Marriage</i> Mind is superior to the human mind and matter	<i>VII. Physiology</i> To Mind and with Mind all is possible; Mind governs and controls all	<i>XI. Some Objections Answered</i> Before the unlimited divine Mind, all limited views must yield	<i>XV. Genesis</i> Mind constantly reveals itself as an ordered unfoldment of ideas
Science scientific understanding	<i>IV. Christian Science vs. Spiritualism</i> Mind alone possesses the faculty of knowing	<i>VIII. Footsteps of Truth</i> The understanding that there is only one Mind makes all harmonious and perfect	<i>XII. Christian Science Practice</i> The understanding that all is Mind heals	<i>XVI. The Apocalypse</i> The understanding of Mind uncovers the illusions of mortal mind

References:

Recordings by Max Kappeler:

B-2: *From Atomistic Thinking to Cybernetic Comprehensive Consciousness*, 1970, Ogunquit, ME, hours 14B–15.

G-2: *The Science of Being—as I see it today*, 1970, London, England, hour 5.

Books by Max Kappeler:

The Seven Synonyms for God, Chapter 9, which also includes the matrices for the other synonyms. *Compendium for the Study of Christian Science, No. 7: Principle*, Appendix I, pp. 212–214, presents the tone of Principle in each chapter.

From Atomistic Thinking to Cybernetic Comprehensive Consciousness – Audio Code B-2

© 1970, 2005 Kappeler Institute for the Science of Being, PO Box 99735, Seattle, WA 98139-0735. All rights reserved.

The Matrix of Handling Evil

(in Science and Health with Key to the Scriptures, by Mary Baker Eddy, Chapters I–XVI)

	WORD <i>evil must be mastered</i>	CHRIST <i>the power of Truth destroys evil; evil has no power</i>	CHRISTIANITY <i>demonstrating the superiority of good over evil</i>	SCIENCE <i>by proving good, evil is disproved</i>
Word <i>Accepting the proposition</i>	I. Prayer the desire to be delivered from evil: deliver us from evil	V. Animal Magnetism Unmasked Science has the power to despoil evil, for evil is no power, action or law	IX. Creation Mortals must let themselves be used by good instead of by evil	XIII. Teaching Christian Science By resisting, exposing and denouncing evil, the nothingness of evil can be proved
Christ <i>the power of manifestation in spite of error</i>	II. Atonement and Eucharist the command to cast out evil	VI. Science, Theology, Medicine The power of Truth casts out evil	X. Science of Being The somethingness of good demonstrates the nothingness of evil	XIV. Recapitulation In the allness of God, good, evil has no place
Christianity <i>exalted being</i>	III. Marriage The good must have ascendancy over evil	VII. Physiology The only power of evil is to destroy itself	XI. Some Objections Answered denying that God either knows evil, made evil, or cooperates with evil	XV. Genesis Truth annihilates the belief in evil by reducing it to its nothingness
Science <i>scientific understanding</i>	IV. Christian Science vs. Spiritualism Understanding God, good, keeps evil in check	VIII. Footsteps of Truth Discernment of understanding good destroys the so-called power of evil	XII. Christian Science Practice Understanding the supremacy of good causes evil to disappear	XVI. The Apocalypse By understanding God, good, the nothingness of evil is made manifest

References to “The Matrix of Handling Evil”:

Recordings by Max Kappeler:

- A-6II: Syllabus II, 1977, hours 22–23.
- B-2: *From Atomistic Thinking to Cybernetic Comprehensive Consciousness*, 1970, Ogunquit, ME, hours 15B–16, 24.
- B-3 *Christian Science Practice: based on the Science of divine revelation*, 1976, Wilmington, DE, hours 3–8.
- C-1AN: CH. V, “Animal Magnetism Unmasked,” *The Structure of the Christian Science Textbook—Our Way of Life*, hours 2–4, 7B–8.
- C-6: *Exercises in Culturing Consciousness According to the Matrix of “Science and Health,”* 1976, Ilkley, England, hours 10–11.
- G-2: *The Science of Being—as I see it today*, 1970, London, England, hour 5.
- X-5 *The Problem of Handling Evil*, 6 cassettes from B-3 (hours 3–8).

Books by Max Kappeler:

Animal Magnetism — Unmasked, pp. 47–81.

Notes on Handling Evil, pamphlet.

Books by John Doorly:

Christian Science Practice, pp. 328–329, 344–346, 349–355.

Talks on the Science of the Bible, #70 “blue-book,” pp. 15–20.

Talks on the Science of the Bible, Vol. VI “red-book,” pp. 108–110, 231–232, 289–290.

Talks on the Science of the Bible, Vol. VII “red-book,” pp. 13–15, 16–19, 42, 83–85, 283–289.

From Atomistic Thinking to Cybernetic Comprehensive Consciousness – Audio Code B-2

© 1970, 2005 Kappeler Institute for the Science of Being, PO Box 99735, Seattle, WA 98139-0735. All rights reserved.

DIMENSIONALISM (against reductionism)

Diagram A

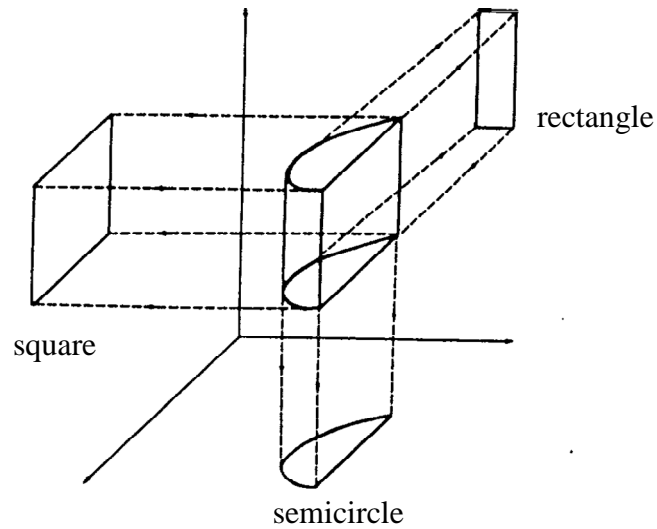

Diagram B

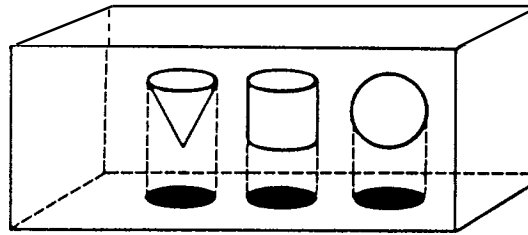
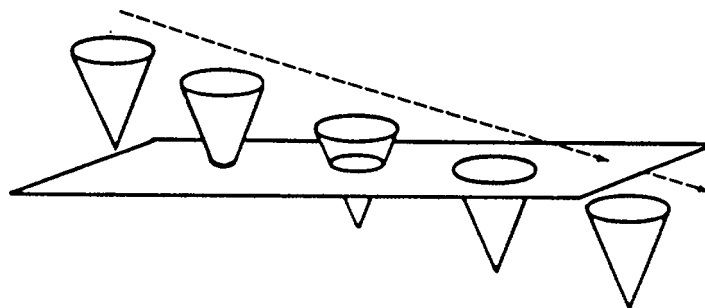

Diagram C



References:

Recordings by Max Kappeler:

- A-4: *The Structure-principle of Being*, 1974, Wilmington, DE, hour 20.
- A-6V: *Syllabus V*, 1980, hour 3.
- B-2: *From Atomistic Thinking to Cybernetic Comprehensive Consciousness*, 1970, Ogunquit, ME, hour 17.
- D-4: *Divine Cybernetics and the Self-operating "Dimensional Laws" of the One Being, God: Word (Part I), Word (Part II), The Christ (Part III), Christianity (Part IV)*, 1971/72, New York, hour 3.

- G-2: *The Science of Being—as I see it today*, Lecture, 1970, London, England, hours 6–7.

Books by Max Kappeler:

- The Seven Synonyms for God*, Chapter 7.
- The Science of the Oneness of Being in the Christian Science Textbook*, pp. 49–51.

Christian Science Practice

Practitioner				Patient
	Love and Mind <i>How he himself must be</i>	<i>Truth and Mind</i> <i>The Truth he knows</i>	<i>Life and Soul</i> <i>His Method</i>	Love Truth Life } <i>and Spirit</i> <i>Healing process</i>
Mind	seeing only perfection	Mind is all	law of Mind	<i>Love + Spirit</i> based on Mind-science
Spirit	good and pure	Spirit is the only reality	Spirit: the only substance	creates order
Soul	selfless	incorporeality and sinlessness of man	rule of Soul: supremacy;	<i>Truth + Spirit</i> translation takes place
Principle	winning his own pardon scientifically	Science and metaphysics: basis of demonstration	government: omnipotence of Principle	reaching every part of the system
Life	experiencing fullness of life; laying down the mortal concept	man maintained by fullness of Life	immortality: self-supporting Life	renewal of Life
Truth	growing into Christian manhood	man's dominion through consciousness	form of man: consciousness of Truth	<i>Life + Spirit</i> eternal life
Love	anticipating fulfillment	man's perfection; no penalty	fulfillment: perfection of Love	perfect health
				solution for every problem

References:

Books by Max Kappeler:

Epitomes for the Spiritually Structured Interpretation of the Christian Science Textbook, pp. 2–10.
The Science of the Oneness of Being in the Christian Science Textbook, pp. 183–196.
The Structure of the Christian Science Textbook, Vol. I.: Revelation of the Structure, pp. 116–135.

Books by John Doorly:

Christian Science Practice

Recordings by Max Kappeler:

A-4: *The Structure-principle of Being*, Wilmington, DE, hours 24–25.
 C-6: *Exercises in Structuring Consciousness According to the Matrix of "Science and Health,"* Ilkley, England, 26 hours
 C-1P: *CH. XII, "Christian Science Practice", The Structure of the Christian Science Textbook—Our Way of Life*, 17 hours.

From Atomistic Thinking to Cybernetic Comprehensive Consciousness – Audio Code B-2

© 1970, 2005 Kappeler Institute for the Science of Being, PO Box 99735, Seattle, WA 98139-0735. All rights reserved.

Divine Cybernetic Model

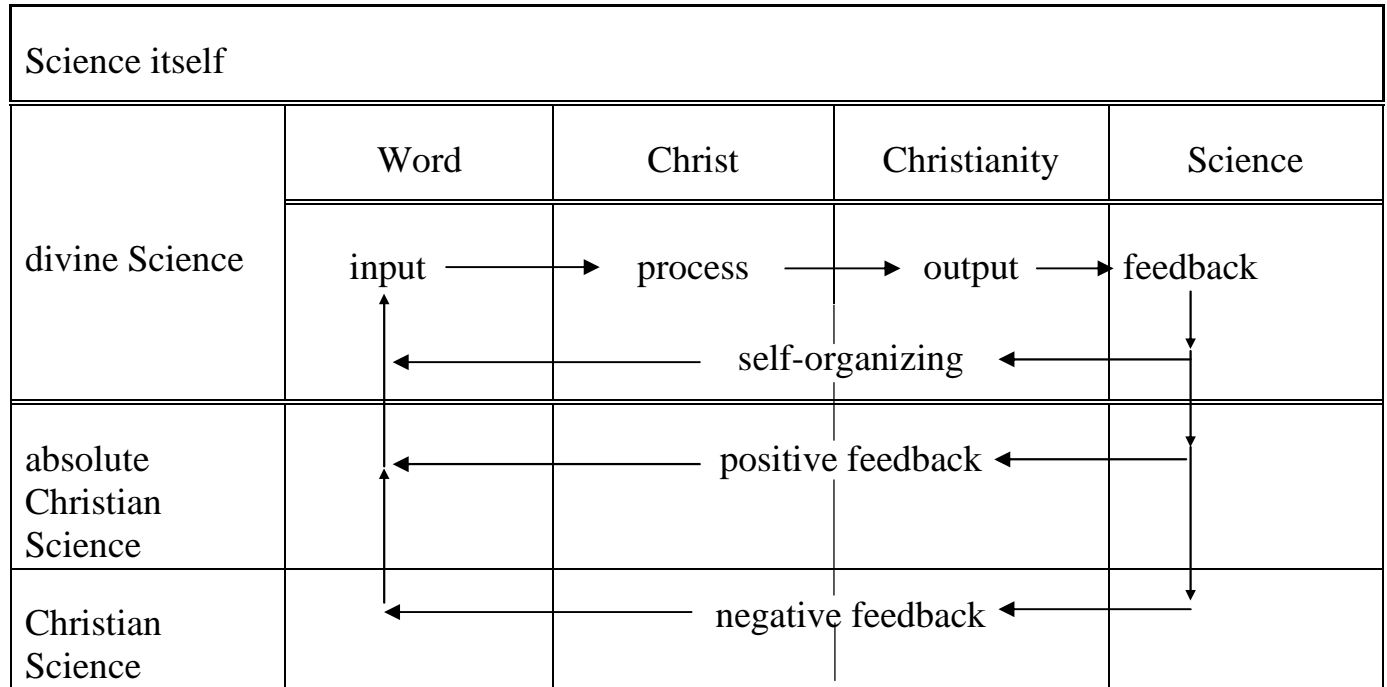

divine cybernetics presents:

Science itself	the one infinite Being
divine Science	as a self-organizing system, running on a self-regulating circuit
absolute Christian Science	that has positive feedback (is error-preventing)
Christian Science	as well as negative feedback (is error-correcting)

Recommended references for studying this subject:

Recordings by Max Kappeler:

- | | |
|--|---|
| <p>B-1: <i>A Survey of the Fundamentals of Christian Science</i>, hours 9–10.</p> <p>B-2: <i>From Atomistic Thinking to Cybernetic Comprehensive Consciousness</i>, 1970, Ogunquit, ME, hour 20B.</p> <p>D-2: <i>Divine Cybernetics: the proto-science, the integral Science</i>, 1969, Braunwald, Switzerland, hours 1–6, 11B (the class goes on to explain The Model of Being in the light of the cybernetic concept: hours 7–20).</p> | <p>G-2: <i>The Science of Being— as I see it today</i>, Lecture, 1970, London, England, hours 7B–8.</p> <p>X-15: <i>Divine Cybernetics</i>, (hours 9–10 from B-1).</p> <p>Books by Max Kappeler:
 <i>The Four Levels of Spiritual Consciousness: Science itself, divine Science, absolute Christian Science, Christian Science</i>, p. 49.</p> |
|--|---|

From Atomistic Thinking to Cybernetic Comprehensive Consciousness – Audio Code B-2

© 1970, 2005 Kappeler Institute for the Science of Being, PO Box 99735, Seattle, WA 98139-0735. All rights reserved.

Oneness
in “Science and Health with Key to the Scriptures”, by Mary Baker Eddy, Chapters I–XVI

	WORD Man’s unity with God	CHRIST God’s unity with man	CHRISTIANITY One universe = God-idea	SCIENCE One integrated Science
Word W	<i>I. PRAYER</i> Acceptance of man’s unity with God. A petitioner separated from God.	<i>V. ANIMAL MAGNETISM UNMASKED</i> Only one standpoint is at work: God. God only knows good. Going out from another standpoint than God. God works good and evil.	<i>IX. CREATION</i> Only one universe, the universe of the infinite One. A finite and an infinite universe.	<i>XIII. TEACHING CHRISTIAN SCIENCE</i> Only like can understand like. Knowing Science through Science. Instructing ignorance so as to become understanding.
Christ X	<i>II. ATONEMENT AND EUCHARIST</i> Exemplification of man’s unity with God, out of at-one-ment with God’s power. Man atoning out of himself or through vicarious efforts.	<i>VI. SCIENCE, THEOLOGY, MEDICINE</i> God with us: Immanuel, Revelation, and translation are one. God and we. Man has a mind of his own.	<i>X. SCIENCE OF BEING</i> Only one evolution of the universe: the spiritual. A material and a spiritual evolution.	<i>XIV. RECAPITULATION</i> Principle and idea is one. Science expressing itself through metaphysics. Metaphysics separate from Science.
Christianity Xty	<i>III. MARRIAGE</i> Man’s unity in God is: man’s unity with the universe. Man is an ego of his own.	<i>VII. PHYSIOLOGY</i> God is omnipotent in Truth and in belief. God and all conditions are one. Working from two standpoints. Serving two masters.	<i>XII. SOME OBJECTIONS ANSWERED</i> Principle and practice are one. Understanding separated from demonstration.	<i>XV. GENESIS</i> Principle expresses itself. God and Being is one. Creator and creation.
Science Sc	<i>IV. CHRISTIAN SCIENCE VERSUS SPIRITUALISM</i> Indivisibility of Spirit. Man’s understanding of God and God’s understanding are one Dividing Spirit into spirits. Understanding God with mortal’s understanding.	<i>VIII. FOOTSTEPS OF TRUTH</i> The coincidence of the divine and the human. There is only one I or Ego. Divinity separated from humanity. The personal I separated from the divine I.	<i>XII. CHRISTIAN SCIENCE PRACTICE</i> The health of God is the health of man. Applying ideas to disease.	<i>XVI. THE APOCALYPSE</i> Principle and idea operate as one complete transparency. Duality dissolved.

From Metaphysics to Science

The ordered steps to finding our oneness with Being (Resolving the “personal I” into the “I Am”)

ascending way

Metaphysics: the contemplation of ideas

1. All is mental (*cogito, ergo sum*)
2. The mental can be good or evil
3. Thinking in terms of ideas
4. Thinking in terms of the synonyms for God

Science: the contemplation of the infinite One, including all ideas

5. Only the synonyms for God in us can be one with synonym of God
6. Life, Truth, and Love is the only “I” of us
7. The synonyms of God are the only “I” or Ego
8. The “I” is “I AM”

descending way

Science:

8. I AM that I Am
7. This I AM is the “I am” of all
6. This I AM is infinitely individualized as “individual I am”
5. This I AM has no other “I Am,” no “personal I”

Science including metaphysics:

4. This I AM is “the thinker” of us
3. This I AM gives us ideas/makes God’s thoughts and “my” thoughts identical
2. This I AM gives only good thoughts
1. This I AM makes us “the thought of” God and therefore, “I am” (*cogitor, ergo sum*)

References for “From Metaphysics to Science: The ordered steps to finding man’s oneness with Being”:

Books by Max Kappeler:

The Four Levels of Spiritual Consciousness: Science itself, divine Science, absolute Christian Science, Christian Science, pp. 7–9, 55–59.

From metaphysics to Science:

Books by Max Kappeler:

Animal Magnetism—Unmasked, pp. 184–192.

Books by John Doorly:

Talks at the Oxford Summer School, 1948, Vol. II, pp. 118–120.

Talks at the Oxford Summer School, 1949, Vol. II, pp. 131–132.

Recordings by Max Kappeler:

- B-2: *From Atomistic Thinking to Cybernetic Comprehensive Consciousness*, 1970, Ogunquit, ME, hour 23.
- D-2: *Divine Cybernetics: the proto-science, the integral Science*, 1969, Braunwald, Switzerland, hours 6–7.
- X-13: *The Eight Ordered Steps to Finding our Oneness with Being*, one hour from B2 (#23).

Recordings by Max Kappeler:

- A-4: *The Structure-principle of Being*, 1974, Wilmington, DE, hour 23.
- A-5: *A Seminar on the Seven Synonymous Terms for God*, 1975, Wilmington, DE, hours 19B-21
- C-1S: *CH. VI, Science, Theology, Medicine, The Structure of the Christian Science Textbook—Our Way of Life*, 1978, hours 10–11, 37
- B-1: *A Survey of the Fundamentals of Christian Science*, hours 3B–4.
- D-1: *The 4 Levels of Science*, 1967/68, London, England, hours 1, 6A.
- X-8: *Metaphysics contrasted with Science*, 2 hours from A-5 (#19B, 20, 21).

ascending way of understanding and descending way of demonstration:

Books by Max Kappeler:

The Four Levels of Spiritual Consciousness: Science itself, divine Science, absolute Christian Science, Christian Science, pp. 74–77.

Books by John Doorly:

Talks at the Oxford Summer School, 1949, Vol. I, pp. 21–24.

Talks on the Science of the Bible, #59 “blue-book,” pp. 13–16.

Talks on the Science of the Bible, #61 “blue-book,” pp. 3–10, 31–32 (progressive from objective to the subjective viewpoint).

Recordings by Max Kappeler:

- D-1: *The 4 Levels of Science*, 1967/68, London, England, hours 8B, 17–20.

ascending and descending in ‘The Apocalypse’:

Books by Max Kappeler:

The Structure of the Christian Science Textbook, Vol. I, pp. 177–185.

The Science of the Oneness of Being in the Christian Science Textbook, pp. 239–248.

Epitomes for the Spiritually Structured Interpretation of the Christian Science, ‘The Apocalypse’, pp. 3–4.

Books by John Doorly:

Talks on the Science of the Bible, #58 “blue-book,” pp. 9–16

From Atomistic Thinking to Cybernetic Comprehensive Consciousness – Audio Code B-2

© 1970, 2005 Kappeler Institute for the Science of Being, PO Box 99735, Seattle, WA 98139-0735. All rights reserved.

“ANIMAL MAGNETISM – UNMASKED”

(Development of the subject through the various revisions of *Science and Health with Key to the Scriptures* by Mary Baker Eddy)

Miscellaneous Writings, pp. 222:29–5; *Retrospection and Introspection*, pp. 37:21–38:26, by Mary Baker Eddy

1 st Edition (1875) MIND	No special chapter. The subject was treated in the chapter “Healing the Sick” (16 pages). Accent lies on observation, investigation, inquiring, gaining insight into the subject of mesmerism.
2 nd Edition (1878) SPIRIT	Title of chapter: Mesmerism: (15 pages) Accent is on distinguishing between metaphysics and mesmerism, between “mind” and “Divine mind”.
3 rd Edition SOUL	Title of chapter: “Demonology” (46 pages). Accent is on the malicious abuse of mesmerism, on the <i>modus operandi</i> of malicious malpractice. Now uses “Mind” capitalized. Basis of malpractice is animal nature.
6 th Edition (1883) PRINCIPLE	Title of chapter: “Demonology” (12 pages). Accent is on impersonalizing animal magnetism.
16 th Edition (1886) LIFE	Title of chapter: “Animal Magnetism” (13 pages). Accent is on dragon’s warfare against the woman, animal magnetism warring with the divine idea. Without a knowledge of animal magnetism, error continues and increases. 1886–91 Department on “Animal Magnetism” in Journal 1887 “Ways that are vain: (<i>Miscellany</i> , by Mary Baker Eddy, pp. 210–213)—was not put into Prose Works by Mrs. Eddy. 1889 “Malicious Animal Magnetism” (<i>Christian Science Journal</i> , February). 1890 “A Card” (<i>Christian Science Journal</i> , August).
50 th Edition (1891) TRUTH	Title of chapter: “Animal Magnetism” (7 pages) Text similar to final edition. Dropped all of those passages referring to the struggle and warfare. Accent is on “doing right” which excludes animal magnetism. Evil is no power, no reality, only a belief—belief has not one quality of Truth. There is no transference of mortal thought and willpower. 1899 “What Our Leader Says” (<i>Miscellany</i> , by Mary Baker Eddy, p. 210). “Keep your mind filled with Truth and Love.”
226 th Edition (1902) LOVE	Title of chapter “Animal Magnetism” (7 pages) Accent is on the nothingness of animal magnetism <ul style="list-style-type: none"> ▪ evil is a suppositional lie ▪ the Allness of God, good, is the answer to animal magnetism. 1910 Title “Animal Magnetism Uncovered” 1910 Title “Animal Magnetism Unmasked” (a few months later)

Transcript of the lost 10 minutes of recording Tape B-2 #4B

EDITOR'S NOTE: After Tape 4B ends, there should be an additional 10 minutes or so of recording. This apparently was lost in the transfer from reel-to-reel to 60 minute audiocassette.

Below is the lost section from the original transcript. This transcript is not completely verbatim; it has been edited to aid understanding. There could be errors introduced by the transcriber.

LAST LINE FROM TAPE #4B: "And we've got here a standard, a measuring rod of ideas..."

"...where each term was very different from the other one. So that as we culture that and culture that, we get a round tone of what Mind is, of what Spirit is and what Soul is. Can you see that? That's the way we proceeded.

"Now having found that, we come to a quite different sense of Science. This morning I was taking the definition of what Science is, and I only took one part of it, namely where the dictionary says that:

Science. 'Science is knowledge reduced to law and embodied in a system.'

"It is Science which takes and interprets knowledge and shows the relationships. It's really analysis of what is. That is a scientific method of analysis. It takes an indefinite term, like God, and analyzes it step by step; first in the great categories of the synonymous terms, and then in further classifications of the ideas characterizing each synonymous term. But, the definition of Science goes further, and this is a major point, one which I want to make during these two weeks with you. One very important point—which raises opposition and query, but I am a tough old guy, you know, and if I see something which is right, I just go for it—Science is not only something which is used to analyze a situation, but Science should also give us the means of being creative. Oxford Dictionary says under the definition of Science that it is:

Science. 'A branch of study which is concerned either with a connected body of demonstrated truth or with observed facts, systematically classified....'

"That's what we have been doing here. We have systematically classified ideas. Perhaps we have gained about 100 or 120 ideas of Mind, and then perhaps another

100 of Spirit, of Soul perhaps only 50 or so. We had perhaps 500 to 600 definite ideas which we could clearly classify under the seven classifications of the synonymous terms. So we have done what Science demands, namely to classify the main ideas of Being so that those main ideas—which constitute Being—can be brought into a system of reference. As we have seen this morning, we have to classify them and bring them under the system of reference through the synonymous terms.

“But the definition of Science goes on and says:

‘...and which include trustworthy methods for the discovery of new truth within its own domain.’

“Now, this sounds very harmless, but it isn’t at all. It includes trustworthy methods for the discovery of new truth. If we want to apply this to Science, to Christian Science, it means that we want to be a revelator, a discoverer, and not just an analyzer or interpreter. What we have done up to now with the Textbook, you see, all this here, is really just the analysis or the interpretation of God. We do this until we have a real standard of ideas which constitute reality, or which constitute our Being. But now comes the second part of the definition of Science—which is really the main thing of any Science—namely, that when you have analyzed your subject, you begin to discover new Truth in it.”

FIRST LINE TAPE B-2, #5A

“Well, we started yesterday by seeing how atomistic thinking...”

ABBREVIATIONS
used to reference the work of Mary Baker Eddy

Mis.	<i>Miscellaneous Writings</i>
My.	<i>Miscellany</i>
Ret.	<i>Retrospection and Introspection</i>
S&H	References from the Christian Science textbook, <i>Science and Health with Key to the Scriptures</i> by Mary Baker Eddy, will be noted with a page and line number, for example: (465:10).

REFERENCES
for further study

BOOKS by Max Kappeler

A Recent Theory of Evolution and Its Implications
Compendium for the Study of Christian Science
The Four Levels of Spiritual Consciousness: /Science itself, divine Science, absolute Christian Science, Christian Science.
The Science of the Oneness of Being in the Christian Science Textbook
The Seven Synonyms for God

RECORDINGS by Max Kappeler

A-4 *The Structure-principle of Being*, 1974, Wilmington, DE
A-6V *Syllabus V*, 1980
B-1 *A Survey of the Fundamentals of Christian Science*
B-2 *From Atomistic Thinking to Cybernetic Comprehensive Consciousness*, 1970, Ogunquit, ME
D-4 *Divine Cybernetics and the Self-operating “Dimensional Laws” of the One Being, God: Word (Part I), Word (Part II), The Christ (Part III), Christianity (Part IV)*, 1971/72, New York, hour 12B
E-1 *The Structure of Being and its Universal Laws*, 1973, New York
G-2 *The Science of Being—As I See It Today*, 1970, London, England
X-15 *Divine Cybernetics*, (hours #9–10 from B-1).

BOOKS by John W. Doorly

The Pure Science of Christian Science(London: The Foundational Book Company for the John W. Doorly Trust, 1949)

BOOKS by Mary Baker Eddy

Miscellaneous Writings
Miscellany
Retrospection and Introspection
Science and Health with Key to the Scriptures

From Atomistic Thinking to Cybernetic Comprehensive Consciousness – Audio Code B-2

© 1970, 2005 Kappeler Institute for the Science of Being, PO Box 99735, Seattle, WA 98139-0735. All rights reserved.



KAPPELER INSTITUTE RECORDINGS

ILLUSTRATIVE MATERIAL

**CHRISTIAN SCIENCE PRACTICE:
BASED ON THE SCIENCE OF DIVINE REVELATION
(Audio Code B-3)**

Max Kappeler

©1976, ©2005 Kappeler Institute for the Science of Being
All rights reserved



Kappeler Institute Publishing
P.O. Box 99735
Seattle, WA 98139-0735
Tel: (206) 286-1617 • Fax: (206) 286-1675
mail@kappelerinstitute.org
www.kappelerinstitute.org
Division of Kappeler Institute for the Science of Being, USA
Seattle, WA USA

Contents

Christian Science Practice: Based on the Science of divine revelation

(Audio code: B-3)

©1976, 2005 Kappeler Institute for the Science of Being

RECORDING NUMBER/SIDE	RECORDING SUBJECT
1-A	Introduction: the Christian Science way of life <ul style="list-style-type: none">▪ a new system of reference▪ the theory: the Principle of Being▪ what is the practice?▪ the theory of “Christian Science Practice”
1-B	<ul style="list-style-type: none">▪ ordinary science▪ the theory of “Christian Science Practice”▪ a cultured consciousness reacts automatically▪ the four levels of practice<ul style="list-style-type: none">- practice on the Christian Science level- practice on the level of absolute Christian Science
2-A	<ul style="list-style-type: none">• handling latent error<ul style="list-style-type: none">- practice on the level of divine Science- practice on the Science level▪ theory and practice
2-B	...continued <ul style="list-style-type: none">▪ summary of the theories for practice
3-A thru 6-B	Handling evil
7-A	<ul style="list-style-type: none">▪ methods of handling evil
7-B thru 8-B	<ul style="list-style-type: none">▪ handling evil through the textbook matrix<ul style="list-style-type: none">- “Prayer” through the “Apocalypse”...continued
9-A thru 9-B	Methods of healing practice
10-A	...continued
10-B	<ul style="list-style-type: none">▪ practice of theory▪ practice through the 7

RECORDING NUMBER/SIDE	RECORDING SUBJECT
11-A thru 15-A	<ul style="list-style-type: none"> ▪ the healing practice through the Textbook matrix: “Prayer” through the “Apocalypse” ▪ the matrix gives a structured answer
15-B	<ul style="list-style-type: none"> ▪ healing in the chapter “Christian Science Practice”.
16-A and 16-B	<ul style="list-style-type: none"> ▪ aim, method, and success of healing
17-A	<ul style="list-style-type: none"> - in the W, the X
17-B	<ul style="list-style-type: none"> - in Xty, Sc
18-A	<ul style="list-style-type: none"> ▪ practice on the level of divine Science <ul style="list-style-type: none"> - in the W, X, Xty, and Sc - the law of divine Sc
18-B	<ul style="list-style-type: none"> ...continued ▪ practice on the level of Sc
19-A	<p>Logic in Christian Science</p> <ul style="list-style-type: none"> ▪ classical logic vs. trans-classical logic <ul style="list-style-type: none"> - Textbook as one-valued, divine logic - the principles of classical logic
19-B	<ul style="list-style-type: none"> ▪ dualistic human thinking
20-A	<ul style="list-style-type: none"> ▪ two-value logic in Christian Science <ul style="list-style-type: none"> - two-conceptual logic, understanding, one-value logic, dimensional logic ▪ the duality of Jesus vs. Christ Jesus as one identity
20-B	<ul style="list-style-type: none"> ▪ two-value and one-value thinking ▪ syllogisms ▪ one-value — two-conceptual logic
21-A	<ul style="list-style-type: none"> ▪ understanding leads to oneness ▪ three-value logic ▪ cybernetic logic
21-B	<ul style="list-style-type: none"> ▪ two kinds of intelligence ▪ man, the mortal, obsolete ▪ a new world feeling ▪ Mind, the eternal, constant regulator
22-A	<ul style="list-style-type: none"> ▪ one-value logic vs. mysticism ▪ two-dimensional logic
22-B	<ul style="list-style-type: none"> ▪ translatability brings dimensional logic ▪ four-value logic ▪ Gestalt theory: evaluate the part within the whole
23-A	<ul style="list-style-type: none"> ▪ infinite logic, logic on the levels
23-B	<ul style="list-style-type: none"> ▪ Gestalt logic, paradoxical logic

24-A	Mrs. Eddy as a scientist
24-B	<ul style="list-style-type: none"> ▪ a science of ideas, as it evolved through philosophy to Mrs. Eddy ▪ how Mrs. Eddy reduced divine metaphysics to categories within a system, and evolved a language of spiritual tonality
25-A	<ul style="list-style-type: none"> ▪ the laws of translatability, of transformation ▪ the Science that governs changes, cybernetics ▪ a structural Science ▪ matrices: <ul style="list-style-type: none"> - the value of study through use of a matrix - only structural answers such as Mrs. Eddy gives through the Textbook matrix are complete answers - laws of Being on the levels - the Science of revelation — the “Science of Oneness”

ABBREVIATIONS

M, Sp, So, P, Li, T, Lo	= Mind, Spirit, Soul, Principle, Life, Truth, Love.
W, X, Xty, Sc	= Word, Christ, Christianity, Science.

REFERENCES FOR FURTHER STUDY

Books by Max Kappeler:

A Study Aid for the Science of Christian Science, Kappeler Institute Publishing, ©1984
The Development of the Christian Science Idea and Practice, Kappeler Institute Publishing, ©1970, 2004
Logical Reasoning in Christian Science, pamphlet, Kappeler Institute Publishing, ©1980
Notes on Handling Evil with References from the Works of Mary Baker Eddy, Kappeler Institute Publishing, ©2002

Recordings by Max Kappeler:

A-6II: *Syllabus II*, 1977, hours 22–23.
B-2: *From Atomistic Thinking to Cybernetic Comprehensive Consciousness*, 1970, Ogunquit, ME, hours 15B–16, 24.
B-3 *Christian Science Practice: based on the Science of divine revelation*, 1976, Wilmington, DE, hours 3–8.
C-1AN: *Chapter V, Animal Magnetism Unmasked, The Structure of the Christian Science Textbook—Our Way of Life*, hours 2–4, 7B–8.
C-6: *Exercises in Culturing Consciousness According to the Matrix of the “Science and Health,”* 1976 Ilkley, England, hours 10–11.
G-2: *The Science of Being—As I See It Today*, 1970, London, England, hour 5.
X-5 *The Problem of Handling Evil*, 6 hours from B-3 (hours 3–8).

Christian Science Practice

	Practitioner			Patient
	<i>Love and Mind</i>	<i>Truth and Mind</i>	<i>Life and Soul</i>	<i>Love } Truth } and Spirit Life }</i>
	<i>How he himself must be</i>	<i>The Truth he knows</i>	<i>His Method</i>	
Mind	seeing only perfection	Mind is all	law of Mind	<i>Love + Spirit</i> based on Mind-science
Spirit	good and pure	Spirit is the only reality	Spirit: the only substance	creates order
Soul	selfless	incorporeality and sinlessness of man	rule of Soul: supremacy;	<i>Truth + Spirit</i> translation takes place
Principle	winning his own pardon scientifically	Science and metaphysics: basis of demonstration	government: omnipotence of Principle	reaching every part of the system
Life	experiencing fullness of life; laying down the mortal concept	man maintained by fullness of Life	immortality: self-supporting Life	renewal of Life
Truth	growing into Christian manhood	man's dominion through consciousness	form of man: consciousness of Truth	<i>Life + Spirit</i> eternal life
Love	anticipating fulfillment	man's perfection; no penalty	fulfillment: perfection of Love	perfect health
				solution for every problem

References:

Books by Max Kappeler:

Epitomes for the Spiritually Structured Interpretation of the Christian Science Textbook, pp. 2–10.
The Science of the Oneness of Being in the Christian Science Textbook, pp. 183–196.
The Structure of the Christian Science Textbook, Vol. I, pp. 116–135.

Books by John Doorly:

Christian Science Practice

Recordings by Max Kappeler:

A-4: *The Structure-principle of Being*, 1974, Wilmington, DE, hours 24–25.
 C-6: *Exercises in Culturing Consciousness According to the Matrix of the "Science and Health,"* 1976, Ilkley, England.
 C-1P: *Chapter XII, Christian Science Practice, The Structure of the Christian Science Textbook—Our Way of Life*, 17 hours.

Christian Science Practice: Based on the Science of divine revelation, Audio code B-3

© 1976, 2005 Kappeler Institute for the Science of Being, PO Box 99735, Seattle, WA 98139-0735. All rights reserved.

John Doorly's Matrix
(Word-matrix)*

i j	The Word <i>(God's self-declaration)</i>	The Christ <i>(the Christ-idea)</i>	Christianity <i>(God's infinite self-reflection)</i>	Science <i>(God's self-interpretation as Science)</i>
the Word <i>(creative)</i>	<i>order</i>	<i>manifestation</i>	<i>reflection</i>	<i>numerals of infinity</i>
	MIND SPIRIT SOUL	PRINCIPLE LIFE TRUTH LOVE	PRINCIPLE MIND SOUL SPIRIT	PRINCIPLE SOUL ——— LIFE
the Christ <i>(Christ-selfhood)</i>	<i>identity</i>	<i>translation</i>	<i>reality</i>	<i>infinite calculus</i>
	SOUL PRINCIPLE LIFE	TRUTH LOVE SOUL SPIRIT	SPIRIT LIFE TRUTH	 SPIRIT ——— TRUTH
Christianity <i>(pure demonstration)</i>	<i>line</i>	<i>plane</i>	<i>space</i>	<i>fourth dimension</i>
	LIFE TRUTH	LOVE SOUL SPIRIT MIND	MIND SOUL SPIRIT LIFE TRUTH LOVE	 MIND ——— LOVE
Science <i>(God-being)</i>	<i>omnipotence</i>	<i>omniscience</i>	<i>omnipresence</i>	<i>omni-action</i>
	LIFE TRUTH LOVE	SOUL SPIRIT MIND	LIFE TRUTH LOVE	 PRINCIPLE

*This matrix, developed over the years by John W. Doorly, has since been further elaborated. Specifically, the "i" and "j" indices have been defined as shown in the parentheses; also the matrix as a whole is seen as the Word-matrix.

References: Books by John W. Doorly:

The Pure Science of Christian Science (London: The Foundational Book Company for the John W. Doorly Trust, 1949), 2nd edition, p. 53.
Christian Science Practice (London: The Foundational Book Company for the John W. Doorly Trust, 1949), p. 358.

Christian Science Practice: Based on the Science of divine revelation, Audio code B-3

© 1976, 2005 Kappeler Institute for the Science of Being, PO Box 99735, Seattle, WA 98139-0735. All rights reserved.

The Matrix of Christian Science
(in Science and Health with Key to the Scriptures, by Mary Baker Eddy, Chapters I–XVI)

absolute standpoint (j) relative standpoint (i)	WORD Revelation of God’s nature	CHRIST Translation of God to idea	CHRISTIANITY The realm of ideas	SCIENCE Principle and idea is one
Word Accepting the proposition	CHAPTER I <i>Prayer</i> Revelation of God’s nature by accepting God’s nature in us	CHAPTER V <i>Animal Magnetism Unmasked</i> As we accept the Christ- translation, the ungodlike is translated back into its native nothingness	CHAPTER IX <i>Creation</i> As we accept the realm of ideas, the ideational universe reveals itself to us	CHAPTER XIII <i>Teaching Christian Science</i> By accepting our oneness with Principle, we are Principle-idea
Christ Power of manifestation in spite of error	CHAPTER II <i>Atonement and Eucharist</i> God’s nature manifests itself in us in spite of the ungodlike in us	CHAPTER VI <i>Science, Theology, Medicine</i> The Christ-translation manifests itself by translating the false constituents into the true constituents of Being	CHAPTER X <i>Science of Being</i> The dynamic power of manifestation of ideas dissolves both latent and concrete error	CHAPTER XIV <i>Recapitulation</i> Principle-idea manifests itself as a calculus of ideas and corrects the calculus of human beliefs
Christianity Exalted being	CHAPTER III <i>Marriage</i> God’s nature demonstrates itself in us as a higher humanhood	CHAPTER VII <i>Physiology</i> The Christ-translation translates mortals into immortals	CHAPTER XI <i>Some Objections Answered</i> The perfect reflection of ideas exalts a theoretical Christianity to a practical Christianity	CHAPTER XV <i>Genesis</i> In the oneness of Principle and idea, creation is exalted in its divine Principle
Science Scientific understanding	CHAPTER IV <i>Christian Science vs. Spiritualism</i> God’s nature can be understood only by scientific methods of understanding	CHAPTER VIII <i>Footsteps of Truth</i> The Christ-translation translates an unscientific consciousness into a scientific consciousness	CHAPTER XII <i>Christian Science Practice</i> A scientific understanding of ideas heals	CHAPTER XVI <i>The Apocalypse</i> Scientific understanding recognizes that on all levels of existence, only the idea of Principle is ever going on

References for “The Matrix of Christian Science”

Books by Max Kappeler:

The Development of the Christian Science Idea and Practice ©2004, 2nd edition, pp. 8–18 (the development of the Science and structure of the textbook).

Epitomes for the Spiritually Structured Interpretation of the Christian Science Textbook (the entire book is presents an elaboration of this subject).

The Science of the Oneness of Being in the Christian Science Textbook, Appendix, Table 3, also pp. 263–267.

The Structure of the Christian Science Textbook (the entire book is devoted to explaining this subject).

‘*Stately Science Pauses Not,*’ booklet, pp. 31–47.

When I think of John W. Doorly...II—Introduction to the Matrix Consciousness, ©2002.

Recordings by Max Kappeler:

B-2: *From Atomistic Thinking to Cybernetic Comprehensive Consciousness*, 1970, Ogunquit, ME, hours 13–14.

C-1: *The Structure of the Christian Science Textbook—Our Way of Life*, an extensive series of talks
Series covering both the structure of each chapter and the structure of *Science and Health with Key to the Scriptures* as a whole.

C-2: *The Christian Science Textbook: A workshop on text-interpretation*, an analysis of the structure of the first five chapters to illustrate
Series the structural and scientific method of text-interpretation.

C-4: *The Matrix of “Science and Health”*, 1975, Wilmington, DE, hours 7–24.

C-6: *Exercises in Culturing Consciousness According to the Matrix of “Science and Health,”* 1976, Ilkley, England, 26 hours, especially hours 2B–9A.

E-2: *The Matrix of Immortality: Code of divine laws*, 1974, Wilmington, DE, hours 11–16A.

M-20: *The Structure of the Christian Science Textbook: An Overview*, 2 recordings.

The Matrix of Handling Evil

(in Science and Health with Key to the Scriptures, by Mary Baker Eddy, Chapters I–XVI)

	WORD <i>Evil must be mastered</i>	CHRIST <i>The power of Truth destroys evil; evil has no power</i>	CHRISTIANITY <i>Demonstrating the superiority of good over evil</i>	SCIENCE <i>By proving good, evil is disproved</i>
Word <i>Accepting the proposition</i>	<i>I. Prayer</i> The desire to be delivered from evil: deliver us from evil	<i>V. Animal Magnetism Unmasked</i> Science has the power to despoil evil, for evil is no power, action or law	<i>IX. Creation</i> Mortals must let themselves be used by good instead of by evil	<i>XIII. Teaching Christian Science</i> By resisting, exposing and denouncing evil, the nothingness of evil can be proved
Christ <i>The power of manifestation in spite of error</i>	<i>II. Atonement and Eucharist</i> The command to cast out evil	<i>VI. Science, Theology, Medicine</i> The power of Truth casts out evil	<i>X. Science of Being</i> The somethingness of good demonstrates the nothingness of evil	<i>XIV. Recapitulation</i> In the allness of God, good, evil has no place
Christianity <i>Exalted being</i>	<i>III. Marriage</i> The good must have ascendancy over evil	<i>VII. Physiology</i> The only power of evil is to destroy itself	<i>XI. Some Objections Answered</i> Denying that God either knows evil, made evil, or cooperates with evil	<i>XV. Genesis</i> Truth annihilates the belief in evil by reducing it to its nothingness
Science <i>Scientific understanding</i>	<i>IV. Christian Science vs. Spiritualism</i> Understanding God, good, keeps evil in check	<i>VIII. Footsteps of Truth</i> Discernment of understanding good destroys the so-called power of evil	<i>XII. Christian Science Practice</i> Understanding the supremacy of good causes evil to disappear	<i>XVI. The Apocalypse</i> By understanding God, good, the nothingness of evil is made manifest

References to “The Matrix of Handling Evil”:

Recordings by Max Kappeler:

- A-6II: Syllabus II, 1978, hours 22–23.
- B-2: *From Atomistic Thinking to Cybernetic Comprehensive Consciousness*, 1970, Ogunquit, ME, hours 15B–16, 24.
- B-3 *Christian Science Practice: based on the Science of divine revelation*, 1976, Wilmington, DE, hours 3–8.
- C-1AN: Chapter V, *Animal Magnetism Unmasked, The Structure of the Christian Science Textbook—Our Way of Life*, hours 2–4, 7B–8.
- C-6: *Exercises in Culturing Consciousness According to the Matrix of “Science and Health,”* 1976, Ilkley, England, hours 10–11.
- G-2: *The Science of Being—As I See It Today*, 1970, London, England, hour 5.
- X-5 *The Problem of Handling Evil*, 6 hours from B-3 (hours 3–8).

Books by Max Kappeler:

Animal Magnetism—Unmasked, pp. 47–81.

Notes on Handling Evil with References from the Works of Mary Baker Eddy

Books by John Doorly:

Christian Science Practice, pp. 328–329, 344–346, 349–355.

Talks on the Science of the Bible, #70 “blue-book,” pp. 15–20.

Talks on the Science of the Bible, Vol. VI “red-book,” pp. 108–110, 231–232, 289–290.

Talks on the Science of the Bible, Vol. VII “red-book,” pp. 13–15, 16–19, 42, 83–85, 283–289.



ILLUSTRATIVE MATERIAL

B-6 Complete

includes Illustrative Material for:

B-6I *Fundamental Questions on the Science of Christian Science*
(Part 1): The Steps from Metaphysics to Science

B-6II *Fundamental Questions on the Science of Christian Science*
(Part 2): Advancing Spiritual Consciousness

B-6III *Fundamental Questions on the Science of Christian Science*
(Part 3): The Christ

B-IV *Ascending and Descending in the 4 Levels of Science*

B-V *Structural Consciousness*

Max Kappeler

B-6 Complete

includes Illustrative Material for:

B-6I *Fundamental Questions on the Science of Christian Science*
(Part I): The Steps from Metaphysics to Science

B-6II *Fundamental Questions on the Science of Christian Science*
(Part II): Advancing Spiritual Consciousness

B-6III *Fundamental Questions on the Science of Christian Science*
(Part 3): The Christ

B-6IV *Ascending and Descending in the 4 Levels of Science*

B-6V Structural Consciousness

© 1984, 2011 Kappeler Institute for the Science of Being, USA

Except as permitted under the United States Copyright Act of 1976, no part of this document may be reproduced or distributed in any form or by any means, or stored in a database or retrieval system, without the prior written permission of the Kappeler Institute.



Printed by
Kappeler Institute Publishing USA
Seattle, WA

Division of Kappeler Institute for the Science of Being, USA
PO Box 99735, Seattle WA 98139-0735 • Tel. (206) 286-1617 • FAX (206) 286-1675
www.kappelerinstitute.org • mail@kappelerinstitute.org

B-6 Complete Contents

1	B-6I Fundamental Questions on the Science of Christian Science (Part 1)	1
	Audio Table of Contents	1
2	B-6II Fundamental Questions on the Science of Christian Science (Part 2)	2
	Audio Table of Contents.	2
3	B-6III Fundamental Questions on the Science of Christian Science (Part 3)	3
	Audio Table of Contents.	3
4	B-6IV Ascending and Descending in the 4 Levels of Science	
	No Audio Table of Contents available.	
5	B-6V Structural Consciousness	
	No Audio Table of Contents available.	
A	Appendix A: Science Terminology	5
	Definitions of Scientific Terms.	6
	Science Terminology Worksheet	15
B	Appendix B: Abbreviations	23
	Abbreviations	24
C	Appendix C: Illustrative Materials	26
	Healing/Christian Science Practice (<i>Study Aid</i> p. 36-37)	27
	The method of treatment, An exceptrt from Max Kappeler <i>The Development of the Christian Science Idea and Practice</i>	29
	The Thousand-year Periods (<i>Study Aid</i> p. 28)	35

C Appendix C: Illustrative Materials - *continued*

Christ (self-operation) (<i>Study Aid</i> p. 66)	37
The law of “The Word” (<i>Study Aid</i> p. 83)	38
The Christ-translation (<i>Study Aid</i> p. 49)	39
Ideal ideas (<i>Study Aid</i> p. 51)	41
Christ-order (<i>Study Aid</i> p. 52)	42
Laws (from B-6IV Illustrative Material)	43
Levels of Science (Cultured consciousness).	45
From Metaphysics to Science (<i>Study Aid</i> p. 58)	46
Dimensionalism (against reductionism) (<i>Study Aid</i> p. 59).	48
Model of Being (Study Aid p. 63)	50
Color Schemes	52

Table of Contents
B-6I
Fundamental Questions on the Science of Christian Science (Part 1):
The Steps from Metaphysics to Science

(Tape code: B-6I)
 ©1984, 2006 Kappeler Institute for the Science of Being

AUDIO RECORDING NUMBER/SIDE	SUBJECT
1-A	I. from metaphysics to Science
	▪ metaphysics defined
1-B	- ordinary metaphysics versus divine metaphysics ...continued
2-A	- scientific metaphysics - metaphysics versus Science - Science includes metaphysics, which is a step, an ordered way to understanding
2-B	▪ metaphysical versus scientific thinking:
3-A	M – Sp
	So – Li
3-B	Li – Lo
4-A	▪ metaphysical versus scientific practice
4-B	...continued
	▪ the eight ordered steps - ascending way: 1-4
5-A	▪ review steps 1-4 ...4 continued, 5
5-B	6-8 - descending way: 8
6-A	7-1
6-B	▪ scientific practice continued: - how practice is misunderstood in the Textbook and <i>Prose Works</i> : - method of reversal: Science reverses
7-A	...continued
	- Doorly's method of practice
7-B	- divine Mind-reading
8-A	...Doorly's method continued
8-B	- correspondence between Doorly's method and Mary Baker Eddy's as given in the Textbook, Chapter 12

Table of Contents
B-6II
Fundamental Questions on the Science of Christian Science (Part 2):
Advancing Spiritual Consciousness

(Tape code: B-6II)

©1984, 2006 Kappeler Institute for the Science of Being

AUDIO CASSETTE NUMBER/SIDE	CASSETTE SUBJECT
1-A	II. advancing from a metaphysical to a scientific approach in the 1000-year periods
1-B	<ul style="list-style-type: none"> ▪ symbol and reality: 1st – 6th ▪ the Model of Being chart symbolizes the way to enter the 7th 1000-year period
2-A	<ul style="list-style-type: none"> ▪ implications for interpreting the Bible from the consciousness of the: <ul style="list-style-type: none"> - 4th 1000-year period - 5th 1000-year period
2-B	<ul style="list-style-type: none"> - 6th 1000-year period ▪ how Doorly proceeded to see the Science of the Bible <ul style="list-style-type: none"> - 7th 1000-year period
3-A	<p style="text-align: center;">...continued</p> <ul style="list-style-type: none"> ▪ how we read the Textbook with the consciousness of the: <ul style="list-style-type: none"> 4th to 7th 1000-year periods
3-B	<ul style="list-style-type: none"> ▪ additional note on interpreting the Bible in the 7th 1000-year period
4-A	<ul style="list-style-type: none"> ▪ the advancing form of understanding through the 1000-year periods <ul style="list-style-type: none"> - 4th – 6th - 7th
4-B	<ul style="list-style-type: none"> - recognizing these states of consciousness, we can evaluate where we are
5-A	<ul style="list-style-type: none"> - 7th continued
5-B	<ul style="list-style-type: none"> - Doorly matrix: form of understanding of the 7th period
6-A	<ul style="list-style-type: none"> - the Model of Being: “The Chart”
6-B	<ul style="list-style-type: none"> ▪ demonstration in the 1000-year periods: <ul style="list-style-type: none"> - 4th – 6th: - progress comes with paradigm shifts
7-A	<ul style="list-style-type: none"> ▪ Summary
7-B	<p style="text-align: center;">...continued</p>

Table of Contents
B-6III
Fundamental Questions on the Science of Christian Science (Part 3):
The Christ

(Tape code: B-6III)
 ©1984, 2006 Kappeler Institute for the Science of Being

AUDIO RECORDING NUMBER/SIDE	SUBJECT
1-A	III. The Christ
	<ul style="list-style-type: none"> ▪ the Christ on the levels (see <i>A Study Aid for the Science of Christian Science</i>, Max Kappeler, page 66)
1-B	<ul style="list-style-type: none"> - X/dSc: in <i>S&H</i>, in the “Survey,” synonym symbol - X/aCS: in <i>S&H</i>, in the “Survey,” synonym symbol
2-A	<ul style="list-style-type: none"> ...continued - X/CS: in <i>S&H</i>, in the “Survey,” synonym symbol
2-B	<ul style="list-style-type: none"> - flowing vertically through the tonality of the Christ: dSc, aCS, CS - synonyms representing the X on the levels
3-A	<ul style="list-style-type: none"> ▪ the Christ-translation (see <i>A Study Aid for the Science of Christian Science</i>, Max Kappeler, pages 49–50)
3-B	<ul style="list-style-type: none"> - scientific translation of immortal Mind: divine P, Li, T, Lo, So, Sp, M
4-A	<ul style="list-style-type: none"> ▪ the Christ-order (see <i>A Study Aid for the Science of Christian Science</i>, Max Kappeler, page 52)
4-B	<ul style="list-style-type: none"> - divine synonyms, divine standpoint - human standpoint, when we let it happen
5-A	<ul style="list-style-type: none"> - flowing vertically through the third column of Christ-order (human standpoint, when we let it happen)
5-B	<ul style="list-style-type: none"> - flowing through the divine and human standpoints horizontally
6-A	<ul style="list-style-type: none"> ▪ scientific translation of immortal Mind, man, idea
6-B	<ul style="list-style-type: none"> ...continued
7-A	<ul style="list-style-type: none"> ▪ scientific translation of mortal mind (see <i>A Study Aid for the Science of Christian Science</i>, Max Kappeler, page 49) - conclusions to be drawn from the Christ-translation
7-B	<ul style="list-style-type: none"> ...continued ▪ second translation through the three degrees ▪ third degree vs. the insufficiency of moral qualities

AUDIO
RECORDING
NUMBER/SIDE

SUBJECT

- | | |
|-----|--|
| 8-A | IV. idea, ideas, ideal (see <i>A Study Aid for the Science of Christian Science</i> , Max Kappeler, page 51) <ul style="list-style-type: none">- further implications of the Christ-translation- flowing through Christ-vertical in the Chart |
| 8-B | V. Model of Being – “the Chart” <ul style="list-style-type: none">- the developing understanding that led to “the Chart”- flowing through “the Chart,” the Model of Being |

APPENDIX



Appendix A: Science Terminology

Definitions of Scientific Terms (from <i>Study Aid</i> pp. 111–116).....	6
Science Terminology Worksheet	15

DEFINITIONS¹

of Scientific Terms

used in the Science of Christian Science

calculus

- A process of reasoning by the use of symbols (Webster).
- *Calculus of operations*: A systematic method of treating problems by operating upon (seeing the relationship among) symbols of operation (Webster).
- vs. *combinatorics*: random combining.

References:

Books by John W. Doorly

Talks on the Science of the Bible, Vol. I “red-book,” [1949] pp. 41–43.

Talks on the Science of the Bible, #60 “blue-book,” pp. 4–11, 31–32.

Christian Science Practice, 2nd edition, pp. 308–309.

Publisher: The Foundational Book Company for the John Doorly Trust, London, England [1949].

category

- One of the underlying forms to which any fact known by experience must conform; specifically defined divisions in a system of classification (Webster).
- A class, division, genus, family, or type with which distinctions are made among things for conceptual analysis and classification (Peter A. Angeles: *Dictionary of Philosophy*)
- Any basic idea, concept, notion or principle fundamental to a system of philosophy; an ultimate conceptual form by which knowledge is made possible, providing the foundation for all meaning (ibid.).
- A system of categories is constituted of the pure concepts or principles that provide the necessary structure for understanding. Nothing is intelligible unless put into the framework of these categories. Our understanding of things is formed by the categories. And things themselves are formed by the forces acting in nature which operate according to these categories (ibid.).

References:

Recordings by Max Kappeler

A-6V *Syllabus V*, hour 1

C-1AP *Chapter XVI, The Apocalypse*, The Structure of the Christian Science Textbook—Our Way of Life, hour 1, 2

Books by Max Kappeler

Stately Science Pauses Not..., pp. 16–24

Books by John W. Doorly

Talks on the Science of the Bible, #63 “blue-book,” pp. 3–5, 5–13, (as presented in *The Apocalypse*), [1949].

¹ See Max Kappeler, *A Study Aid for the Science of Christian Science* (Seattle: Kappeler Institute Publishing, 1984), pp. 111–116.

B-6 Complete, Audio recording code B-6I, B-6II, B-6III, B-6IV, B-6V

© 1984, 2011 Kappeler Institute for the Science of Being, PO Box 99735, Seattle, WA 98139-0735. All rights reserved.

classification

- Systematic arrangement in groups or categories according to established criteria (Webster).

combinatorics

- A random combining of categories that yields results not system-intrinsic in being; not using a valid systematic or scientific method for seeing relationships among symbols of operation.

cybernetics

- From the Greek “Kybernetes”: steersman, pilot, controller, governor.
- The study of systems which are self-operating, self-organizing, self-regulating, and self-controlling through their feedback mechanism to exercise adaptive control.

References:

Books by Max Kappeler

A Study Aid for the Science of Christian Science, p. 69.

dimensionalism

- The concept that one identity, when translated to different levels or standpoints of consciousness, can appear in different forms, while at the same time preserving its one, original identity.

References:

Books by Max Kappeler:

The Science of the Oneness of Being in the Christian Science Textbook, pp. 49–51.

The Seven Synonyms for God, Ch. 7.

Recordings by Max Kappeler:

A-4 *The Structure-principle of Being*, hour 20.

A-6V *Syllabus V*, hour 3.

B-2 *From Atomistic Thinking to Cybernetic Comprehensive Consciousness*, hour 17.

D-4 *Divine Cybernetics and the Self-operating “Dimensional Laws” of the One Being, God*, hour 3.

G-2 *The Science of Being—As I See It Today*, hours 6–7.

gestalt

- A unified physical, psychological or symbolic configuration having properties that cannot be derived from its parts (American Heritage Dictionary)
- The basic idea is that the parts of a shape only have meaning by the fact that they belong to a whole, i.e., a shape cannot be split up into its elements without losing the meanings which it possesses as a whole. A form is more than the sum-total of its elements (Encyclopedia of Cybernetics)

References:

Books by Max Kappeler:

The Science of the Oneness of Being in the Christian Science Textbook, pp. 52, 175–176.

B-6 Complete, Audio recording code B-6I, B-6II, B-6III, B-6IV, B-6V

© 1984, 2011 Kappeler Institute for the Science of Being, PO Box 99735, Seattle, WA 98139-0735. All rights reserved.

holism

- The view that an integrated whole has a reality independent of and greater than the sum of its parts (Webster).
- The thesis that wholes, or some wholes, are more than the sums of their parts in the sense that the wholes in question have characteristics that cannot be explained in terms of the properties and relations to one another of their constituents (Harper Dictionary of Modern Thought).
- *holistic explanation*: 1. Explaining phenomena in terms of the functions (purposes, properties, activities) of a whole (form, totality, unity) that is the guiding principle of its parts. 2. Explaining the activity of the parts of a whole in terms of the functions of that whole (Dictionary of Philosophy).

References:

Books by Max Kappeler:

The Science of the Oneness of Being in the Christian Science Textbook,
pp. 23–25, 52–53, 169–176, 179–180.

Books by John W. Doorly

Talks on the Science of the Bible, Vol. III “red-book,” pp. 375–376, [1949].

interpretation

- Root: inter = between
- Pretari = to show, explain, point out (Century Dictionary)

unscientific meaning of “interpretation”:

- 1) To explain what is inexplicit
 - to explain what is unintelligible
 - explanation of what is not immediately plain or explicit (Webster)
 - to interpret the hidden meaning of a parable (Random House)
- 2) Individually subjective
 - to understand and appreciate in the light of individual belief, judgment, interest or circumstance (Webster)
 - to perform or render according to one's understanding or sensibility (Random House)
- 3) Translation
 - translation from one language into another (Webster)
- 4) To interpret by representation
 - to apprehend and represent by means of art, e.g., to show by illustrative representation (Webster)

scientific meaning of “interpretation”:

- 1) Explanation through general principles
 - explanation of actions, events or statements by pointing out inner relationships ... or by relating particulars to general principles (Webster)

- a matter of accentuation according to the context or frame of reference defined by the structure
 - “Knowing this first that no prophecy of the scriptures is of only private interpretation. For the prophecy came not in old time by the will of man: but holy men of God spake as they were moved by the Holy Ghost” (II Peter 1:20, 21)
 - To leave “to mortals’ interpretation ...to identify the meaning is susceptible of abuse owing to one’s ignoranceThe only safety... must lie in confining (the interpretation) to generalities and not specialities” (Mary Baker Eddy: “Essays and Other Footprints” p. 63)
- 2) vs. *interpolate*
- To alter or corrupt by inserting new or foreign matter; especially to change, as a book or a text, by inserting matter that is new or foreign to the purpose of the author (Webster)

References:

Books by Max Kappeler

The Seven Synonyms for God, Ch. 10.

Introduction to the Science of Christian Science, pp. 146–163, 168.

The Four Levels of Spiritual Consciousness, pp. 25–28.

Epitomes for the Spiritually Structured Interpretation of the Christian Science Textbook, pp. 1–11.

The Bible in the Light of Christian Science, Vol. I: Genesis, pp. 1–19.

Only Science Reveals, pp. 1–4, 12–15, 23–25.

References in the booklets Compendium for the Study of Christian Science #1–10, No. 8: “Life,” Appendix I (p. 24)

(showing how a knowledge of the system of ideas enables us to detect the tones of the subjects in the chapter).

Stately Science Pauses Not, pp. 24–27.

Books by John W. Doorly

Talks at the Oxford Summer School, 1948, Vol. I., pp. 89–90, [1948].

Recordings by Max Kappeler

C-2PR Chapter I, Prayer, *The Christian Science Textbook: A workshop on text-interpretation*, #24, 25.

C-1C Chapter IX, Creation, *The Structure of the Christian Science Textbook—Our Way of Life*, #3, 5–7A.

law

- A general statement describing an invariable order or regularity that exists under certain specific conditions (Dictionary of Philosophy).

References:

Books by Max Kappeler

Introduction to the Science of Christian Science, pp. 168–169.

The Science of the Oneness of Being in the Christian Science Textbook, pp. 57–59.

The Minor Prophets in the Light of Christian Science, pp. 26–27, 40–41, 208–209.

Animal Magnetism—Unmasked, pp. 133–140, 169.

Recordings by Max Kappeler

E-1 *The Structure of Being and its Universal Laws*, hour 6B.

matrix (Plural: **matrixes** or **matrices**)

- Womb, place of origin, cradle. The place in which anything is nurtured in its earlier stage (Oxford Dictionary). Source, cause; grid, chessboard pattern.
- The womb. A place or enveloping element within which something originates, takes form, or develops... That which gives form, origin, or foundation to something enclosed or embedded in it (Webster).

B-6 Complete, Audio recording code B-6I, B-6II, B-6III, B-6IV, B-6V

© 1984, 2011 Kappeler Institute for the Science of Being, PO Box 99735, Seattle, WA 98139-0735. All rights reserved.

- A matrix is a schematic model of order. It has columns and rows or lines, which are constructed according to definite rules. The essential requirement is that all the elements in a column or in a row possess a common characteristic (Z. Dienes and E. Golding: *Mathematisches Denken and logische Spiele*, Herder 1966).
- A rectangular array with systematic entries (Prof. Luft).
- A matrix is an arrangement of values in lines and columns (Prof. Muller-Markus: *Wo die Welt nochmals beginnt*, p. 279).

matrix elements

A matrix is a rectangular arrangement of elements. An element is a primary component, in the sense that it is not possible to divide an element and at the same time retain the properties which are relevant to the associative context. Elements form the constituent parts of magnitudes; their interrelation constitutes the structure of a magnitude. Matrices afford a more accessible general view of the functional interconnections of elements within a system (*Lexikon der Planung and Organisation*, 1968).

purpose

- The word “matrix” (denotes) any ability, habit, or skill, any pattern of ordered behavior governed by a “code” of fixed rules (Koestler: *The Act of Creation*).
- A matrix is an aid to remembering the succession of operations. It needs few symbols, as each symbol acquires a special meaning according to its particular box within the grid.
- Matrices themselves provide a very powerful condensed language in which complicated mathematical statements can be expressed simply (Evelyn Sharp: *The Parent’s Guide to the New Mathematics*).
- A matrix is important for categorical, relational and structural thinking (Z. Dimes and E. Golding: *Mathematisches Denken and logische Spiele*, Herder 1966).
- A matrix is a means to the most economic representation (*Mathematik-Duden fur Lehrer*, Mannheim 1969).
- A purely conceptual, not an observable, construct, superseding the last traces of physical detectability (Prof. Muller-Markus).
 - aids structure recognition
 - acts as a memory-support
 - provides a cognizable overall view
 - is a steering mechanism

References:

Books by Max Kappeler

A Study Aid for the Science of Christian Science, p. 96.
The Minor Prophets in the Light of Christian Science, pp. 17–19.
The Science of the Oneness of Being in the Christian Science Textbook, pp. 255–256.

Recordings by Max Kappeler

E-2 *The Matrix of Immortality: Code of divine laws*, hours 1–4A, 20.
 C-4 *The Matrix of “Science and Health”: An overview*, hour 6.
 C-6 *Exercises in Culturing Consciousness According to the Matrix of “Science and Health,”* hours 1B–2A.
 G-2 *The Science of Being—as I see it today*, hours 4–7.

order

- Regular arrangement; any methodical or established succession or harmonious relation; method; system; ...A condition in which everything is so arranged as to play its proper part; as, “order is heaven’s first law” (Pope) (Webster).
- Sequence, disposition; the fixed arrangement formed in the existing constitution of things; a natural, moral or spiritual system in which things proceed according to definite laws (Oxford).
- The sequence or arrangement of things or events, series, succession; a fixed or definite plan, system or law of arrangement; (rhetoric) the placing of words in such a manner as to contribute ...to the clear illustration of the subject (Webster).

References:

Books By Max Kappeler

Stately Science Pauses Not..., pp. 14–16

Books by John W. Doorly

The Pure Science of Christian Science, 3rd edition, pp. 92–93, [1949].

Talks at the Oxford Summer School, 1948, Vol. I., pp. 143–144, 232–233, [1948].

Talks on the Science of the Bible, Vol. I “red-book,” p. 109 No. 70, pp. 15–16 No. 71, pp. 5–9, [1949].

Christian Science Practice, 2nd edition, pp. 21–22, [1949].

paradigm

- worldview or model of understanding and consciousness.
- A universally recognized scientific achievement that for a time provides model problems and solutions to a community of practitioners (Thomas Kuhn: *The Structure of Scientific Revolution*).
- Some accepted examples of actual scientific practice—including law, theory, application, and instrumentation—provide models from which spring particularly coherent traditions of scientific research (ibid.).

References

Recordings by Max Kappeler

E-1 *The Structure of Being and its Universal Laws*, hours 1–4.

science

- Knowledge of a single fact, not known as related to any other, or of many facts not known as having any mutual relations or as comprehended under any general law, does not reach the meaning of science: science is knowledge reduced to law and embodied in a system (Funk & Wagnalls Dictionary).
- A branch of study which is concerned either with a connected body of demonstrated truths or with observed facts systematically classified and more or less colligated by being brought under general laws, and which includes trustworthy methods for the discovery of new truths within its own domain (Oxford).

- “Divinely defined, Science is the atmosphere of God; humanly construed, and according to Webster, it is 'knowledge, duly arranged and referred to general truths and principles on which it is founded, and from which it is derived.' I employ this awe-filled word in both a divine and human sense” (No. 9:25).

References:

Books by Max Kappeler

Why Study Christian Science as a Science?, pp. 5–11.

References in the booklets Compendium for the Study of Christian Science #1–10, No. 1: “Introduction,” pp. 3–6.

Introduction to the Science of Christian Science, pp. 141–145.

Stately Science Pauses Not..., pp. 6–8, 28.

The Science of the Oneness of Being in the Christian Science Textbook, pp. 31–34.

The Four Levels of Spiritual Consciousness: Science itself, divine Science, absolute Christian Science, Christian Science, pp. 24–25.

Books by John W. Doorly

The Pure Science of Christian Science, 3rd edition, p. 92, [1949].

Recordings by Max Kappeler

D-4 *Divine Cybernetics and the Self-operating “Dimensional Laws” of the One Being, God*, hour 1.

M-1 *Why study Christian Science as a Science, (3 hours from C-1PR, #1–3)*.

structure

- From “structura”: to arrange, to fit together, ordering.
- The interrelationships of parts as dominated by the general character of the whole (Webster).
- Structures appear wherever elements combine into a meaningful whole whose arrangements follow definite laws (Wieser).
- A structure is the sum-total of relationships which maintains the communication among the various parts of a whole (Amar).

structuralism

- Is that method of procedure which transforms every problem into a structural problem (Amar).
- In structuralism, the object itself and its various constituents are seen as points of intersection of multitudinous systems of reference (ibid.).
- Structuralism is a mode of thought; structuralism constitutes essentially a method. By method (is meant) any set of rules or regulations which describes and prescribes the operations to be performed upon any matter with the purpose of ordering it and understanding its workings (Michael Lane: Introduction to Structuralism).
- A structure is a system of transformations. Inasmuch as it is a system and not a mere collection of elements and their properties, these transformations involve laws: the structure is preserved or enriched by the interplay of its transformation laws, which never yield results external to the system nor employ elements that are external to it. In short, the notion of structure is comprised of three key ideas: the idea of wholeness, the idea of transformation, and the idea of self-regulation (Jean Piaget: Structuralism).

Eight stages of the development of consciousness

1. atomistic thinking
2. linear thinking
3. functional thinking
4. operational thinking
5. structural consciousness
6. dimensional consciousness
7. cybernetic consciousness
8. comprehensive consciousness

Structural vs. atomistic attitude

<i>structural</i>	<i>atomistic</i>
keeps the whole in view	narrow-minded
considers structure, relationships within and governed by the whole	engulfed in details, pedantic
always has a new perspective	routine, repetitive
center: the whole	center: personal “I”
the whole has its own solution	meeting our own human and material desires

References:

Books by Max Kappeler

- A Study Aid for the Science of Christian Science*, p. 2.
Introduction to the Science of Christian Science, pp. 151–152.
The Science of the Oneness of Being in the Christian Science Textbook, pp. 52–53.
The Bible in the Light of Christian Science, Vol. I: Genesis, pp. 3–11.
Stately Science Pauses Not. . ., pp. 9–12, 31.

Recordings by Max Kappeler

- B-2 *From Atomistic Thinking to Cybernetic Comprehensive Consciousness.*
C-1C *Chapter IX, Creation, The Structure of the Christian Science Textbook—Our Way of Life*, hours 1–2.
C-6 *Exercises in Culturing Consciousness According to the Matrix of “Science and Health,”* hours 1, 20.
D-4 *Divine Cybernetics and the Self-operating “Dimensional Laws” of the One Being, God*, hour 1.
E-1 *The Structure of Being and its Universal Laws*, hours 4–6.
G-2 *The Science of Being—as I see it today*, hours 4–5.
M-12 *The Structural Method of Science*, (2 hours from C-4: #1–2).

synergy

- The additional benefit accruing to a number of systems should they coalesce to form a larger system; the concept reflects the classical idea that the whole is greater than the sum of its parts. Synergy is formally studied as a property of systems by cybernetics (Harper Dictionary of Modern Thought).

References:

Books by Max Kappeler

- The Science of the Oneness of Being in the Christian Science Textbook*, pp. 23–25, 175–176.

B-6 Complete, Audio recording code B-6I, B-6II, B-6III, B-6IV, B-6V

© 1984, 2011 Kappeler Institute for the Science of Being, PO Box 99735, Seattle, WA 98139-0735. All rights reserved.

synonymous

- By synonymous words we usually understand words that coincide or nearly coincide in some part of their meaning, and may hence within certain limits be used interchangeably, while outside of these limits they may differ very greatly in meaning and use. It is the office of a work on synonyms to point out these correspondences and differences, that language may have the flexibility that comes from freedom of selection within the common limits, with the perspicuity and precision that result from exact choice of the fittest word to express each shade of meaning outside of the common limits. To consider synonymous words identical is fatal to accuracy: to forget that they are similar, to some extent equivalent and sometimes interchangeable, is destructive of freedom and variety (Funk & Wagnalls Dictionary).
- Thus synonymous terms: (a) coincide in some part of their meaning and are in this context—in this certain limit—freely interchangeable; yet also (b) have clearly distinguishable differences and are therefore not freely interchangeable outside of context (a).
- *vs. equinymys*: Words identical or completely equivalent in meaning (many linguists maintain that no such words exist, for, in the economy of language, why would there be two rather than one word, if indeed there were no perceivable difference?).

References:

Books by Max Kappeler

The Seven Synonyms for God, Ch. 1.

Introduction to the Science of Christian Science, pp. 30–32.

Why Study Christian Science as a Science?, pp. 14–15.

Stately Science Pauses Not, No. 5, pp. 17–20.

Books by John W. Doorly

The Pure Science of Christian Science, 3rd edition, [1949], pp. 19–20.

Recordings by Max Kappeler

A-1 *An Introduction to the Science of Christian Science*, hours 2–3A

A-5 *A Seminar on the Seven Synonymous Terms for God*, hours 18–23

A-6II *Syllabus II*, #1B–2A

D-4 *Divine Cybernetics and the Self-operating “Dimensional Laws” of the One Being, God*, hour 2A

system

- A regularly interacting or interdependent group of items forming a unified whole (Webster).
- An assemblage of things unified into a consistent whole by a regular interrelationship (interaction, interdependence, interconnection) of its parts (Dictionary of Philosophy).
- An assemblage of things working in a coherent order according to some rational or intelligible principle, plan or method (ibid.).
- The principle or method of operation by which the consistent and coherent order of the whole is achieved and/or explained (ibid.).

References:

Books by Max Kappeler

References in the booklets Compendium for the Study of Christian Science #1–10, No. 1: “Introduction,” pp. 4–5.

Stately Science Pauses Not, pp. 16–24.

Books by John W. Doorly

The Pure Science of Christian Science, 3rd edition, [1949], p. 92

B-6 Complete, Audio recording code B-6I, B-6II, B-6III, B-6IV, B-6V

© 1984, 2011 Kappeler Institute for the Science of Being, PO Box 99735, Seattle, WA 98139-0735. All rights reserved.

Science Terminology Worksheet

The terms below are commonly used and are important to an understanding of Science. You may use this worksheet to write in definitions as you study.

TERM	DEFINITION
3 fundamental categories	
4 levels of Science	
4 modes of operation	
7 synonymous terms	
15 root-notions	
1000-year periods in biblical history	
absolute Christian Science	
All-in-all	
animal magnetism	
ascending way	
being	

Being	
being-building	
calculus	
capitalized terms	
City Foursquare	
Christ Christ-matrix	
Christ-consciousness	
Christ-idea	
Christ-impulsion	
Christ-operation	
Christ-order	
Christ-translation	
Christianity	
Christianity-matrix	

Christianity-order	
Christian Science	
Christian Science Practice	
concept-building	
consciousness-building	
descending way	
demonstration	
divine metaphysics	
divine Mind-reading	
divine Science	
epitome	
error	
false concepts/attitudes	
4 levels of Science and spiritual consciousness	

4-fold calculus	
4-fold operation of Being	
Holy City	
idea(s)	
immortal Mind-reading	
infinite calculus	
law of oneness	
Life	
Love	
man	
manhood	
material sense(s)	
matrix of Being, “matrix of immortality”	
mental anatomy	

mental malpractice	
mesmerism	
metaphysics	
Mind	
Model of Being	
mortal mind	
mortal thoughts	
oneness	
oneness of Being	
personal sense	
Principle	
re-translation	
Science of Christian Science	
Science of Being	

Science Science-matrix	
Science itself	
Science-level	
Science-order	
scientific obstetrics	
sense-testimony	
sevenfold order	
sin	
Spirit	
spiritualism, spiritism	
Soul	
subtone	
synonym-consciousness	
synonymy principle	

system of reference	
the Textbook	
tonality	
tonality-building	
tone	
translation	
Truth	
understanding (and demonstration)	
womanhood	
Word	
Word-order	

Additional Definitions

APPENDIX



Appendix B: Abbreviations

Abbreviations used in Kappeler's works. 24

Abbreviations²⁴ used in Kappeler's works

The following abbreviations are used throughout Kappeler's writings and recordings:

M, Sp, So, P, Li, T, Lo = Mind, Spirit, Soul, Principle, Life, Truth, Love

W, X, Xty, Sc = Word, Christ, Christianity, Science

Sc, dSc, aCS, CS = Science itself, divine Science, absolute Christian Science, Christian Science

M – Lo = the sequence of Mind through Love

M/M – M/P = Mind in its subtone of M, Sp, So, P (Mind as Mind, etc.)

MIND, SPIRIT, etc. = in all capitals means that tone is the main tone

W/W, W/X, W/Xty, W/Sc = the Word in its subtone of Christ, Christianity, Science

CS - SC = the ascending way of Christian Science to Science

> < = versus

c. of = counterfeit of

vs = versus

The works of Mary Baker Eddy (MBE)

S&H = Science and Health with Key to the Scriptures

Mis. = Miscellaneous Writings

Man. = Manual of the Mother Church

Chr. = Christ and Christmas

Ret. = Retrospection and Introspection

Un. = Unity of God

Pul. = Pulpit and Press

Rud. = Rudimental Divine Science

No. = No and Yes

'00 = Message to the Mother Church, June 1900

'01 = Message to the Mother Church, June 1901

'02 = Message to the Mother Church, June 1902

Hea. = Christian Healing

Peo. = The People's Idea of God

My. = The First Church of Christ, Scientist, and Miscellany

²⁴ See Max Kappeler, *A Study Aid for the Science of Christian Science* (Seattle: Kappeler Institute Publishing USA, 1984), pp. iii-iv.

B-6 Complete, Audio recording code B-6I, B-6II, B-6III, B-6IV, B-6V

© 1984, 2011 Kappeler Institute for the Science of Being, PO Box 99735, Seattle, WA 98139-0735. All rights reserved.

The Works of John W. Doorly (JWD)

- Bible-talks = *Talks on the Science of the Bible*
Oxford-talks = *Talks at the Oxford Summer School*
Statement = *A Statement by John W. Doorly*

Books by other authors

- Coll. = Course in Divinity and General Collectanea, Compiled by Gilbert Carpenter, © Richard F. Oakes, ed. (South Africa: Rustica Press, 1958)

The Works of Max Kappeler (MK)

Books:

- A. M. book = *Animal Magnetism—Unmasked*
Bible-books = *The Bible in the Light of Christian Science, Vols. I–IV*
compendium = *Compendium for the Study of Christian Science, #1–10*
development-book = *The Development of the Christian Science Idea and Practice*
epistle-book = *The Epistles in the Light of Christian Science*
epitome-book = *Epitomes for the Spiritually Structured Interpretation of the Christian Science Textbook*
government = *Christian Science Government*
introduction-book = *Introduction to the Science of Christian Science*
level-book = *The Four Levels of Spiritual Consciousness*
oneness-book = *The Science of the Oneness of Being in the Christian Science Textbook*
prophet-book = *The Minor Prophets in the Light of Christian Science*
study aid = *A Study Aid for the Science of Christian Science*
structure-book = *The Structure of the Christian Science Textbook—Our Way of Life, Vol. I: Revelation of the Structure*
synonym-book = *The Seven Synonyms for God*

Audio/Videotapes

References for audio/video sets are identified by the recording (or “tape”) code, then title, followed by the hours.

An example of an audio recording reference would be: D-4 *Divine Cybernetics and the Self-operating “Dimensional Laws” of the One Being, God, #1*. This references the *first hour* of the D-4 recorded lecture series.

APPENDIX

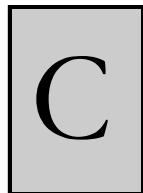

Appendix C: Illustrative Materials

Healing/Christian Science Practice (<i>Study Aid</i> p. 36-37)	27
The method of treatment, An excerpt from Max Kappeler <i>The Development of the Christian Science Idea and Practice</i>	29
The Thousand-year Periods (<i>Study Aid</i> p. 28)	35
Christ (self-operation) (<i>Study Aid</i> p. 66)	37
The law of “The Word” (<i>Study Aid</i> p. 83)	38
The Christ-translation (<i>Study Aid</i> p. 49)	39
Ideal ideas (<i>Study Aid</i> p. 51)	41
Christ-order (<i>Study Aid</i> p. 52)	42
Laws (from B-6IV Illustrative Material)	43
Levels of Science (Cultured consciousness)	45
From Metaphysics to Science (<i>Study Aid</i> p. 58)	46
Dimensionalism (against reductionism) (<i>Study Aid</i> p. 59).	48
Model of Being (<i>Study Aid</i> p. 63).	50
Color Schemes	52

From *Study Aid* page 36

Healing

John Doorly's method of treatment

1. The practitioner begins his treatment by putting the whole problem, including all the suggestions, behind him.
2. The practitioner turns to the infinite Mind.
3. The true identity of what is called a problem appears.
4. The true idea uncovers the governing error.
5. The specific error is compensated by the fullness of the specific truth.
6. The divine idea is omnipotent in the realm of Truth *and* in the realm of human belief.
7. Every Christian Science treatment blesses.

**For further study on the subject of healing in general
see the following references**

The development of the healing practice:

Books by Max Kappeler:

Max Kappeler, *The Development of the Christian Science Idea and Practice* (Seattle: Kappeler Institute Publishing, 2004) pp.71–83

Max Kappeler, *A Study Aid for the Science of Christian Science* (Seattle: Kappeler Institute Publishing, 1984) p. 36

Max Kappeler, *The Four Levels of Spiritual Consciousness* (Seattle: Kappeler Institute Publishing, 1984) p. 36

Recordings by Max Kappeler:

D-1 *The Four Levels of Science* (Seattle: Kappeler Institute Recordings), hours 21–23

Healing on the levels of Science:

Books by Max Kappeler:

Max Kappeler, *The Four Levels of Spiritual Consciousness* (Seattle: Kappeler Institute Publishing, 1984) pp. 86-87

Max Kappeler, *The Development of the Christian Science Idea and Practice* (Seattle: Kappeler Institute Publishing, 2004) pp.62–95

Healing on the levels of Science (continued):

Recordings by Max Kappeler:

D-1 *The 4 Levels of Science* (Seattle: Kappeler Institute Recordings), hour 24

D-2 *Divine Cybernetics: The proto-science, the integral Science* (Seattle: Kappeler Institute Recordings), hours 8–10

B-3 *Christian Science Practice: Based on the Science of divine revelation* (Seattle: Kappeler Institute Recordings), hours 11–15 (also listed separately as M-35)

B-6 Complete, Audio recording code B-6I, B-6II, B-6III, B-6IV, B-6V

© 1984, 2011 Kappeler Institute for the Science of Being, PO Box 99735, Seattle, WA 98139-0735. All rights reserved.

From Study Aid page 37

Christian Science Practice

	Practitioner			Patient
	<i>Love and Mind</i> <i>How he himself must be</i>	<i>Truth and Mind</i> <i>The Truth he knows</i>	<i>Life and Soul</i> <i>His Method</i>	<i>Love</i> } <i>Truth</i> } <i>and Spirit</i> <i>Life</i> } <i>Healing process</i>
Mind	seeing only perfection	Mind is all	law of Mind	<i>Love + Spirit</i> based on Mind-science
Spirit	good and pure	Spirit is the only reality	Spirit: the only substance	creates order
Soul	selfless	incorporeality and sinlessness of man	rule of Soul: supremacy;	<i>Truth + Spirit</i> translation takes place
Principle	winning his own pardon scientifically	Science and metaphysics: basis of demonstration	government: omnipotence of Principle	reaching every part of the system
Life	experiencing fullness of life; laying down the mortal concept	man maintained by fullness of Life	immortality: self-supporting Life	renewal of Life
Truth	growing into Christian manhood	man's dominion through consciousness	form of man: consciousness of Truth	<i>Life + Spirit</i> eternal life
Love	anticipating fulfillment	man's perfection; no penalty	fulfillment: perfection of Love	perfect health
				solution for every problem

**An excerpt from
Max Kappeler
*The Development of the Christian Science Idea and Practice*²**

The method of treatment. Doorly's treatment can be summarized in the following method of treatment:

1. *The practitioner begins the treatment by putting the whole problem, including all the suggestions, behind him.* Sickness, like any other inharmony, is effect, the cause of which is always mortal mind and, therefore, is always mental. No matter what the problem may be, whether it calls itself functional or organic, acute or chronic disease, mental or psychic inharmony, lack of supply or difficulties of relationship, the cause is always that the patient is not in conscious consonance with the divine Mind. Thereby, one can suffer from any individual belief, but mostly from a collective or universal belief, and be ruled by unconscious or subconscious errors. Mortal mind is a belief of many hues and yet it is still always one and the same thing: the misinterpretation of the omnipotent, omniscient, omnipresent, and omniactive divine Mind. The problem itself, of body and sickness, are lies, and these can never inform us of the truth; therefore, they give us no answer. The best thing to do is to turn entirely away from this lie, to be "absent from the body, and to be present with the Lord" (II Cor. 5:8). Treatment begins with the recognition that the "remedy lies in forgetting the whole thing" (S&H 165:19). "The Christian Scientist takes the best care of his body when he leaves it most out of his thought" (S&H 383:7).

Not only the problem, as such, has to be excluded from the treatment, but also the patient as a person. The Christian Scientist never treats a person; he understands that evil "is neither person, place, nor thing," that the patient is ignorant about the truth of his problem (or he would not be sick), that "the sinner created nether himself nor sin, but sin created the sinner; that is, error made its man mortal" (Ret. 67:18), that "the believer and belief are one and are mortal" (S&H 487:17). Every inharmony is the result of mortal mind, an erroneous belief and, as such, impersonal. The practitioner detaches the problem from the person, and therefore, does not need to know his name, the name of the disease, nor any other thing about him. It was not Jesus' custom to ask the name of his patients nor the name of their diseases, nor was he interested in knowing which organ was diseased. He knew that "mortal mind and body are one" (S&H 177:8) and that he had only to deal with a mortal belief, about which the patient could give him no reliable information.

Neither the problem, the patient nor the practitioner, is to be included as a factor in the treatment. The real practitioner is not a person, but God, divine being, itself. God said: "I am the Lord that healeth thee" (Ex. 15:26). Truth is the true physician, surgeon, healer, savior, redeemer; persons have no spiritual healing power. Jesus did not heal as a person: "the Father that dwelleth in me, he doeth the works" (John 14:10). The Son can do nothing of himself, but what he seeth the Father do" (John 5:19). The Christian Scientist does not heal in the name of Christ Jesus, but in the name of Christ, Truth. Mary Baker Eddy said: "All I have ever accomplished has been done by getting Mary out of the way, and letting

²Max Kappeler, *The Development of the Christian Science Idea and Practice* (Seattle: Kappeler Institute Publishing) pp. 53–60 1st edition, © 1970; and pp. 71–83 2nd edition © 2004.

God be reflected” (Coll. p. 185). “That individual is the best healer who asserts himself the least, and thus becomes a transparency for the divine Mind, who is the only physician; the divine Mind is the scientific healer” (Mis. 59:26). When the case of sickness, the patient, and the practitioner as persons, are excluded from the treatment as factors, the way is free for spiritual treatment.

2. *The practitioner turns to the infinite Mind.* It is not enough to turn away from the problem with all that is related to it and say: There is no problem, and leave it at that. In such a case there would just be a vacuum and the patient would not receive anything constructive. Merely “to be absent from the body” does not solve the case; we have also “to be present with the Lord” (S&H 14:3–4), with Truth and Love. The moment we are faced with a problem, thought must turn to God and to the contemplation of divine ideas. “When the thinker is lost in the eminence of Mind, the healing takes place” (Coll. p. 237). As it is the divine birthright of man to have the Mind of Christ, i.e. to have that Mind which is God, the practitioner can proceed from God and its infinite ideas and can understand man—not the patient—as God knows him. Like Jacob, he then sees the mortal (his inimical brother Esau) “as though I had seen the face of God” (Gen. 33:10). The practitioner does not regard his patient as a sinner, as a sick or fallen man; he sees man as the anointed and blessed of God, not with his eyes nor with his human mentality, but with a Christianly scientific consciousness. “Jesus beheld in Science the perfect man, who appeared to him where sinning mortal man appears to mortals” (S&H 476:32). The saving power, the healing power, is in this scientific understanding: “In this perfect man the Savior saw God’s own likeness, and this correct view of man healed the sick” (S&H 477:2).

What is man in “God’s own likeness”? Neither a sick nor a healthy mortal; man is the compound idea of God. Therefore, treatment consists of turning to God and its infinite ideas and contemplating, in consciousness, the true man. What is man when viewed from God? The practitioner knows that because God is Mind, man is intelligent, active, lawful, powerful idea; because God is Spirit, man is the idea of order, enfoldment, reality, and substance; because God is Soul, he is sinless, impeccable, incorporeal, identified, joyous, and satisfied idea; because God is Principle, man is the idea of demonstration, of Science and system, the idea of harmonious government and divine operation; because God is Life, man is the eternal, spontaneous idea of being; because God is Truth, man is the idea of dominion, sonship, divine consciousness, wholeness, and health; because God is Love, man is the idea of perfect fulfillment and salvation, the idea of divine plan.

Consciousness thus rests in the exalted fact that God knows that which is called man only as God’s own idea, without body, person, place, or time. God, divine Being, is conscious of man in an infinitely individual way—without repeating itself. God knows man “before Abraham was.” God knows man only as idea, living, moving, and being in Life, Truth, and Love. In this one divinely united consciousness, man is conscious of his own wholeness and perfection. The practitioner knows that man is conscious of what man truly is and that he is whole.

3. *The true identity of what is called “a problem” appears.* As the practitioner exalts his consciousness and beholds God’s idea from the standpoint of God, and becomes conscious of the true identity of man, the specific identity of what constitutes the counterfact of the so-called problem defines itself to his consciousness. The specific truth about the error to be treated

identifies itself through Soul-sense. The question as to how this is possible has already been answered. Through the law of the identity of Soul the “revelation of divine purpose through spiritual understanding, by which man gains the divine Principle and explanation of all things” (S&H 83:26) takes place in thought. The design of divine Love is to save man and, therefore, Love identifies, through Soul, the saving idea for each human need.

Soul has its own impulsion and infinite means to make itself known to consciousness and to identify the saving idea. The purer consciousness is, the more it is open to the Science of Soul, and the more unmistakably can the constant, true identification be recognized. As soon as the right idea comes, it manifests itself as omnipotence, omniscience, omnipresence, and omni-action; very often this is enough to heal the case. The idea itself operates as omnipotence, having all the power to be victorious over error; it is omniscient and knows, therefore, how to deal with error; it is omnipresent and consequently needs no thought—nor power transference; it is omni-active and works in the realm of Spirit self-operatively—independent of space and time.

4. *The true idea uncovers the governing error.* In the measure that the practitioner “gains the divine Principle and explanation of all things” (ibid.), and the specific truth spiritually identifies itself to him in a given case, it also uncovers, through the law of opposites, that error which, in the mind of the patient, makes his body sick. The error to be treated, the root of the evil, becomes clearly recognizable to pure spiritual consciousness, just as a false note is recognized by the musician. Then it is the true idea of God, and not the right thinking of the practitioner, that has uncovered the error. Every idea uncovers its counterfeit as an illusion. This is the divine diagnosis that makes all other diagnoses superfluous. The Christianly scientific practitioner does not build on a medical diagnosis, because this is of no use even if, medically, the case is diagnosed correctly; nor does he subject his patient to endless questioning to discover some false psychic errors, for even if a wrong inner attitude becomes apparent, this does not mean that it is the specific cause of the sickness to be treated. Only the divine Mind diagnoses correctly. A case is seldom what it seems to be from the medical or psychological point of view.
5. *The specific error is compensated by the fullness of the specific truth.* By (1) analyzing, and (2) uncovering error, it has (3) to be annihilated. “Error found out is two-thirds destroyed, and the last third pierces itself, for the remainder only stimulates and gives scope to higher demonstration” (Mis. 355:13). The fact that error is always a lie about a truth, and the other fact that, through divine Mind-reading, the specific error is being analyzed and uncovered, enables the practitioner to deal with this error with the fullness of the specific truth. He now contemplates the magnitude and potency of this specific idea by seeing it as reflecting all other ideas until its fullness brings to light the wholeness of the idea. In this irradiance of the idea there is no room for anything sick. If, for example, the divine Mind has revealed that the governing error in a case is dissatisfaction, then this points to that fact in being that God, Soul, is always in a state of complete satisfaction. Satisfaction is an idea in the realm of lawful activity (Mind); only spiritual qualities and values can bring forth lasting satisfaction (Spirit); only spiritual sense can experience true satisfaction (Soul); personal sense can never be satisfied, only submission to divine Principle demonstrates satisfaction (Principle); such satisfaction has an exalting and vitalizing influence (Life); it belongs to the true, self-affirming consciousness (Truth); and is constantly in a state of fulfillment, peace, and rest

(Love). With an understanding of the synonymous terms for God and their ideas, the governing truth of any case can be comprehended and “gives scope to higher demonstration” (ibid.).

6. *The divine idea is omnipotent in the realm of Truth and in the realm of human belief.* The divine idea does not only reflect God and all its ideas, it is not only active in the realm of Truth and reality, but it also operates, because of its own truth, in the realm of erroneous beliefs as an irresistible alternative to every error. The idea heals; it saves human consciousness from its own misconception, lifts erroneous thinking out of its self-imposed beliefs into the enlightenment of man’s oneness with the spiritual idea, man, and divine Principle, constantly demonstrating the harmony of being. There is no limit to what the idea can do; its possibilities surpass human conception. Ideas operate on mortal mind and force it to give up the beliefs of material, mortal manhood. The yielding of the false concept shows itself to human thought as an improved material condition, called a healing or salvation.
7. *Every Christian Science treatment blesses.* Every treatment that goes forth from a scientific understanding of Mind, Spirit, Soul, Principle, Life, Truth, and Love, and becomes conscious of the universe of ideas from God’s point of view, moves in its own realm of divine reality. Such a treatment is always an irrepressible truth and cannot help but resolve error; it always heals, it never wanes into nothingness, is never in vain. Perhaps it may not accomplish what we may have wished humanly, for it always fulfills something much higher: that which the divine idea wants to attain. The effects of a scientific treatment go on indefinitely because they partake of the nature of eternal Life. Jesus’ healings are still effective today.

The difference between Doorly’s method of treatment and the earlier methods become evident if we take, as an example, a case of indigestion. Using the method of argument, one would affirm all the facts relative to health and negate all suggestions relative to indigestion; affirm that God has created only a healthy stomach and its healthy activity, that man has only a healthy stomach and that he knows it, that the stomach cannot become sick, that it can neither cause pain nor sickness. Such a method treats the effect—the indigestion—and not the mental cause.

The metaphysical method tries to heal with the idea that indigestion is a lie. The metaphysical practitioner may realize that there is only the “divine digest of Science” (Rud. 3:15); or that there is only “the alchemy of Spirit” (S&H 422:20), if it is a case of acidity; or that “Mind governs the action of the bowels,” if it is a case of constipation.³ This method still proceeds from what the body testifies—rightly or wrongly—and tries to draw conclusions from error to the idea; it is still directed toward healing the body and not man, the effect (disease) and not the mental cause. Such treatment is still on the plane of psychotherapy, building mostly on the so-called “organ-language” of psychosomatic medicine (someone suffering from heart disease is ill because a certain situation in his life “broke his heart”; a patient having trouble with his back indicates that someone or something has “put his back up”; someone cannot move his legs because he would “like to run away” from a situation and cannot; stomach diseases arise because the patient “cannot stomach something.” This metaphysical method, too, is directed toward

³ John W. Doorly, *Christian Science Practice*, 2nd Ed. (London: The Foundational Book Company for the John W. Doorly Trust, 1958), p. 239.

healing the body and not toward healing man, and therefore a relapse to the same disease, or to another, occurs only too often because the real cause had not been diagnosed and corrected divinely.

The method of healing with the oneness of Being sees indigestion as “no-digestion,” because God, Mind, in its infinity has nothing to digest.⁴ Though this is a statement of truth, it does not touch the specific error and is inadequate on two points: first, it still goes out from the sick body with its symptoms and does not touch the mental cause of the disease; second, the healing has to bring about the patient’s healthy digestion and not the concept that he has nothing to digest. For the patient, it is necessary that his organism “returns to the standard which mortal mind has decided upon as essential for health” (S&H 373:32). After the crucifixion, Jesus healed himself, first, to the normality of the body; only later on, at the ascension, did he heal himself on a higher plane, that of divine Science, by freeing himself from the material body and manifesting the purely spiritual body.⁵

The sick body must first be reestablished in its normal functions. This is the purpose of a Christian Science treatment. Such a healing method does not start with indigestion, with the stomach, the body, or a medical diagnosis, nor from what the patient says about it; it starts from God. With the Mind of Christ, the practitioner turns to the all-knowing Mind, which diagnoses the case and reveals, through Mind-reading, the specific idea governing the case. Such spiritual analysis can, for example, reveal that the specific truth is satisfaction, which at once uncovers that the mental cause is dissatisfaction, and the belief of dissatisfaction of life can be resolved through the idea of true satisfaction. In this way, the patient is healed primarily, and his body secondarily. What an enormous difference in the method of treatment when dissatisfaction instead of indigestion is treated!

It is important to note that it should not be concluded from this illustration that dissatisfaction is always the cause of indigestion. The causes of indigestion can be very numerous: belief in heredity, improper nourishment, nervousness, ingratitude, fear, mental contagion, and so on. Which of the innumerable beliefs is to be corrected, in the specific case, is revealed by the divine Mind. Just as dissatisfaction is not the cause of all indigestion, so dissatisfaction does not always manifest itself as indigestion, but as any of the many other diseases. It is unscientific to establish any rule as to what definite relationships exist between mental and psychical causes and the diseases resulting from them. Each case is different; there are no routine cases. Practitioners have to pray anew with each case, so as to be receptive to the revelation of the solution. They do not allow himself to be guided by earlier cases of a similar nature, nor do they let themselves be influenced by the knowledge of psychosomatic medicine or psychotherapy. They take the position: “Let Truth uncover and destroy error in God’s own way” (S&H 542:19).

Though Dooley, in his book “Christian Science Practice,” showed predominantly this Christianly scientific method of treatment, he was very well aware in his latter years that a further development would force itself on us. He indicated that within the framework of the Science of Being there are four different levels of consciousness, namely, (1) Christian Science, (2) absolute Christian Science, (3) divine Science, and (4) Science itself, and that each level

⁴ See Charles S. Braden, *Christian Science Today* (London: George Allen & Unwin Ltd., 1958), p. 312.

⁵ See article “A Correction,” *My.*, p. 217-218.

demands a different method of practice. These essential stages of unfoldment will not be treated extensively here and are only indicated in the following exposition.⁶

⁶ For a more detailed presentation of this subject, see Max Kappeler, *The Four Levels of Spiritual Consciousness: Science itself divine Science, absolute Christian Science, Christian Science* (Seattle: Kappeler Institute Publishing USA, 1970).

From *Study Aid* page 28
The Thousand-year Periods
“One day is with the Lord as a thousand years”
(S&H 504:16–26; 537:19–24)

<i>synonyms</i>	<i>1000-year period</i>	<i>spiritual meaning</i>	<i>symbol/reality</i>
Mind	Adam to Enoch (c. 4000–3000 BC)	awakening from ignorance (the mist of Eden) to follow the light of the spiritual idea (Enoch walks with God)	myth
Spirit	Noah story with the flood to tower of Babel (c. 3000–2000 BC)	turning away from material beliefs to build an ‘ark’ of understanding, remaining with the purity and onliness of spiritual ideas	legends, sagas
Soul	Abraham, Isaac, Jacob, Joseph into Egypt, Moses leading people out of Egypt, entering the Promised Land, Joshua, Judges (c. 2000–1000 BC)	going the way from sense (Ur, Egypt) to Soul (Canaan, the Promised Land), exchanging a physical, corporeal identity for our spiritual selfhood	tribal history
Principle	the Kingdom period and the prophetic age (c. 1000 BC–1 AD)	rejecting personal or material government and finding true government through prophecy, through Principle’s system of ideas	revelation of the idea of God
Life	the life of Jesus, the apostles, Paul and the spreading of Christianity (c. 1–1000 AD)	laying down a mortal, material sense of life and accepting the newness and fullness of Life in and of Spirit as a gift of grace	unity of Jesus and idea (Christ Jesus)
Truth	(c. 1000–2000 AD)	the rise of scientific consciousness, grounding our understanding of true being and manhood in scientific methods	unity of Science and idea (Christ Science)
Love	(c. 2000 AD)	the reign of divine Science and the fulfillment of the Bible’s divine design, bringing in the millennium	God’s consciousness of itself (capitalized terms)

References to the previous diagram:

Books by Max Kappeler:

The Bible in the Light of Christian Science, Vol. I: Genesis, pp. 13–16; more fully, Vols. I–V).

The Four Levels of Spiritual Consciousness: Science itself, divine Science, absolute Christian Science, Christian Science, pp. 29–32, 44–62.

The Minor Prophets in the Light of Christian Science, pp. 1–12.

The Seven Synonyms for God, chapter 2: the seven 1000-year periods; and chapter 10: symbol and reality.

Recordings by Max Kappeler:

A-6III: *Syllabus III*, 1979, Wilmington, DE, hour 16

A-6V: *Syllabus V*, 1980, hours 1–2

B-2: *From Atomistic Thinking to Cybernetic Comprehensive Consciousness*, 1970, Ogunquit, ME, hour 3

C-1G: *Ch. XV, Genesis, The Structure of the Christian Science Textbook—Our Way of Life*, 1981, hours 21–24 (also listed separately as M-13)

D-1: *The 4 Levels of Science*, 1967/68, London, England, hours 3–6A, 9, 17, (from 5th, to 6th, to 7th 1000-year periods)

M-13: *The 1000-year periods in the Bible*, four hours from C-1G (#21–24)

M-18: *Symbol and Reality: Evolving Through the 1000-year Periods in the Bible*, 1 hour

Books by John Doorly:

Christian Science Practice, pp. 29–30, 301–304

God and Science—Symbols and their importance, Publisher: London, F. Muller [©1949], pp. 66–69; more generally, pp. 58–70

Talks on the Science of the Bible, Vol. I “red-book,” pp. 36–37, 52–53, 117–119, 128–130, 132–133, 135–139

Talks on the Science of the Bible, Vol. II “red-book,” pp. 355–356, 363–368 (symbol and reality); statement, pp. 14–15

Talks at the Oxford Summer School, 1948, Vol. I, pp. 29–31

Talks at the Oxford Summer School, 1949, Vol. II, pp. 163–164

Christ
(*self-operation*)

<i>Level</i>	<i>“Science & Health</i>	<i>From “The Survey”</i>	<i>Synonyms for God in “The Chart”</i>
divine Science Principle and idea is one	“Christ is the son of God” “Christ expresses God’s spiritual eternal nature” (333:9). “Christ...is the ideal of God” (361:5) “Christ, Truth”	<i>Son</i> 1. Self-expression 2. Ideal 3. Truth itself	Truth
absolute Christian Science Relationship of Principle to idea	“Christ...is Immanuel or ‘God with us’.” “Christ, the true idea of God” “Christ...leading into all truth” “Christ...furnishes us with absolute evidence”	1. Self-realization 2. Translation of ideal to idea 3. Specific truths <ul style="list-style-type: none"> ▪ Mind-reading 	Truth Life Love
Christian Science Relationship of Truth to error	“Christ casts out evils and heals the sick” (143:3) “Christ turns water into wine” “Christ...improves on a false sense”	1. Manifestation of idea in spite of error 2. Retranslation of mortal mind into the divine Mind 3. Uncovering of specific error	Principle Life Truth Love Soul Spirit Mind

References:

Books by Max Kappeler:

The Four Levels of Spiritual Consciousness: Science itself, divine Science, absolute Christian Science, Christian Science, pp. 95–96, 104–106, 112–113.

Books by John Doorly:

Talks on the Science of the Bible, Vol. VI “red-book,” pp. 210–212 (Christ-vertical in general).

Recordings by Max Kappeler:

D-1 *The 4 Levels of Science*, 1967/68, London, England, hour 19B.

D-2: *Divine Cybernetics: the proto-science, the integral Science*, 1969, Braunwald, Switzerland, hours 16–17A.

D-4: *Divine Cybernetics and the Self-operating “Dimensional Laws” of the One Being, God: Word (Part I), Word (Part II), The Christ (Part III), Christianity (Part IV), Science (Part V)*, 1971/72, New York, hours 13–15.

From *Study Aid* page 83

The law of “The Word” on the level of absolute Christian Science
the law of divine impulsion
(law of divine success-mechanism)

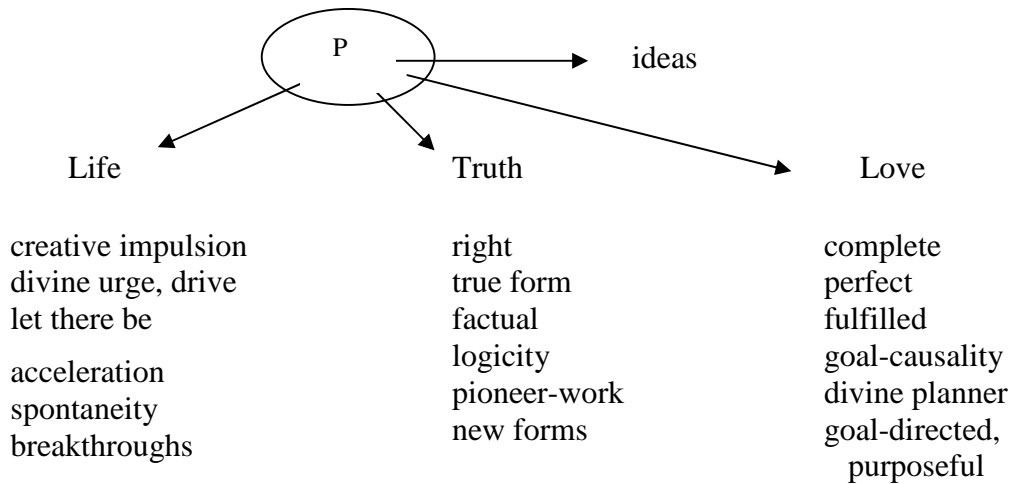

References:

Books by Max Kappeler

The Four Levels of Spiritual Consciousness: Science itself, divine Science, absolute Christian Science, Christian Science, pp. 154–157.

Recordings by Max Kappeler

E-1: *The Structure of Being and its Universal Laws*, 1973, New York, hour 13A.
 D-4: *Divine Cybernetics and the Self-operating “Dimensional Laws” of the One Being, God: Word (Part I), Word (Part II), The Christ (Part III), Christianity (Part IV), Science (Part V)*, 1971/72, New York, hour 7.

The law of “The Christ” on the level of absolute Christian Science

the law of divine individualization
(law of specification)

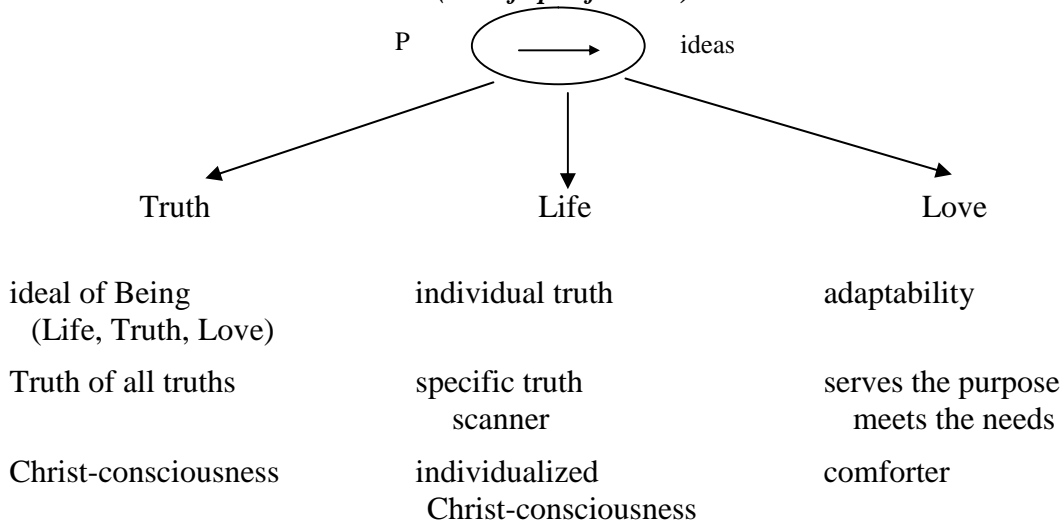

References:

Books by Max Kappeler

The Four Levels of Spiritual Consciousness: Science itself, divine Science, absolute Christian Science, Christian Science, pp. 157–161.

Recordings by Max Kappeler

E-1: *The Structure of Being and its Universal Laws*, 1973, New York, hour 13B.

B-6 Complete, Audio recording code B-6I, B-6II, B-6III, B-6IV, B-6V

© 1984, 2011 Kappeler Institute for the Science of Being, PO Box 99735, Seattle, WA 98139-0735. All rights reserved.

From *Study Aid* page 49
The Christ-translation
(S&H 115:12–116:5)

Scientific translation of immortal Mind

Divine synonyms	GOD:	Divine Principle, Life, Truth, Love, Soul, Spirit, Mind.
Divine image	MAN:	God's spiritual idea, individual, perfect, eternal.
Divine reflection	IDEA:	An image in Mind: the immediate object of understanding. (Webster)

Scientific translation of mortal mind

First Degree: Depravity

Unreality	<i>Physical.</i> Evil beliefs, passions and appetites, fear, depraved will, self-justification, pride, envy, deceit, hatred, revenge, sin, sickness, disease, death.
-----------	--

Second Degree: Evil beliefs disappearing

Transitional qualities	<i>Moral.</i> Humanity, honesty, affection, compassion, hope, faith, meekness, temperance.
------------------------	--

Third Degree: Understanding

Reality	<i>Spiritual.</i> Wisdom, purity, spiritual understanding, spiritual power, love, health, holiness. “In the third degree mortal mind disappears, and man as God's image appears.”
---------	--

References to *The Christ-translation* (S&H 115:12–116:5):

Books by Max Kappeler:

References in the booklet Compendium for the Study of Christian Science #1–10, No. 1:

Introduction, pp. 15–16

Epitomes for the Spiritually Structured Interpretation of the Christian Science Textbook, p. 2

Introduction to the Science of Christian Science, pp. 39–47

The Minor Prophets in the Light of Christian Science, pp. 13–16, 22–25

The Seven Synonyms for God, Chapter 6

Books by John Doorly:

Talks at the Oxford Summer School, 1948, Vol. I, pp. 112–115, 164–166

Talks at the Oxford Summer School, 1948, Vol. II, pp. 138–141

Talks on the Science of the Bible, Vol. I, “red-book,” pp. 71–73

Talks on the Science of the Bible, Vol. II, “red-book,” pp. 27–28, 33–35, 302–304

Talks on the Science of the Bible, Vol. III, “red-book,” pp. 64–65, 292–293, (vs. absolutism or no translatability to the flesh), 272–375

Talks on the Science of the Bible, Vol. IV, “red-book,” pp. 134–135, 150–151, 183–184, 218–219, 238–241, 250–254, 265–270

Talks on the Science of the Bible, Vol. IX, “red-book,” pp. 230–231

Talks on the Science of the Bible, #65 “blue-book,” p. 4–5, 14–15, 21–23

Talks on the Science of the Bible, #66 “blue-book,” pp. 4–5

Talks on the Science of the Bible, #70 “blue-book,” pp. 22–23

Talks on the Science of the Bible, #72 “blue-book,” pp. 5–10

Recordings by Max Kappeler:

A-1: *An Introduction to the Science of Christian Science*, 1962, Zürich, Switzerland, hours 10A–12

A-4: *The Structure-principle of Being*, 1974, Wilmington, DE, hours 17B–19A

A-6IV: *Syllabus IV*, 1980, Elizabethtown, PA, hours 4–5, 9–10

C-1S: *Ch. VI, “Science, Theology, Medicine,” The Structure of the Christian Science Textbook—Our Way of Life*, 1978, hours 14–15

D-4: *Divine Cybernetics and the Self-operating “Dimensional Laws” of the One Being, God: Word (Part I), Word (Part II), The Christ (Part III), Christianity (Part IV), Science (Part V)*, 1971/72, New York, hours 15–16

From Study Aid page 51

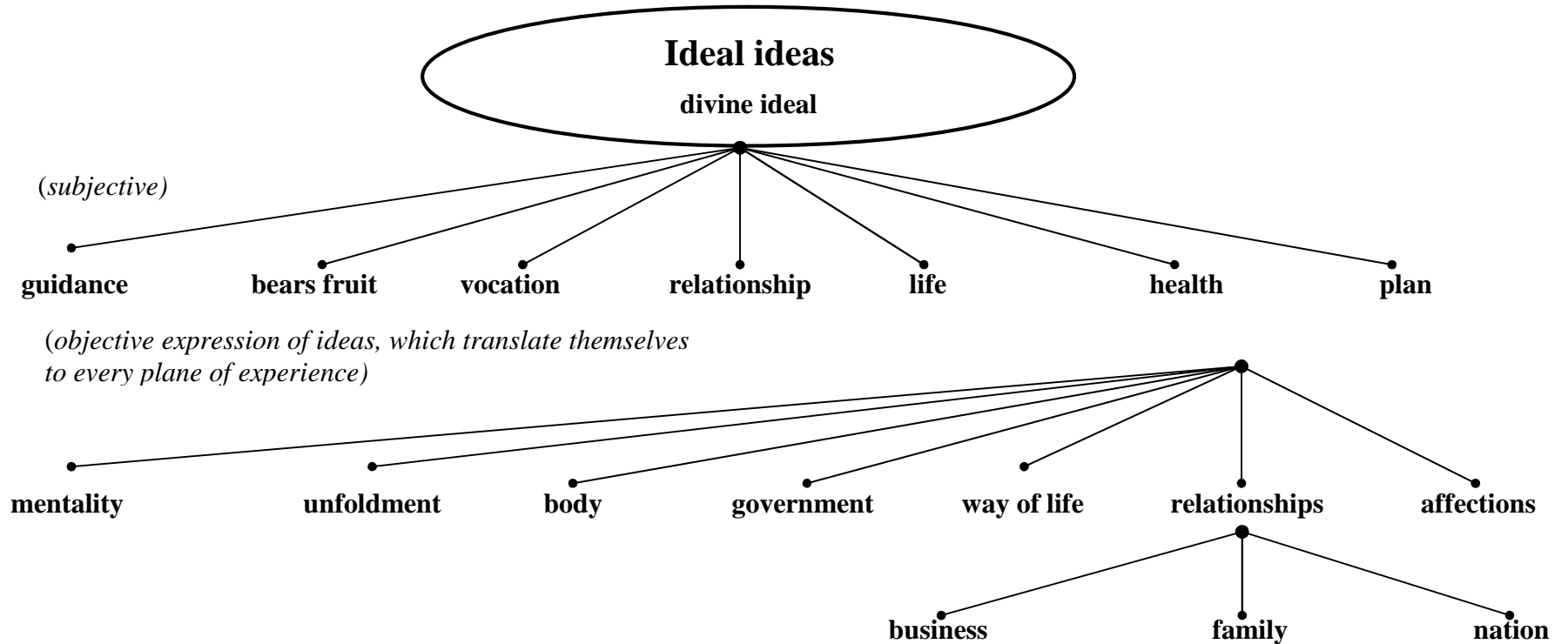

References:

Books by Max Kappeler:

Introduction to the Science of Christian Science, pp. 102–106.

Recordings by Max Kappeler:

A-4: *The Structure-principle of Being*, 1974, Wilmington, DE, hours 6–9.

D-2 *Divine Cybernetics: the proto-science, the integral Science*, 1969, Braunwald, Switzerland, hour 12.

D-4: *Divine Cybernetics and the Self-operating “Dimensional Laws” of the One Being, God: Word (Part I), Word (Part II), The Christ (Part III), Christianity (Part IV), Science (Part V)*, 1971/72, New York, hour 14.

Books by John W. Doorly:

Christian Science Practice, pp. 310–311.

Talks at the Oxford Summer School, 1948, Vol. I, pp. 95–97 (ideas are power).

Talks at the Oxford Summer School, 1949, Vol. II, pp. 140–145 (the nature and operation of ideas), p. 169.

Talks on the Science of the Bible, #70 “blue-book,” pp. 24–25.

Talks on the Science of the Bible, Vol. I “red-book,” pp. 125–126.

Talks on the Science of the Bible, Vol. II “red-book,” pp. 212–213.

Talks on the Science of the Bible, Vol. VI “red-book,” pp. 65–66.

B-6 Complete, Audio recording code B-6I, B-6II, B-6III, B-6IV, B-6V

© 1984, 2011 Kappeler Institute for the Science of Being, PO Box 99735, Seattle, WA 98139-0735. All rights reserved.

Christ-order
the law of translation and reformation

synonyms (S&H: 115)	divine standpoint	human standpoint	
	<i>divinely subjective/objective</i>	<i>when we let it happen</i>	<i>When we resist it</i>
(subjective)			
Principle	potential power	divine authority	imperative – apodictical
Life	dynamic power	spontaneous power – generating power	irrepressible power – irresistible power
Truth	conscious power	penetrating power – dominating power	crushing power
Love	power of total engagement	power of salvation	enforcing power
(objective)			
Soul	identifying power – translating power	transforming power – reverses – exchanges	suffering
Spirit	ordering power – ordering hierarchically	purifying power – excludes – separates	chemicalization – crises – conflict – frustration
Mind	manifesting power	enlightening power – corrects – leads – heals	animal magnetism – ignorance

References:

Books by Max Kappeler:

The Christ-idea, ©1969, 2nd edition 2002.
The Four Levels of Spiritual Consciousness: Science itself, divine Science, absolute Christian Science, Christian Science, pp.187–192.
Introduction to the Science of Christian Science, pp.39–55, 115–124.
The Minor Prophets in the Light of Christian Science, pp. 197–198.
The Seven Synonyms for God, Chapter 6: The Christ-order.

Recordings by Max Kappeler:

A-6IV: *Syllabus IV*, 1980 – Wilmington, (DE), hours 5–8 (hours 11–17: Christ-order illustrated in “Romans”).
D-4: *Divine Cybernetics and the Self-operating “Dimensional Laws” of the One Being, God: Word (Part I), Word (Part II), The Christ (Part III), Christianity (Part IV), Science (Part V)*, 1971/72, New York, hours 13–16.
E-1: *The Structure of Being and its Universal Laws*, 1973, New York, hours 17–19.

Books by John W. Doorly:

Christian Science Practice, pp. 34–35, 174.
Talks at the Oxford Summer School, 1948, Vol. I, pp. 95–97 (ideas are power).
Talks on the Science of the Bible, #67 “blue-book,” pp. 19–25.
Talks on the Science of the Bible, #69 “blue-book,” pp. 10–16.
Talks on the Science of the Bible, Vol. I “red-book,” pp. 219–220.
Talks on the Science of the Bible, Vol. III “red-book,” pp. 367–368, 370.
Talks on the Science of the Bible, Vol. VI “red-book,” pp. 250–254.
Talks on the Science of the Bible, Vol. IX “red-book,” pp. 66–67 (from W-order to X-order).

B-6 Complete, Audio recording code B-6I, B-6II, B-6III, B-6IV, B-6V

© 1984, 2011 Kappeler Institute for the Science of Being, PO Box 99735, Seattle, WA 98139-0735. All rights reserved.

Laws

law of Science itself

the law of infinite being

law of divine Science

the law of divine self-organization

law of absolute Christian Science

the law of spontaneity

1. Word: the law of divine impulsion
(law of divine success-mechanism)
2. Christ: the law of individualization
(law of specification)
3. Christianity: the law of eternalization
(law of self-maintenance)
4. Science: the law of prestabilized perfection

law of Christian Science

the law of causality

1. Word: the law of creativity
2. Christ: the law of translation and reformation
3. Christianity: the law of reflection and demonstration
4. Science: the law of structured understanding

laws of interdependence

- between dSc and aCS in Word, Christ, Christianity, and Science
- between aCS and CS in Word, Christ, Christianity, and Science

laws of the synonyms for God

Mind:	law as such
Spirit:	the ordering law
Soul:	the ruling law
Principle:	the law of government
Life:	the law of renewal
Truth:	the law of self-realization, of healing
Love:	the law of fulfillment

Laws continued

structural laws

- law of integral oneness
- law of invariance
- law of fundamental translatability
- law of hierarchical order
- law of self-regulation (= divine cybernetics)
- law of dynamic equilibrium
- law of complementarity
- law of synergy

References:

Recordings by Max Kappeler:

B-1: *A Survey of the Fundamentals of Christian Science*, 1969, hours 5–8 (a general overview of the Model of Being and its laws).

E-1: *The Structure of Being and its Universal Laws*, 1973, New York, 39 hours.

Levels of Science **Cultured consciousness**

The dimensional aspect of Being: the four levels of Science itself, divine Science, absolute Christian Science, and Christian Science. This development of defining the seven synonymous terms for God and the four sides of the holy city as Word, Christ, Christianity, and Science has brought us up to the time of World War II. Though it seemed that much had been achieved, there was still something missing. Quite a few paradoxical questions remained unsolved, and a fundamental key was needed to solve them. They were the paradoxes that every sincere thinker encounters when studying the Textbook. To take two simple examples:

- Christian Science teaches on the one hand that God knows no sickness and on the other hand that God heals sickness;
- that there is no evil and yet that we have to overcome evil.

For those thinking along the lines of classical logic, such seeming paradoxes or contradictions are encountered again and again in the Textbook. But in fact Mrs. Eddy does not contradict herself, if the Textbook is read with the transclassical logic which she was already using a century before the other sciences and the world awoke to it. As she wrote the Textbook in a structural way and not according to one-dimensional linear reasoning, her teaching can only be understood through a multi-dimensional logic.

John Doorly realized that the subject of the Textbook has various levels of spiritual altitudes and that this is brought out by the various levels of Science. He showed that any subject has a different aspect according to whether it is treated from the point of view of *Science itself*, from *divine Science*, from *absolute Christian Science* or from *Christian Science*. Therefore the student must approach the Christian Science textbook with a consciousness that is cultured in thinking dimensionally with a dimensional logic, and then the seeming paradoxes can be solved even rationally.⁷

⁷ See Max Kappeler, *The Four Levels of Spiritual Consciousness: Science itself, divine Science, absolute Christian Science, Christian Science*.

From Metaphysics to Science

The ordered steps to finding our oneness with Being (Resolving the “personal I” into the “I Am”)

ascending way

Metaphysics: the contemplation of ideas

1. All is mental (*cogito, ergo sum*)
2. The mental can be good or evil
3. Thinking in terms of ideas
4. Thinking in terms of the synonyms for God

Science: the contemplation of the infinite One, including all ideas

5. Only the synonyms for God in us can be one with synonym of God
6. Life, Truth, and Love is the only “I” of us
7. The synonyms of God are the only “I” or Ego
8. The “I” is “I AM”

descending way

Science:

8. I Am that I Am
7. This I Am is the “I am” of all
6. This I Am is infinitely individualized as “individual I am”
5. This I AM has no other “I Am,” no “personal I”

Science including metaphysics:

4. This I AM is “the thinker” of us
3. This I AM gives us ideas/makes God’s thoughts and “my” thoughts identical
2. This I AM gives only good thoughts
1. This I AM makes us “the thought of” God and therefore, “I am” (*cogitor, ergo sum*)

References for “From Metaphysics to Science: The ordered steps to finding man’s oneness with Being”:

Books by Max Kappeler:

The Four Levels of Spiritual Consciousness: Science itself, divine Science, absolute Christian Science, Christian Science, pp. 7–9, 55–59.

From metaphysics to Science:

Books by Max Kappeler:

Animal Magnetism – Unmasked, pp. 184–192.

Books by John Doorly:

Talks at the Oxford Summer School, 1948, Vol. II, pp. 118–120.

Talks at the Oxford Summer School, 1949, Vol. II, pp. 131–132.

Recordings by Max Kappeler:

- B-2: *The Fundamentals of Christian Science*, Class, 1970 – Ogunquit, (ME), hour 23.
D-2: *The Four Levels of Science: their practical implications*, Class, 1969, Braunwald, Switzerland, hours 6–7.
X-13: *The ordered steps to finding man’s oneness with Being*, one cassette from B2 (#23).

Recordings by Max Kappeler:

- A-4: *The Seven Synonymous Terms for God: the structure-principle of Being*, Class 1974 – Wilmington, (DE), hour 23.
A-5: *A Seminar on the Seven Synonymous Terms for God*, Seminar 1975, Wilmington, (DE), hours 19B-21 (also listed separately as X-8): the 7 synonyms from the two standpoints.
C-1S: *The Structure of the Christian Science Textbook, ‘Science, Theology, Medicine’*, Series of Talks: 1978, hours 10–11, 37 (2–3, 29, if numbered from the beginning of the chapter).
B-1: *A Survey of the Fundamentals of Christian Science*, hours 3B–4.
D-1: *The Four Levels of Science*, Series of Talks 1967/68 – London, England, hours 1, 6A.
X-8: *Metaphysics contrasted with Science*, 2 cassettes from A-5 (#19B, 20, 21).

ascending way of understanding and descending way of demonstration:

Books by Max Kappeler:

The Four Levels of Spiritual Consciousness: Science itself, divine Science, absolute Christian Science, Christian Science, pp. 74–77.

Books by John Doorly:

Talks at the Oxford Summer School, 1949, Vol. I, pp. 21–24.

Talks on the Science of the Bible, #59 “blue-book,” pp. 13–16.

Talks on the Science of the Bible, #61 “blue-book,” pp. 3–10, 31–32 (progressive from objective to the subjective viewpoint).

Recordings by Max Kappeler:

- D-1: *The Four Levels of Science*, Series of Talks 1967/68 – London, England, hours 8B, 17–20.

ascending and descending in ‘The Apocalypse’:

Books by Max Kappeler:

The Structure of the Christian Science Textbook, Vol. I, pp. 177–185.

The Science of the Oneness of Being in the Christian Science Textbook, pp. 239–248.

Epitomes for the Spiritually Structured Interpretation of the Christian Science, ‘The Apocalypse’, pp. 3–4.

Books by John Doorly:

Talks on the Science of the Bible, #58 “blue-book,” pp. 9–16

B-6 Complete, Audio recording code B-6I, B-6II, B-6III, B-6IV, B-6V

© 1984, 2011 Kappeler Institute for the Science of Being, PO Box 99735, Seattle, WA 98139-0735. All rights reserved.

From *Study Aid* page 59
DIMENSIONALISM
(against reductionism)

Diagram A

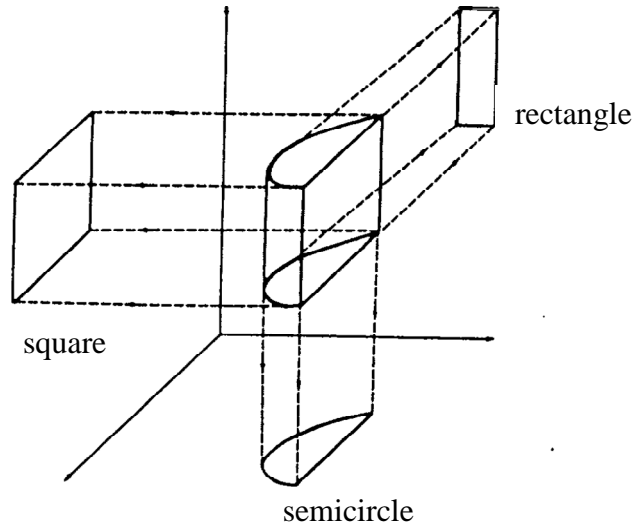

Diagram B

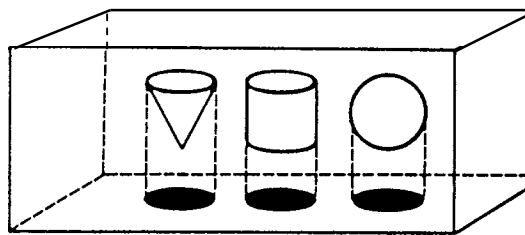
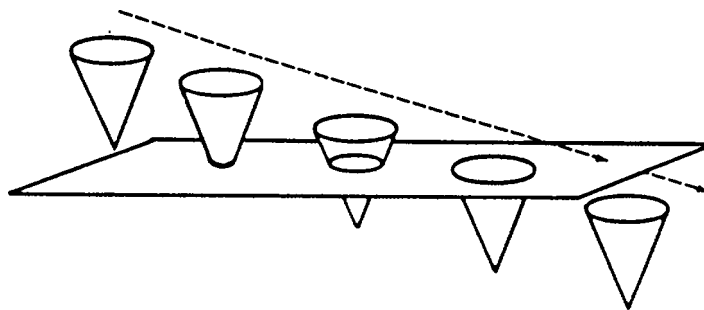

Diagram C



References to Dimensionalism (against reductionism)

Recordings by Max Kappeler:

- A-4: The Seven Synonymous Terms for God: the structure-principle of Being, Class 1974, Wilmington, (DE), hour 20.
- A-6V: *Syllabus V*, 1980, hour 3.
- G-2: *The Science of Being, as I See it Today*, Lecture, 1970 – London, England, hours 6–7.
- B-2: *The Fundamentals of Christian Science*, Class, 1970 – Ogunquit, (ME), hour 17.
- D-4: *Word, Christ, Christianity, and Science in divine Science, absolute Christian Science, and Christian Science*, Series of talks 1971/72 – New York, hour 3.

Books by Max Kappeler:

The Seven Synonyms for God, Chapter 7.

The Science of the Oneness of Being in the Christian Science Textbook, pp. 49–51.

MODEL OF BEING

(The Chart)

Science itself	infinite Principle			
	Word	Christ	Christianity	Science
divine Science	Life	Truth	Love	divine Principle, Love
absolute Christian Science	Life Truth Love	Truth Life Love	Life Love	Truth Love
Christian Science	Mind	Principle Life Truth Love Soul Spirit Mind	Principle Mind Soul Spirit Life Truth Love	Principle ----- Soul Life Spirit Truth Mind Love ----- Principle
	Spirit			
	Soul			
	Principle			
	Life			
	Truth			
	Love			

The 7 Synonymous Terms for God (in Word-order): Mind, Spirit, Soul, Principle, Life, Truth, Love

The 4-fold Operation of Being: Word, Christ, Christianity, Science

The 4 Levels of Spiritual Consciousness: Science itself, divine Science, absolute Christian Science, Christian Science

B-6 Complete, Audio recording code B-6I, B-6II, B-6III, B-6IV, B-6V

© 1984, 2011 Kappeler Institute for the Science of Being, PO Box 99735, Seattle, WA 98139-0735. All rights reserved.

References to the previous matrix: Model of Being “*The Chart*”

Books by Max Kappeler:

The Development of the Christian Science Idea and Practice ©2004, 2nd edition. (healing on the levels)

The Four Levels of Spiritual Consciousness: Science itself, divine Science, absolute Christian Science, Christian Science, pp. 117–198 (the place value of the synonyms on *The Chart*.)

Recordings by Max Kappeler:

A-4: *The Structure-principle of Being: Our need for a divine system of reference*, 1974, Wilmington, DE, hour 21.

A-5: *A Seminar on the 7 Synonymous Terms for God*, 1975, Wilmington, DE, hours 22–23.

A-6V: *Syllabus V*, 1980, hours 13–19.

B-1: *A Survey of the Fundamentals of Christian Science*, hours 5–8, 12.

B-2: *From Atomistic Thinking to Cybernetic Comprehensive Consciousness*, Ogunquit, ME, hours 19–20.

D-1: *The 4 Levels of Science*, 1967/68, London, England, hours 6–9, 13–16.

D-2: *Divine Cybernetics: The proto-science, the integral Science*, Braunwald, Switzerland, hours 8–11.

D-4: *Divine Cybernetics and the Self-operating “Dimensional Laws” of the One Being, God*, 1971/72, New York, hours 5–24.

E-1: *The Structure of Being and its Universal Laws*, 1973, New York, hours 7–38.

G-2: *The Science of Being—As I See It Today*, 1970, London, England, hour 17.

Books by John Doorly:

treated generally in the context of the ascending and descending scales of Science:

Talks at the Oxford Summer School, 1948, Vol. II, pp. 38, 157–158.

Talks at the Oxford Summer School, 1949, Vol. I, pp. 21–24, 49–51.

Talks at the Oxford Summer School, 1949, Vol. II, pp. 268–273 (the story of the one infinite system, including the level of Science itself).

Talks on the Science of the Bible, Vol. I, “red book,” pp. 65–69.

Talks on the Science of the Bible, Vol. III, “red book,” pp. 282–284.

Talks on the Science of the Bible, Vol. VI, “red book,” pp. 207–208.

Talks on the Science of the Bible, #58, “blue book,” pp. 9–16.

Talks on the Science of the Bible, #59, “blue book,” pp. 4–16 (Christian Science to Science itself to Christian Science).

Talks on the Science of the Bible, #61, “blue book,” pp. 3–10, 31–32.

The Pure Science of Christian Science, pp. 65–67 (the city foursquare and the city of our God).

COLOR SCHEMES

Below are the color schemes used by Doorly, Brook, Kappeler, and KI USA. Although the colors used for the 7 synonyms is randomly chosen (you may select any color scheme for your own notes), the colors for the 4-fold operation of Being and 4 levels of Science are derived from the colors selected for Principle, Life, Truth, and Love. Please note this when devising your own color scheme.

John W. Doorly / Peggy Brook

7 Synonyms for God

Mind	red
Spirit	orange
Soul	yellow
Principle	black
Life	green
Truth	blue
Love	purple

Max Kappeler

7 Synonyms for God

Mind	black
Spirit	red
Soul	yellow
Principle	purple
Life	brown
Truth	blue
Love	green

4-fold Operation of Being

Word	(Life)
Christ	(Truth)
Christianity	(Love)
Science	(divine Principle, Love)

4 Levels of Science

Science itself	(infinite Principle)
divine Science	(Love)
absolute Christian Science	(Truth)
Christian Science	(Life)

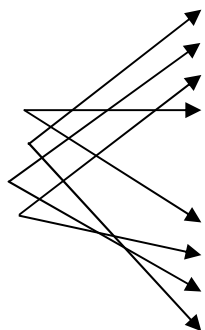

Kappeler Institute USA Publications *(based on the rainbow/prism)*

7 Synonyms for God

Mind	red
Spirit	orange
Soul	yellow
Principle	green
Life	blue
Truth	indigo
Love	violet

4-fold Operation of Being

Word	(Life)
Christ	(Truth)
Christianity	(Love)
Science	(divine Principle, Love)

4 Levels of Science

Science itself	(infinite Principle)
divine Science	(Love)
absolute Christian Science	(Truth)
Christian Science	(Life)

