



**KAPPELER INSTITUTE RECORDINGS**

**ILLUSTRATIVE MATERIAL**

**THE SCIENCE OF BEING—  
AS I SEE IT TODAY**

**(Tape Code G-2)**

**Max Kappeler**

©1970, 2006, Kappeler Institute for the Science of Being  
All rights reserved



Kappeler Institute Publishing  
P.O. Box 99735  
Seattle, WA 98139-0735  
Tel: (206) 286-1617 • Fax: (206) 286-1675  
E-mail: [mail@kappelerinstitute.org](mailto:mail@kappelerinstitute.org)  
[www.kappelerinstitute.org](http://www.kappelerinstitute.org)  
Division of Kappeler Institute for the Science of Being, USA  
Seattle, WA USA

# Contents

## The Science of Being— As I See It Today

(Tape code: G-2)

©1970, 2006 Kappeler Institute for the Science of Being

AUDIO RECORDING NUMBER/SIDE	SUBJECT
1-A	Introduction
1-B	The spiritual idea impelling the acceleration of mutations <ul style="list-style-type: none"><li>♦ examples: population explosion, increased life-span, total knowledge, scientists, science periodicals, validity of world-image; vocabulary, intensification of consciousness, growth in energy available</li><li>♦ the vertical (exponential growth) is the sign of the spiritual, breaking through the horizontal way of thinking.</li></ul>
2-A	Stages in the development of consciousness
2-B	1. Atomistic thinking ...continued
3-A	2. linear-rational thinking
3-B	– order; sequences: <ul style="list-style-type: none"><li>• the evolution of life</li><li>• the 1000-year periods in the Bible</li><li>• the law of creativity</li></ul>
4-A	3. functional thinking
4-B	– the blending or calculus of ideas
5-A	4. operational thinking Word (W), Christ (X), Christianity (Xty), Science (Sc)
5-B	5. structural consciousness
6-A	– a simplifying process
	– classical logical thinking versus structural consciousness
	– definitions of structure
	...continued
	♦ review of the modes of thinking leading to structuralism
	– examples of structural thinking in the world
	– development of structural thinking in Christian Science
	• examples: matrices: 4x4 calculus, prophets-matrix, epistles matrix, synonym- matrices, the matrix of handling evil, Word-matrix, Christ and Christianity matrices

6-B	6. dimensional consciousness ...continued
	– dimensional thinking in the world
7-A	...continued
	– dimensionalism in Christian Science: Sc, dSC, aCS, CS
	– each level alone leads to reductionism
	– the vertical laws
	• example: the “Platform”-matrix: W, X, Xty, Sc/aCS/CS
7-B	– intertwining the fourfold operation with the four levels brings out the laws of Being
	– dimensionalism in the sciences and in philosophy
	7. cybernetic consciousness
8-A	...continued
	– the idea of divine cybernetics as a self-organizing, self-regulating system
8-B	...continued
	8. comprehensive consciousness

---



---

ABBREVIATIONS

M, Sp, So, P, Li, T, Lo	= Mind, Spirit, Soul, Principle, Life, Truth, Love
W, X, Xty, Sc	= Word, Christ, Christianity, Science
Sc, dSc, aCS, CS	= Science, divine Science, absolute Christian Science, Christian Science
I.M.	= Illustrative Material
S.A.	= <i>A Study Aid for the Science of Christian Science</i> , by Max Kappeler
S&H	= <i>Science and Health with Key to the Scriptures</i> , by Mary Baker Eddy
M/M–M/Lo	= Mind as Mind through the 7 synonyms to Mind as Love
Mis.	= <i>Miscellaneous Writings</i> , by Mary Baker Eddy

# The Science of Being—As I See It Today

## Model-Year (Heinrich Siedentopf, astronomer)

Age of the world	:	ca. 5,000,000,000 years
1 year	:	30,000 seconds
in the model-year		1 second = 160 actual years
January (beginning)	:	formations out of gas
January (end)	:	stars (sun)
April	:	solid earth and oceans
July	:	simplest living organism
November (end)	:	vegetations on the land
	:	animals on the land
December 25 <sup>th</sup> and 26 <sup>th</sup>	:	dinosaurs die out
	:	birds and mammals
December 31 <sup>st</sup>		
11 pm	:	First human
11:50 pm	:	Neanderthal man
11:55 pm	:	Homo Sapiens
11:59 pm and 30 seconds	:	beginning of history
11:59 pm and 59 seconds	:	French Revolution

## Time Spans to Next Big Mutation

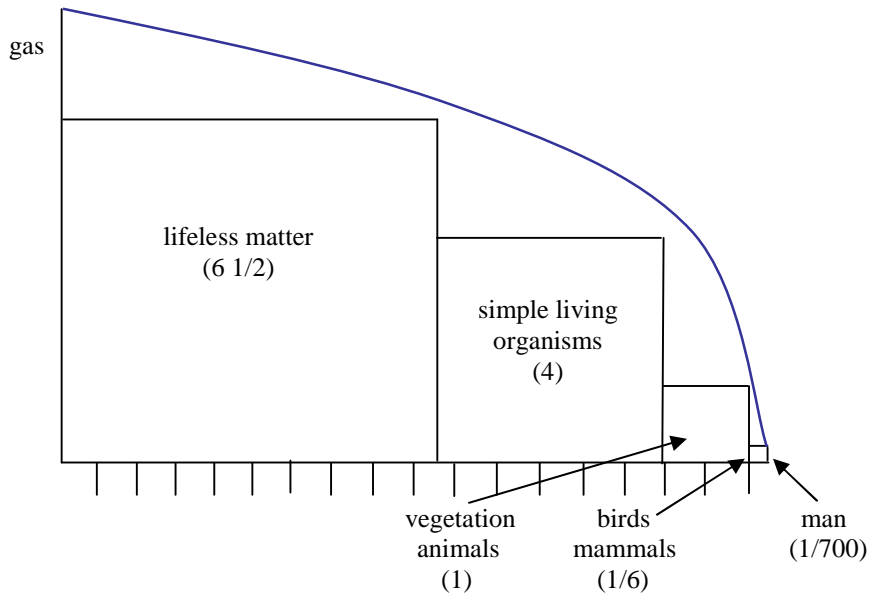

## Population

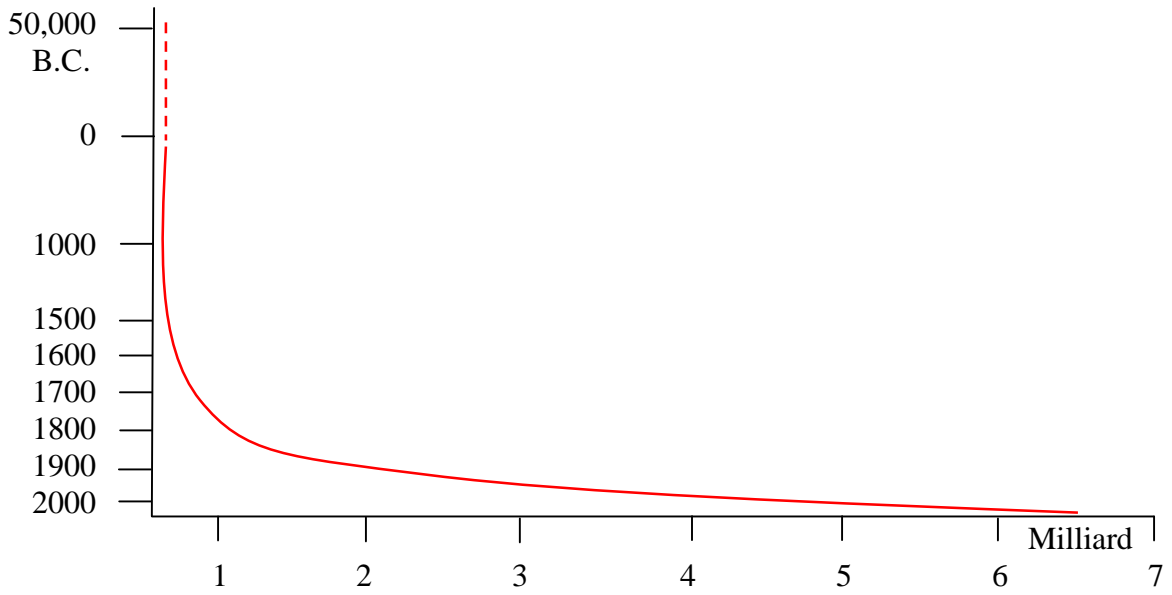

## Average Lifespan

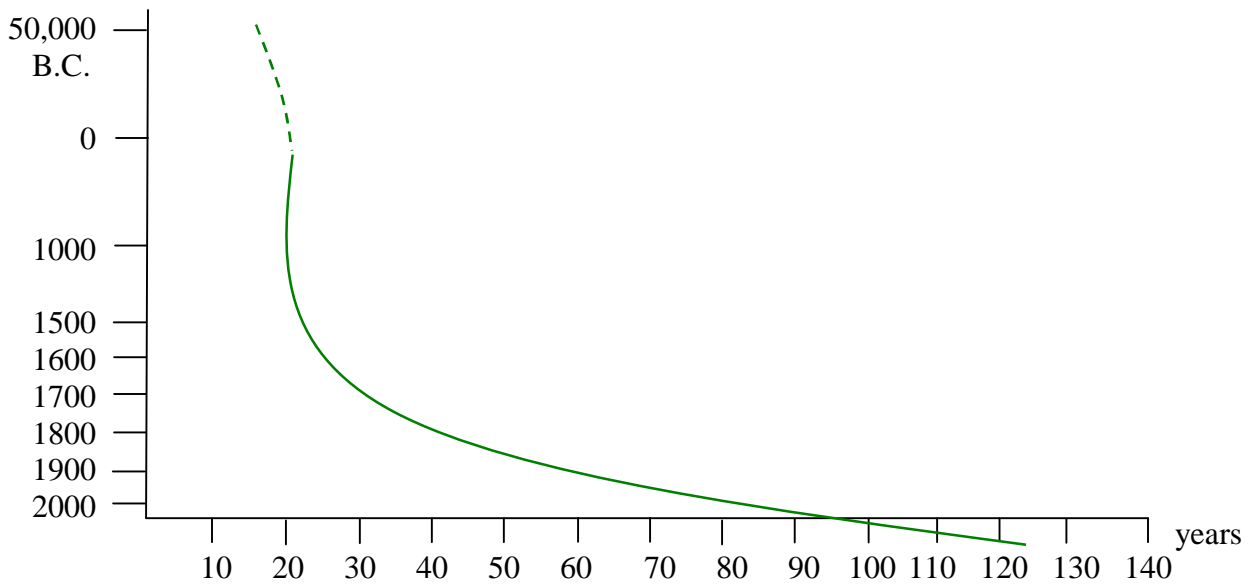

### Total Knowledge

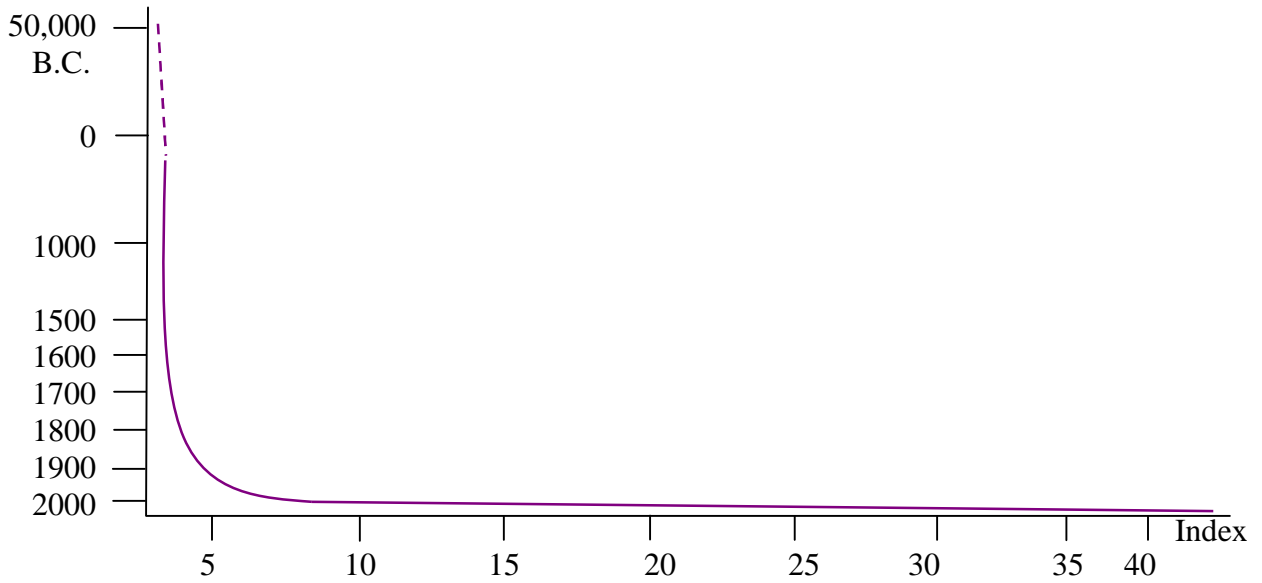

### Total Knowledge Average Lifespan Population Time Spans to Next Big Mutation

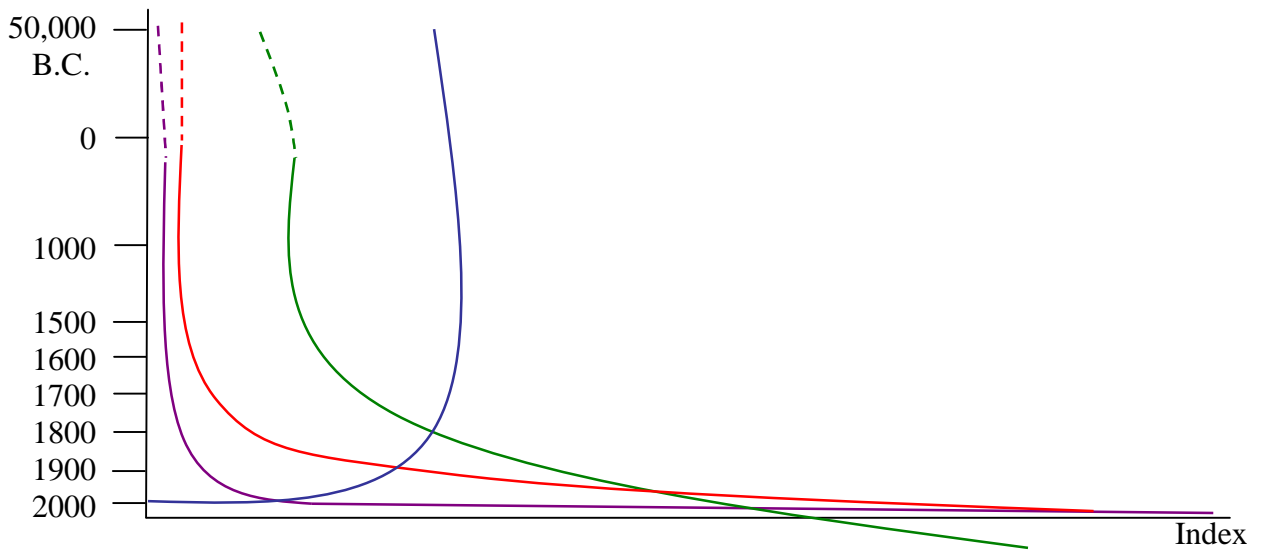

## Scientists

Year	number	Index
1900	15,000	1
1964	2,000,000	140

## Science – Periodicals

Year	number	Index
1800	100	1
1850	1,000	10
1900	10,000	100
1960	100,000	1,000
2000	1,000,000	10,000

## Validity of a world = image

Age	Duration
500 B.C. – 1500 B.C.	1000 years
Since Renaissance	100 years
Today: <ul style="list-style-type: none"> <li>▪ general thought</li> <li>▪ natural scientist</li> </ul>	10 years 5 years



## Vocabulary

– 1550	ca. 1,500 – 5,000
1800 – 1900	ca. 2,000 – 15,000
1900 – 1940	ca. 6,000 – 20,000
1940 – 1970	ca. 10,000 – 100,000

## Communication

Telegraph	1830 – 1967	160,000
Telephone	1900 – 1968	210,000,000
Radio	1920 – 1928	450,000,000
T.V.	1930 – 1968	200,000,000
Newspapers		300,000,000

## The Vertical Breaking into the Horizontal

Subject	horizontal	vertical
EXACT SCIENCES	Scientific methods	intuition
EVOLUTION	causality	mutation
MEDICINE	technical	metaphysical
LAW	natural order	divine order
PHILOSOPHY	human reasoning	sudden enlightenment
LOGIC	dualistic	one-value logic
LANGUAGE	learning	universal grammar
LITERATURE ART	premeditation	sudden inspiration
GENERAL	secular time atomistic	spiritual eternal comprehensive

## Stages of Development of Consciousness

1. Atomistic thinking
2. Linear thinking
3. Functional thinking
4. Operational thinking
5. Structural consciousness
6. Dimensional consciousness
7. Cybernetic consciousness
8. Comprehensive consciousness

### The Infinite

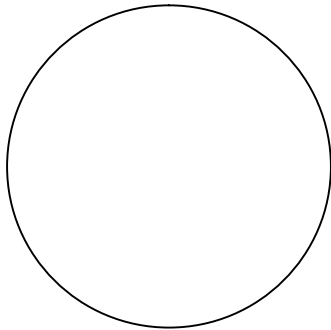

**Mysticism**

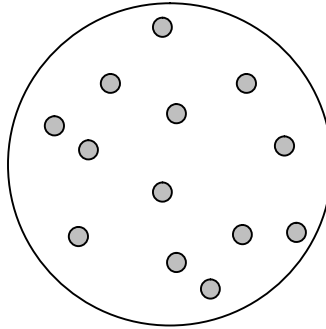

**Religion**

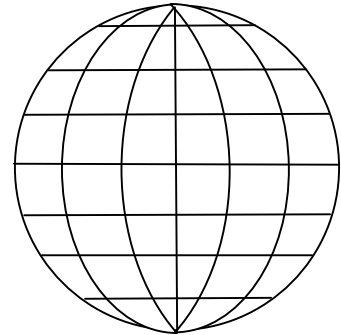

**Science**

<b>4</b>	<b>=</b>	<b>3 + 1</b>
		<b>7 + 3</b>
		<b>2 x 2</b>
		<b>12 ÷ 3</b>
		<b>2<sup>2</sup></b>
		<b>√16</b>
<b>a)</b>	<b>=</b>	<b>categories</b>
		<b>system</b>
<b>b)</b>	<b>=</b>	<b>creative</b>

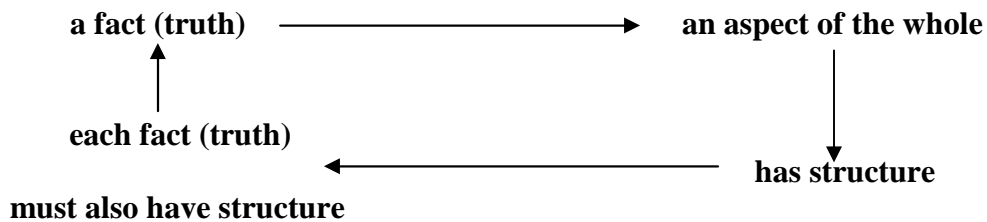

**The numerals of infinity, called seven days**  
(S&H 520:10)

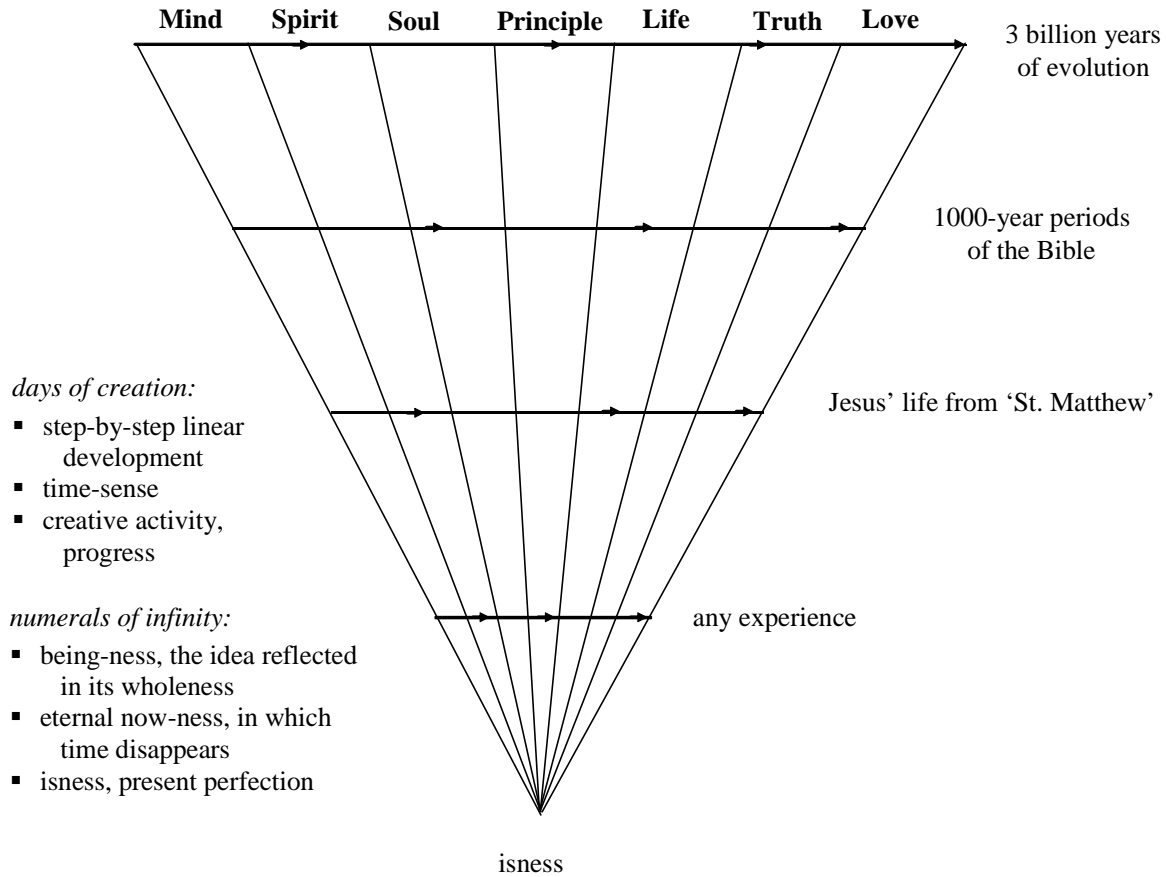

**References:**

**Books by Max Kappeler:**

*Compendium for the Study of Christian Science, No. 2: The Seven Days of Creation*, pp. 33–35.

*The Seven Synonyms for God*, chapter 2: the order of the seven days, also chapter 6: the Word-order.

**Recordings by Max Kappeler:**

A-6III: *Syllabus III*, 1978, Wilmington, DE, hours 8–10, 26–27.

B-2: *The Fundamentals of Christian Science*, 1970, Ogunquit, ME, hours 2–5.

C-1G: *Ch. XV, Genesis, The Structure of the Christian Science Textbook—Our Way of Life*, 1978, hours 13B–14A.

G-2: *The Science of Being—As I See It Today*, 1970, London, England, hours 2B–3.

M-33: *The days of creation and the numerals of infinity*, (4 hours from B-2, #2–5).

**Books by John Doorly:**

*God and Science—Symbols and their importance*, Publisher: London, F. Muller [©1949], statement pp. 15–16, 41–48, Appendix I, pp. 216–218.

*The Pure Science of Christian Science*, pp. 18–19, 47–48.

*Talks on the Science of the Bible*, Vol. I “red-book”, pp. 59–61, 63–65, 80–83, 155–157, 259–260, 272–274.

*Talks on the Science of the Bible*, Vol. II “red-book”, pp. 54–55.

*Talks at the Oxford Summer School, 1948*, Vol. I, p. 20.

*Talks at the Oxford Summer School, 1949*, Vol. II, pp. 136–137, 145–146, 148–151, 156–157.

**Prism and Lens:  
An Explanation of Mary Baker Eddy's Statements**

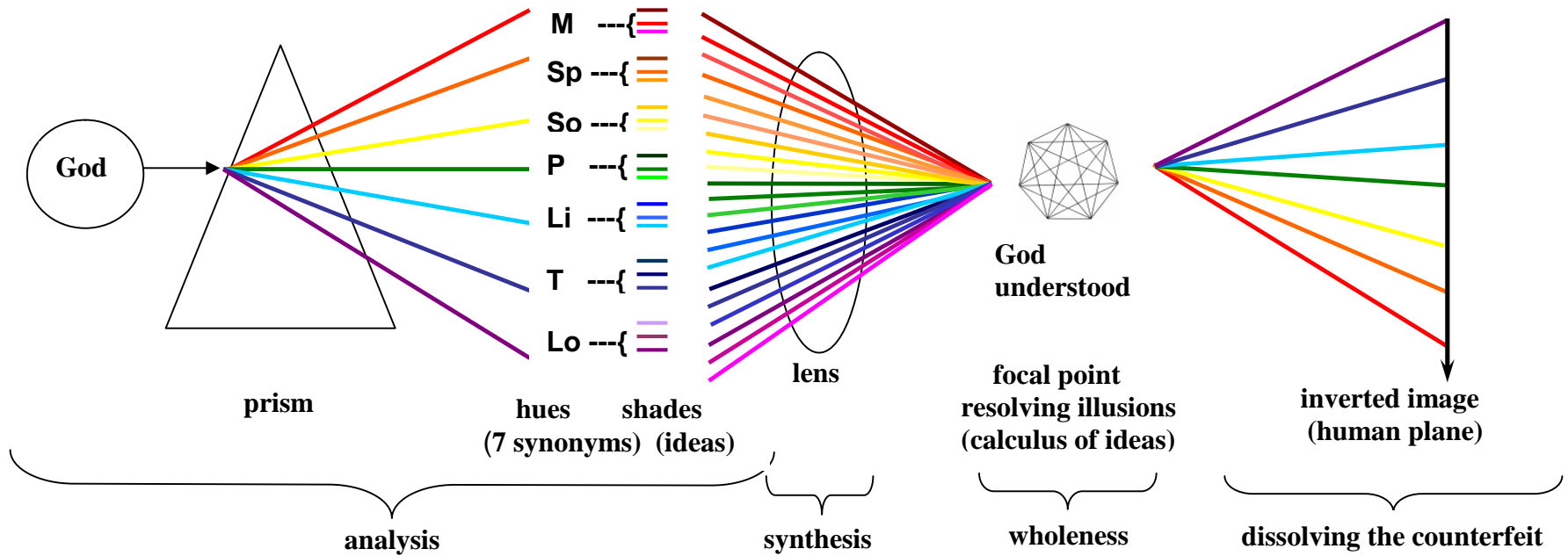

**“Science is the prism of Truth, which divides its rays and brings out the hues of Deity.”**  
 (Ret. 35:13–14)

**“The lens of Science magnifies the divine power to human sight; and we then see the allness of Spirit, therefore the nothingness of matter.”**  
 (’01 12:22–24)

**“The rays of infinite Truth, when gathered into the focus of ideas, bring light instantaneously...”**  
 (S&H 504:23-24)

**“Delusion, sin, disease, and death arise from the false testimony of material sense, which, from a supposed standpoint outside the focal distance of infinite Spirit, presents an inverted image of Mind and substance with everything turned upside down.”**  
 (S&H 301:24–29)

## References for “Prism and Lens”:

### Books by Max Kappeler:

*Introduction to the Science of Christian Science.*

*The Bible in the Light of Christian Science*, Vol. I: Genesis, p. 93.

### Recordings by Max Kappeler:

A-1: *An Introduction to the Science of Christian Science*, 1962, Zürich, Switzerland, hour 3A.

A-4: *The Structure-principle of Being*, 1974, Wilmington, DE, hours 4–6.

B-2: *From Atomistic Thinking to Cybernetic Comprehensive Consciousness*, 1970, Ogunquit, ME, hours 4–5.

D-4: *Divine Cybernetics and the Self-operating “Dimensional Laws” of the One Being: God: Word (Part I), Word (Part II), The Christ (Part III), Christianity (Part IV), Science (Part V)*, 1971/72, New York, hour 2.

G-2: *The Science of Being, as I See it Today*, 1970, London, England, hour 3.

linear



reflection

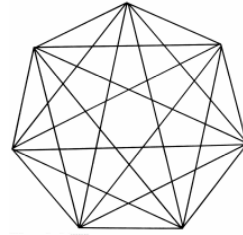

**City foursquare**  
closed system (*S&H* 575: 18-19)

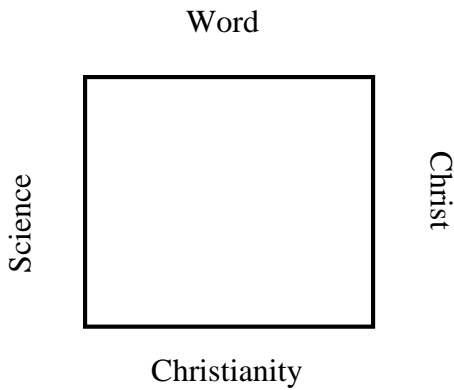

**The city of our God**  
open system (*S&H* 577: 14)

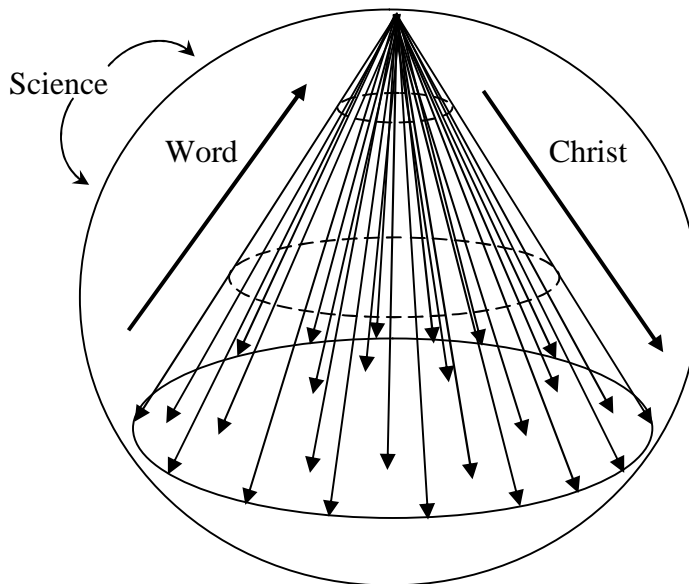
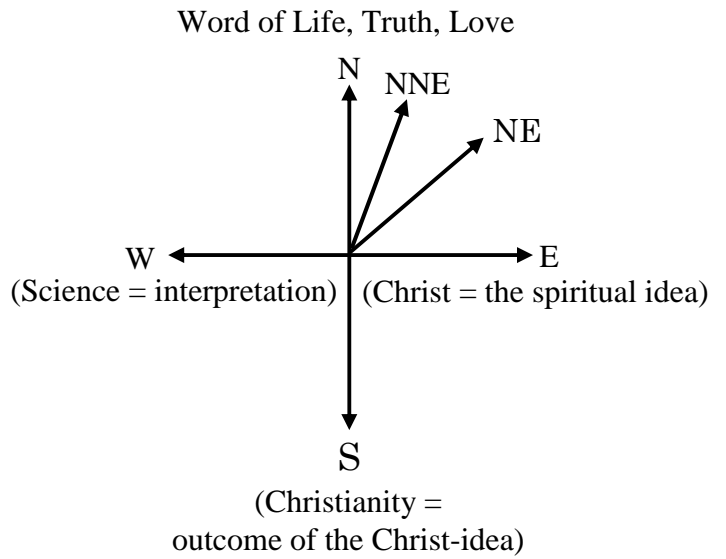



## References for the previous diagram: ‘The four operating as the seven through divine order’

### Books by Max Kappeler:

*The Seven Synonyms for God*, chapter 1, 2, 6.

### Recordings by Max Kappeler:

G-2: *The Science of Being, As I See It Today*, 1970 – London, England, hour 3.

### Books by John Doorly:

*Christian Science Practice*, pp. 31–34, 45.

*The Pure Science of Christian Science*, pp. 49–51.

*Talks at the Oxford Summer School, 1948*, Vol. I, pp. 232–233 (the nature of divine order), also p. 255.

*Talks on the Science of the Bible*, Vol. II “red-book”, pp. 393–394.

*Talks on the Science of the Bible*, Vol. VI “red-book”, pp. 179–180, 205–206.

*Talks on the Science of the Bible*, Vol. IX “red-book”, pp. 112–113 (4 orders), 127.

examples of the four orders:

### ‘Prayer’:

#### Word-order

Books by Max Kappeler:

*The Structure of the Christian Science Textbook*, pp. 10–15

*Epitomes for the Spiritually Structured Interpretation of the Christian Science Textbook*, pp. 2–4

Recording by Max Kappeler:

C-1PR: CH. I, *Prayer, The Structure of the Christian Science Textbook—Our Way of Life*, 27 hours

### Joshua and Judges: each in the Word-order (7 x7)

Book by Max Kappeler:

*The Bible in the Light of Christian Science*, Vol. III: Joshua, Judges

Book by John Doorly:

*Talks on the Science of the Bible*, Vol. IV “red-book”

### I and II Samuel: Word-order

Book by Max Kappeler:

*The Bible in the Light of Christian Science*, Vol. IV: I & II Samuel

Book by John Doorly:

*Talks on the Science of the Bible*, Vol. V “red-book”.

Note: The vast majority of texts in the Bible and in ‘Science and Health with key to the Scriptures’ are laid out in the Word-order, so examples abound.

### II Kings: Christ-order

Book by John Doorly:

*Talks on the Science of the Bible*, Vol. VI “red-book”, pp. 149–293

### Jeremiah: Christ-order

Book by Max Kappeler:

*The Minor Prophets in the Light of Christian Science*, pp. 178–181

Book by John Doorly:

*Talks at the Oxford Summer School, 1948*, Vol. I, pp. 109–256

### Romans: Christ-order

Book by Max Kappeler:

*The Epistles in the Light of Christian Science*. pp. 45–60

Recording by Max Kappeler:

A-6IV: *Syllabus IV*, 1979, Wilmington, DE, hour 11–17

### Isaiah: Word, Christ, Christianity orders

Books by John Doorly:

*Talks on the Science of the Bible*, No. 73 “blue book”, pp. 25–31

*Talks on the Science of the Bible*, No. 74 “blue book”, pp. 1–21

### Daniel: Word Christ, Christianity, and Science orders

Book by Max Kappeler:

*The Minor Prophets in the Light of Christian Science*, pp. 185–188

Book by John Doorly:

*Talks on the Science of the Bible*, Vol. IX “red-book”, pp. 157–188 (in full, pp. 15–188)

### Zechariah: Word, Christ, Christianity, and Science orders

Book by Max Kappeler:

*The Minor Prophets in the Light of Christian Science*, pp. 140–159

Book by John Doorly:

*Talks on the Science of the Bible*, Vol. IX “red-book”, pp. 314–386

### I John: Word, Christ, Christianity, and Science orders

Book by Max Kappeler:

*The Epistles in the Light of Christian Science*. pp. 212–22

The Science of Being—As I See It Today, Tape code G-2

©1970, 2006 Kappeler Institute for the Science of Being, PO Box 99735, Seattle, WA 98139-0735. All rights reserved.



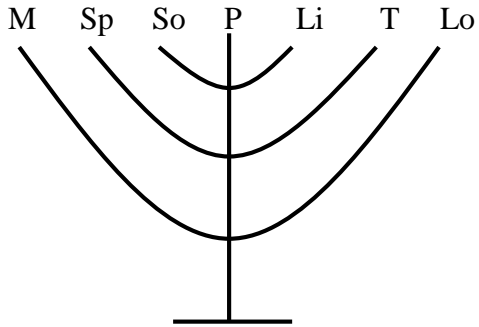

**candlestick**

---

linear	2	4	6	8	10	12	14
exponential	2	4	8	16	32	64	128

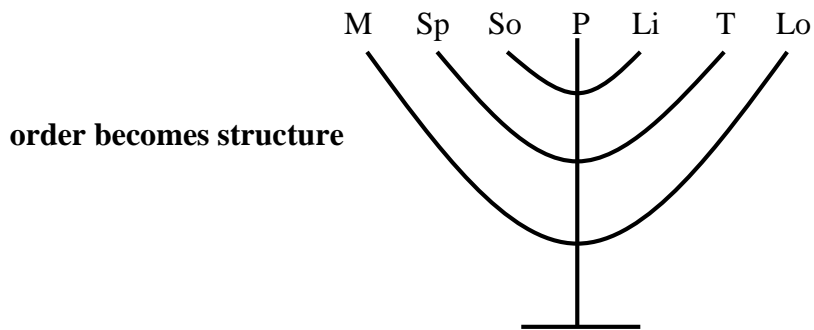
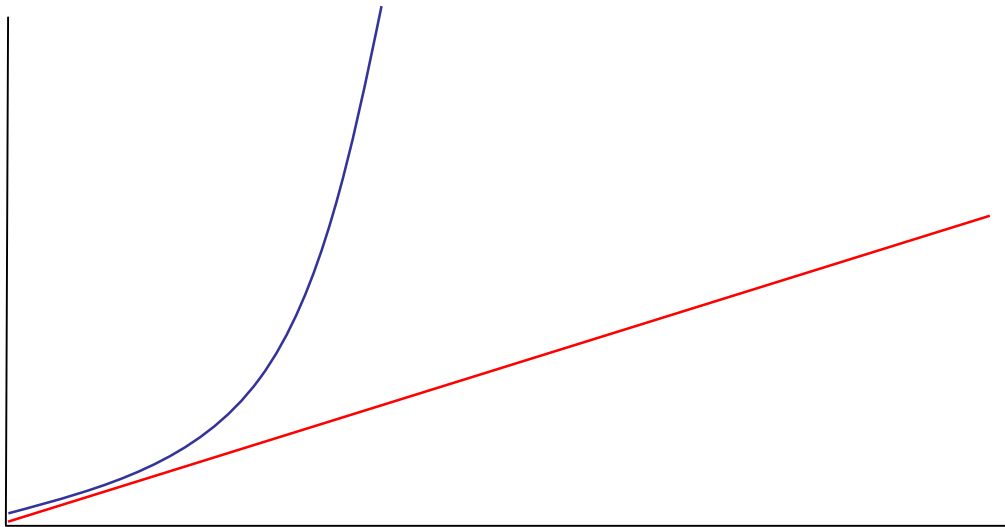

### structural consciousness (Gauss)

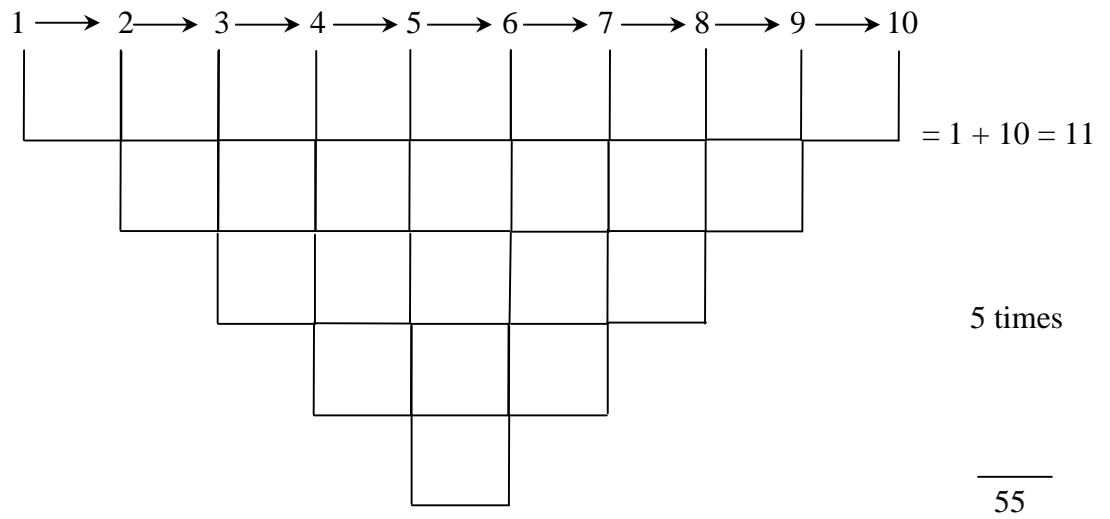

$$1 + \dots + 100 = 101$$

$\frac{100}{2} = 50$

$\times$

$\frac{50}{5050}$

## Structure

<i>structura</i>	=	to arrange; to fit together (system = to place together)
structure	=	the interrelationships of parts as dominated by the general character of the whole. (Webster)
	=	the sum total of relationships which maintains the communication between the different parts of the whole. (Prof. Amar)

## Attitude

### *Structural*

has the whole in view  
considers structure  
always has a new perspective  
center: the whole  
the whole has its own solution

### *atomistic*

narrow-mindedness  
engulfed in details  
pedantic  
routine  
repetitive  
center: personal "I"  
meets our own desires

## New Mathematics

0	1	2	3	4	5	6	7	8	9
10	11	12	13	14	15	16	17	18	19
20	21	22	23	24	25	26	27	28	29
30	31	32	33	34	35	36	37	38	39
40	41	42	43	44	45	46	47	48	49
50	51	52	53	54	55	56	57	58	59
60	61	62	63	64	65	66	67	68	69
70	71	72	73	74	75	76	77	78	79
80	81	82	83	84	85	86	87	88	89
90	91	92	93	94	95	96	97	98	99

0					5				
10					15				
20					25				
30					35				
40					45				
50					55				
60					65				
70					75				
80					85				
90					95				

0			3			6			9
		14			15			18	
	21			24			27		
30			33			36			39
		42			45			48	
	51			54			57		
60			63			66			69
		72			75			78	
	81			84			87		
90			93			96			99

0						6			
	12							18	
			24						
30					36				
	42							48	
			54						
60					66				
	72							78	
			84						
90					96				

### Kékulé (benzene ring)

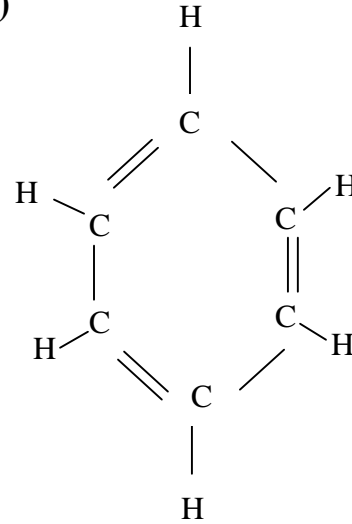
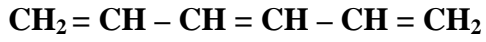

### Synonyms-Matrix

SYNONYM	MIND	SPIRIT	SOUL	PRINCIPLE	LIFE	TRUTH	LOVE
Mind	M	Sp	So	P	Li	T	Lo
	M	M	M	M	M	M	M
Spirit	M	Sp	So	P	Li	T	Lo
	Sp	Sp	Sp	Sp	Sp	Sp	Sp
Soul	M	Sp	So	P	Li	T	Lo
	So	So	So	So	So	So	So
Principle	M	Sp	So	P	Li	T	Lo
	P	P	P	P	P	P	P
Life	M	Sp	So	P	Li	T	Lo
	Li	Li	Li	Li	Li	Li	Li
Truth	M	Sp	So	P	Li	T	Lo
	T	T	T	T	T	T	T
Love	M	Sp	So	P	Li	T	Lo
	Lo	Lo	Lo	Lo	Lo	Lo	Lo

## Calculus-matrix

CALCULUS	WORD	CHRIST	CHRISTIANITY	SCIENCE
Word	W/W	X/W	Xty/W	Sc/W
Christ	W/X	X/X	Xty/X	Sc/X
Christianity	W/Xty	X/Xty	Xty/Xty	Sc/Xty
Science	W/Sc	X/Sc	Xty/Sc	Sc/Sc

## Prophets

CALCULUS	WORD	CHRIST	CHRISTIANITY	SCIENCE
Word	W/W	X/W	Xty/W	Sc/W
Christ	W/X	X/X	Xty/X	Sc/X
Christianity	W/Xty	X/Xty	Xty/Xty	Sc/Xty
Science	W/Sc	X/Sc	Xty/Sc	Sc/Sc

## MIND-matrix

MIND	WORD	CHRIST	CHRISTIANITY	SCIENCE
Word	1.	5.	9.	13.
Christ	2.	6.	10.	14.
Christianity	3.	7.	11.	15.
Science	4.	8.	12.	16.

MIND	WORD <i>MIND is ALL</i>	CHRIST <i>The POWER of MIND</i>	CHRISTIANITY <i>The allness of MIND</i>	SCIENCE <i>MIND and MIND's idea is one</i>
Word	1.	5.	9.	13.
Christ	2.	6.	10.	14.
Christianity	3.	7.	11.	15.
Science	4.	8.	12.	16.

## Evil-matrix

EVIL	WORD	CHRIST	CHRISTIANITY	SCIENCE
Word	1.	5.	9.	13.
Christ	2.	6.	10.	14.
Christianity	3.	7.	11.	15.
Science	4.	8.	12.	16.

EVIL	WORD <i>to free ourselves from evil</i>	CHRIST <i>Evil has no power</i>	CHRISTIANITY <i>Superiority of good over evil</i>	SCIENCE <i>Providing good = disproving evil</i>
Word	1.	5.	9.	13.
Christ	2.	6.	10.	14.
Christianity	3.	7.	11.	15.
Science	4.	8.	12.	16.



# Calculus-matrices

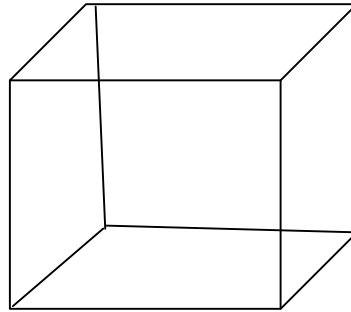

WORD

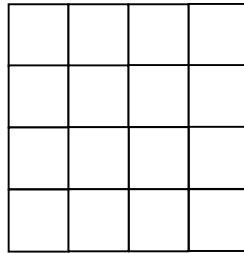

SCIENCE

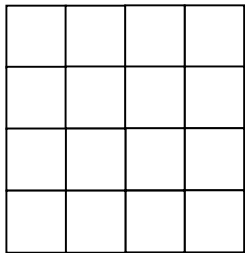

↑  
W

CHRIST

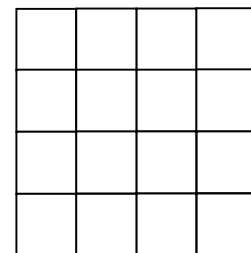

← Sc

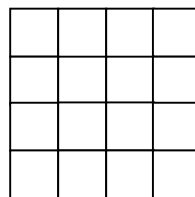

X →

Xty

↓

CHRISTIANITY

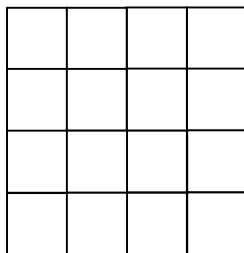

## WORD-matrix

WORD	WORD	CHRIST	CHRISTIANITY	SCIENCE
Word	1.	5.	9.	13.
Christ	2.	6.	10.	14.
Christianity	3.	7.	11.	15.
Science	4.	8.	12.	16.

## CHRIST-matrix

CHRIST	WORD	CHRIST	CHRISTIANITY	SCIENCE
Word	1.	5.	9.	13.
Christ	2.	6.	10.	14.
Christianity	3.	7.	11.	15.
Science	4.	8.	12.	16.

CHRIST	WORD <i>Mono- potency of good</i>	CHRIST <i>Reforming power</i>	CHRISTIANITY <i>Restoration of the idea</i>	SCIENCE <i>Operation of idea in its Principle</i>
Word <i>divine purpose defined</i>	1.	5.	9.	13.
Christ <i>Translation of two-ness into one-ness</i>	2.	6.	10.	14.
Christianity <i>Evil disappears Good appears</i>	3.	7.	11.	15.
Science <i>understanding</i>	4.	8.	12.	16.

## CHRISTIANITY-matrix

CHRISTIANITY	WORD	CHRIST	CHRISTIANITY	SCIENCE
Word	1.	5.	9.	13.
Christ	2.	6.	10.	14.
Christianity	3.	7.	11.	15.
Science	4.	8.	12.	16.

CHRISTIANITY	WORD <i>The grace of God</i>	CHRIST <i>The glory of Christ</i>	CHRISTIANITY <i>Man's perfection</i>	SCIENCE <i>The Science of man</i>
Word <i>accepting</i>	1.	5.	9.	13.
Christ <i>claiming</i>	2.	6.	10.	14.
Christianity <i>abiding</i>	3.	7.	11.	15.
Science <i>proving by living</i>	4.	8.	12.	16.

**DIMENSIONALISM**  
(against reductionism)

Diagram A

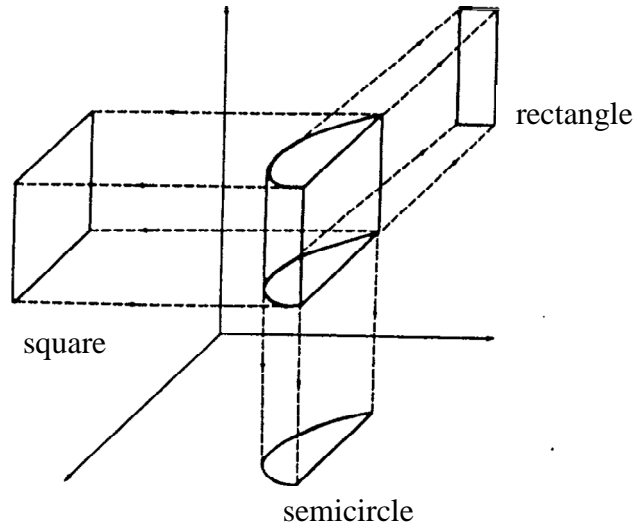

Diagram B

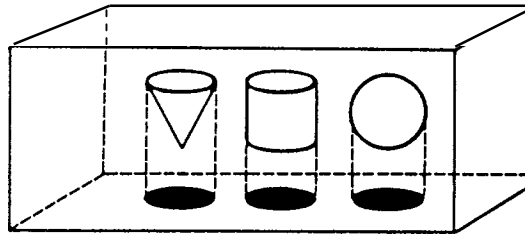
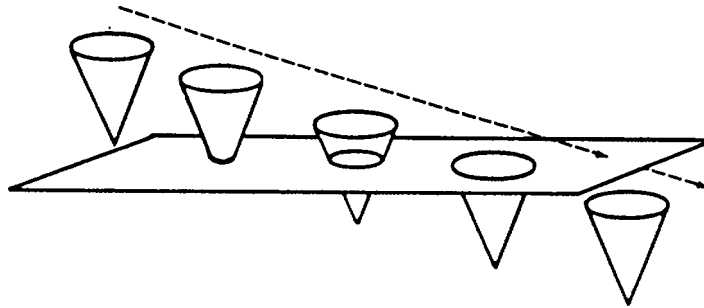

Diagram C



**References:**

**Recordings by Max Kappeler:**

A-4: *The Structure-principle of Being*, 1974, Wilmington, DE, hour 20.  
A-6V: *Syllabus V*, 1980, hour 3.

B-2: *From Atomistic Thinking to Cybernetic Comprehensive Consciousness*, 1970, Ogunquit, ME, hour 17.

D-4: *Divine Cybernetics and the Self-operating "Dimensional Laws" of the One Being: God*, 1971/72, New York, hour 3.

G-2: *The Science of Being—As I See It Today*, 1970, London, England, hours 6–7.

**Books by Max Kappeler:**

*The Seven Synonyms for God*, Chapter 7.

*The Science of the Oneness of Being in the Christian Science Textbook*, pp. 49–51.

The Science of Being—As I See It Today, Tape code G-2

©1970, 2006 Kappeler Institute for the Science of Being, PO Box 99735, Seattle, WA 98139-0735. All rights reserved.

## The Chart

### 1<sup>st</sup> category

WORD	CHRIST	CHRISTIANITY	SCIENCE

### 2<sup>nd</sup> category

Science	Principle itself	One
Divine Science	Principle and idea = One	oneness
absolute Christian Science	Relationship of Principle to ideas	unity
Christian Science	ideas versus illusions	makes one

## The Chart

combining 1<sup>st</sup> and 2<sup>nd</sup> categories

Science				
	WORD	CHRIST	CHRISTIANITY	SCIENCE
Divine Science				
absolute Christian Science				
Christian Science				

Science	Principle																		
	WORD	CHRIST	CHRISTIANITY	SCIENCE															
Divine Science	Li	T	Lo	divine Principle, Love															
absolute Christian Science	Li T Lo	T Li Lo	Li Lo	T Lo															
Christian Science	M Sp So P Li T Lo	P Li T Lo So Sp M	P M So Sp Li T Lo	<table style="margin: auto; border: none;"> <tr> <td></td> <td style="text-align: center;">P</td> <td></td> </tr> <tr> <td style="text-align: center;">So</td> <td style="text-align: center;">⋮</td> <td style="text-align: center;">Li</td> </tr> <tr> <td style="text-align: center;">Sp</td> <td style="text-align: center;">⋮</td> <td style="text-align: center;">T</td> </tr> <tr> <td style="text-align: center;">M</td> <td style="text-align: center;">⋮</td> <td style="text-align: center;">Lo</td> </tr> <tr> <td></td> <td style="text-align: center;">P</td> <td></td> </tr> </table>		P		So	⋮	Li	Sp	⋮	T	M	⋮	Lo		P	
	P																		
So	⋮	Li																	
Sp	⋮	T																	
M	⋮	Lo																	
	P																		

## Platform

PLATFORM	WORD	CHRIST	CHRISTIANITY	SCIENCE
Word	1	9	17	25
	2	10	18	26
Christ	3	11	19	27
	4	12	20	28
Christianity	5	13	21	29
	6	14	22	30
Science	7	15	23	31
	8	16	24	32

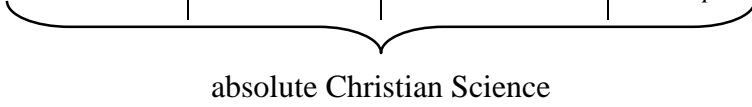

## CHRIST-matrix (Prophets)

CHRIST	WORD  <i>Mono-potency of good</i>	CHRIST  <i>Reforming power</i>	CHRISTIANITY  <i>Restoration of the idea</i>	SCIENCE  <i>Operation of idea in its Principle</i>
	 absolute Christian Science			
<b>Word</b>  <i>Divine purpose defined</i>	1.	5.	9.	13.
<b>Christ</b>  <i>Translation of two-ness into one-ness</i>	2.	6.	10.	14.
<b>Christianity</b>  <i>Evil disappears Good appears</i>	3.	7.	11.	15.
<b>Science</b>  <i>Understanding</i>	4.	8.	12.	16.

## CHRISTIANITY-matrix (Epistles)

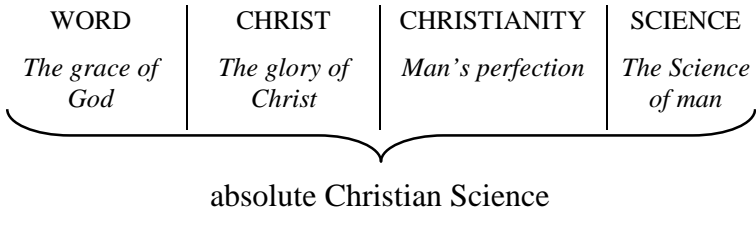
CHRISTIANITY	WORD <i>The grace of God</i>	CHRIST <i>The glory of Christ</i>	CHRISTIANITY <i>Man's perfection</i>	SCIENCE <i>The Science of man</i>
	 absolute Christian Science			
Word <i>accepting</i>	1.	5.	9.	13.
Christ <i>Translation of claiming</i>	2.	6.	10.	14.
Christianity <i>abiding</i>	3.	7.	11.	15.
Science <i>proving by living</i>	4.	8.	12.	16.

## The Law of Gravitation

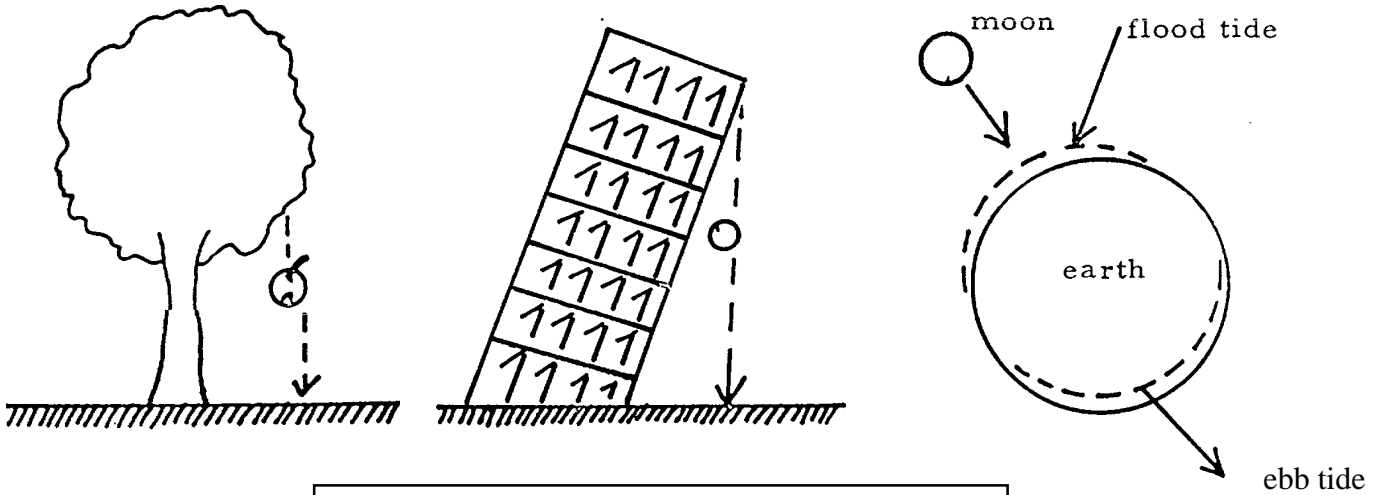

law:

$$F = g \frac{m_1 \cdot m_2}{r^2}$$

## The Law of Interdependence

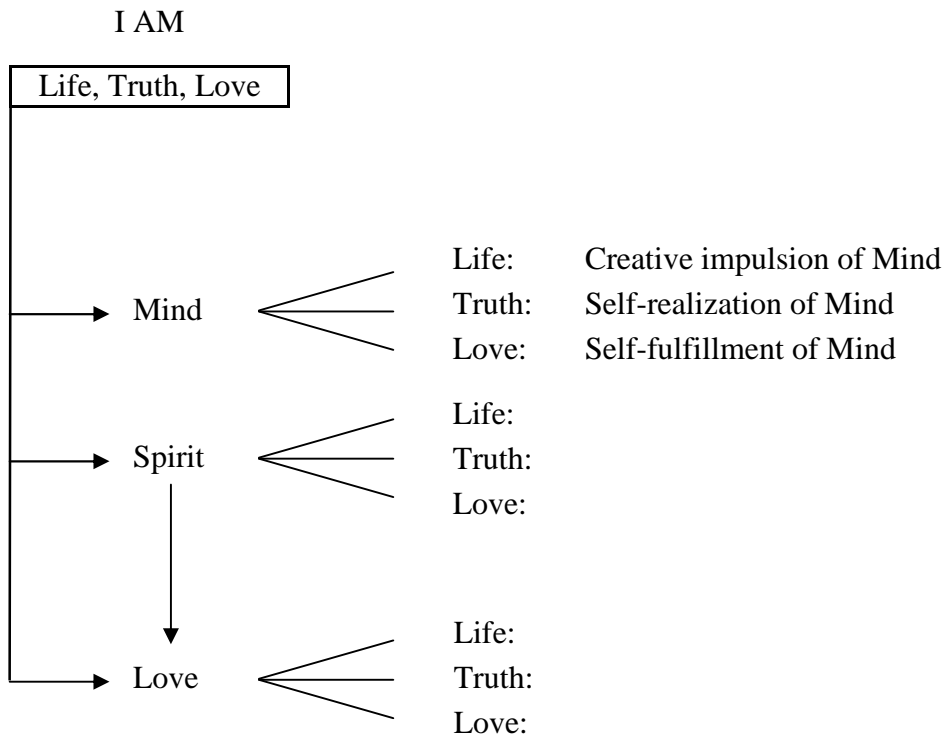

## Examples of Dimensionalism

Sciences (Müller-Markus)	4. noosphere 3. psychosphere 2. biosphere 1. cosmosphere
Psychology	4. super-conscious 3. unconscious 2. subconscious 1. humanly conscious
Psychedelic (Masters & Houston)	4. integral level 3. symbolic level 2. memorial-analytical level 1. sensoric level
T. de Chardin	4. Christo genesis 3. noogenesis 2. biogenesis 1. cosmogenesis
Philosophy (N. Hartmann)	4. Spirit 3. Soul and its phenomena 2. living things 1. objects and physical process

## Divine Cybernetics

homeostasis:	<i>homeo</i> = equal <i>stasis</i> = static
homeorhese:	<i>homeo</i> = equal <i>rhese</i> = flowing

## Divine Cybernetic Model

Science itself				
	Word	Christ	Christianity	Science
divine Science	input	process	output	feedback
	self-organizing			
absolute Christian Science	positive feedback			
Christian Science	negative feedback			

### divine cybernetics presents:

- |                                  |   |
|----------------------------------|---|
| Science itself                   | the one infinite Being  |
| divine Science                   | as a self-organizing system,<br>running on a self-regulating<br>circuit |
| absolute<br>Christian<br>Science | that has positive feedback<br>(is error-preventing)                     |
| Christian Science                | as well as negative feedback<br>(is error-correcting)                   |

### Logicity of Science

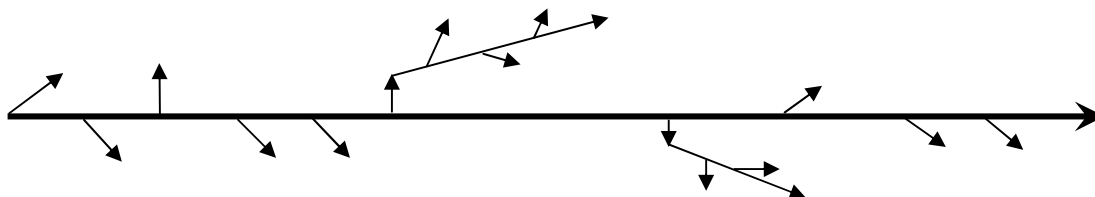

The Science of Being—As I See It Today, Tape code G-2  
 ©1970, 2006 Kappeler Institute for the Science of Being, PO Box 99735, Seattle, WA 98139-0735. All rights reserved.

## The Theory of Evolution (Prof. Eigen, 1970)

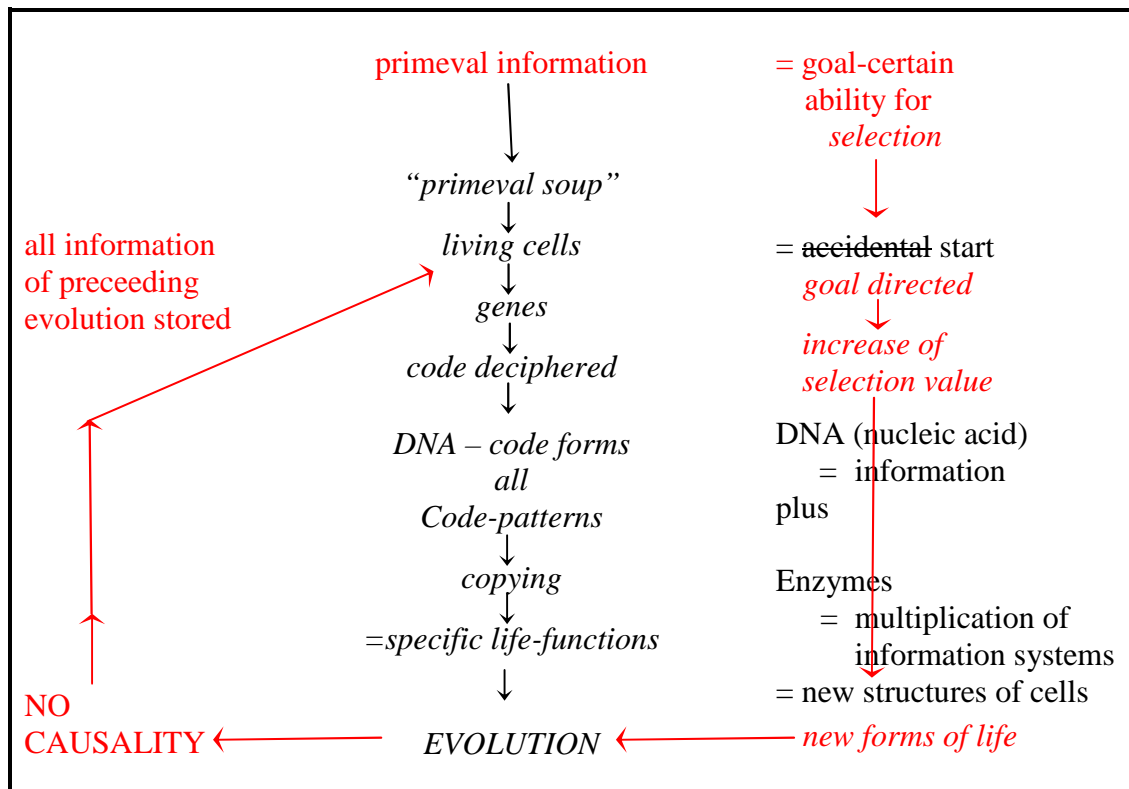
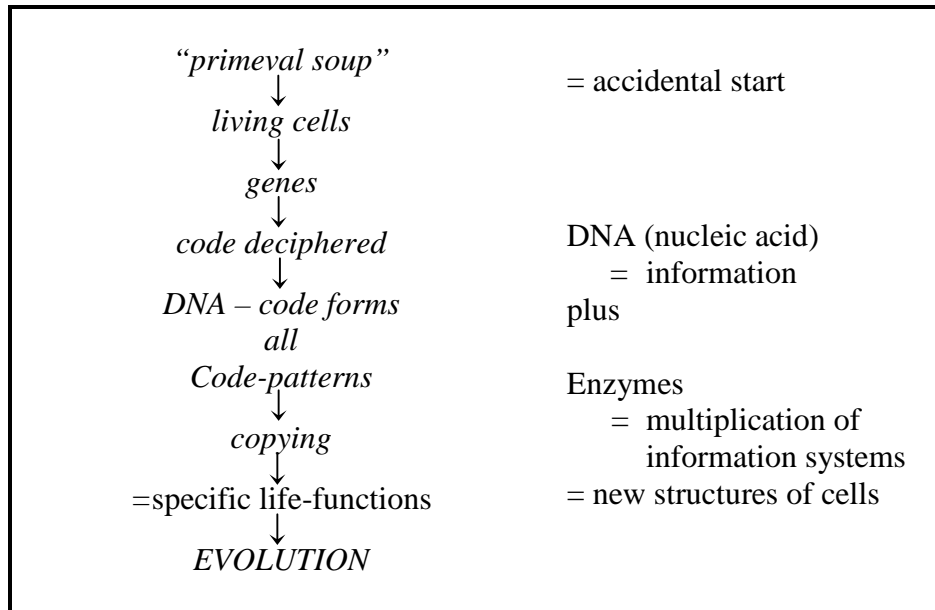

## The Theory of Evolution (Prof. Eigen, 1970)

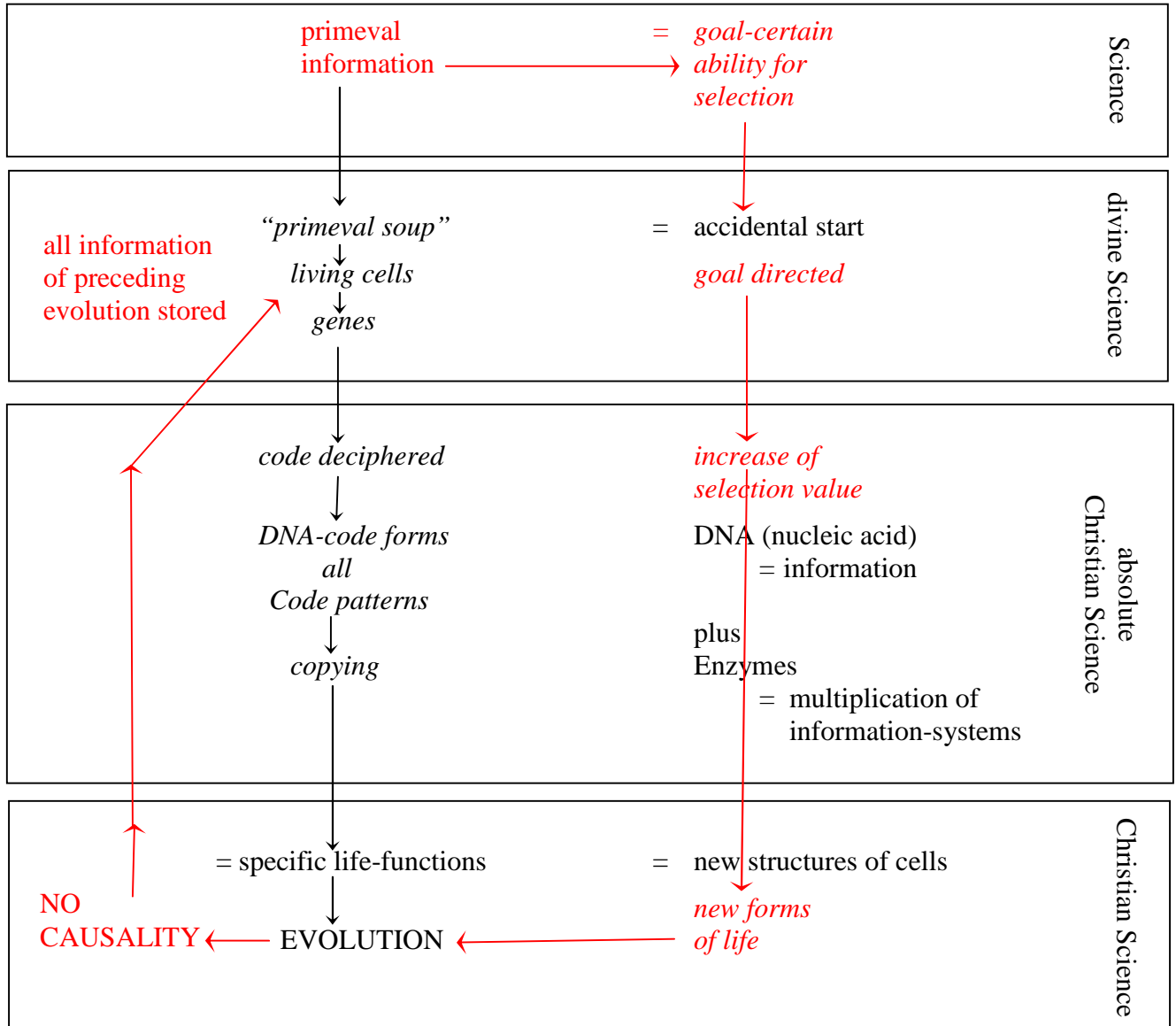

## Mother – Church

