



**KAPPELER INSTITUTE RECORDINGS**

## **ILLUSTRATIVE MATERIAL**

### **THE G-SERIES\***

includes Illustrative Material for:

G-2 The Science of Being—As I See It Today

G-3 The Model of Being and its Universal Laws

G-7 The Law of the Self-evolution of Understanding  
Through the Idea of Christian Science

**MAX KAPPELER**

\*Audio Codes for this set: G-2, G-3, G-7





**KAPPELER INSTITUTE RECORDINGS**

**ILLUSTRATIVE MATERIAL**

**THE SCIENCE OF BEING—  
AS I SEE IT TODAY**

**(Tape Code G-2)**

**Max Kappeler**

©1970, 2006, Kappeler Institute for the Science of Being  
All rights reserved



Kappeler Institute Publishing  
P.O. Box 99735  
Seattle, WA 98139-0735  
Tel: (206) 286-1617 • Fax: (206) 286-1675  
E-mail: [mail@kappelerinstitute.org](mailto:mail@kappelerinstitute.org)  
[www.kappelerinstitute.org](http://www.kappelerinstitute.org)  
Division of Kappeler Institute for the Science of Being, USA  
Seattle, WA USA

# Contents

## The Science of Being— As I See It Today

(Tape code: G-2)

©1970, 2006 Kappeler Institute for the Science of Being

AUDIO RECORDING NUMBER/SIDE	SUBJECT
1-A	Introduction
1-B	The spiritual idea impelling the acceleration of mutations <ul style="list-style-type: none"><li>♦ examples: population explosion, increased life-span, total knowledge, scientists, science periodicals, validity of world-image; vocabulary, intensification of consciousness, growth in energy available</li><li>♦ the vertical (exponential growth) is the sign of the spiritual, breaking through the horizontal way of thinking.</li></ul>
2-A	Stages in the development of consciousness
2-B	1. Atomistic thinking ...continued
3-A	2. linear-rational thinking
3-B	– order; sequences: <ul style="list-style-type: none"><li>• the evolution of life</li><li>• the 1000-year periods in the Bible</li><li>• the law of creativity</li></ul>
3-B	3. functional thinking
4-A	– the blending or calculus of ideas
4-A	4. operational thinking Word (W), Christ (X), Christianity (Xty), Science (Sc)
4-B	5. structural consciousness
5-A	– a simplifying process
5-B	– classical logical thinking versus structural consciousness
6-A	– definitions of structure
6-A	...continued
6-A	♦ review of the modes of thinking leading to structuralism
6-A	– examples of structural thinking in the world
6-A	– development of structural thinking in Christian Science
6-A	• examples: matrices: 4x4 calculus, prophets-matrix, epistles matrix, synonym- matrices, the matrix of handling evil, Word-matrix, Christ and Christianity matrices

6-B	6. dimensional consciousness ...continued
	– dimensional thinking in the world
7-A	...continued
	– dimensionalism in Christian Science: Sc, dSC, aCS, CS
	– each level alone leads to reductionism
	– the vertical laws
	• example: the “Platform”-matrix: W, X, Xty, Sc/aCS/CS
7-B	– intertwining the fourfold operation with the four levels brings out the laws of Being
	– dimensionalism in the sciences and in philosophy
	7. cybernetic consciousness
8-A	...continued
	– the idea of divine cybernetics as a self-organizing, self-regulating system
8-B	...continued
	8. comprehensive consciousness

---



---

ABBREVIATIONS

M, Sp, So, P, Li, T, Lo	= Mind, Spirit, Soul, Principle, Life, Truth, Love
W, X, Xty, Sc	= Word, Christ, Christianity, Science
Sc, dSc, aCS, CS	= Science, divine Science, absolute Christian Science, Christian Science
I.M.	= Illustrative Material
S.A.	= <i>A Study Aid for the Science of Christian Science</i> , by Max Kappeler
S&H	= <i>Science and Health with Key to the Scriptures</i> , by Mary Baker Eddy
M/M–M/Lo	= Mind as Mind through the 7 synonyms to Mind as Love
Mis.	= <i>Miscellaneous Writings</i> , by Mary Baker Eddy

# The Science of Being—As I See It Today

## Model-Year (Heinrich Siedentopf, astronomer)

Age of the world	:	ca. 5,000,000,000 years
1 year	:	30,000 seconds
in the model-year		1 second = 160 actual years
January (beginning)	:	formations out of gas
January (end)	:	stars (sun)
April	:	solid earth and oceans
July	:	simplest living organism
November (end)	:	vegetations on the land
	:	animals on the land
December 25 <sup>th</sup> and 26 <sup>th</sup>	:	dinosaurs die out
	:	birds and mammals
December 31 <sup>st</sup>		
11 pm	:	First human
11:50 pm	:	Neanderthal man
11:55 pm	:	Homo Sapiens
11:59 pm and 30 seconds	:	beginning of history
11:59 pm and 59 seconds	:	French Revolution

## Time Spans to Next Big Mutation

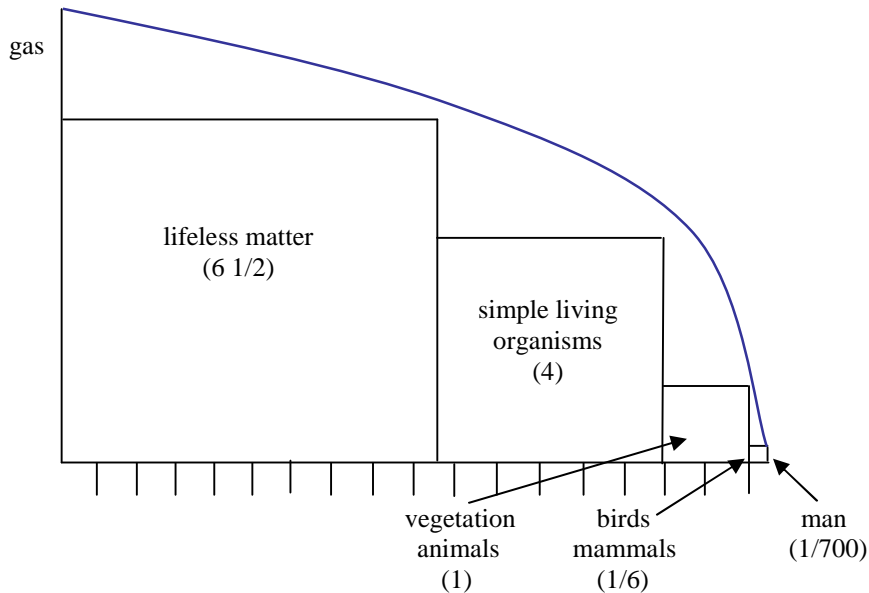

## Population

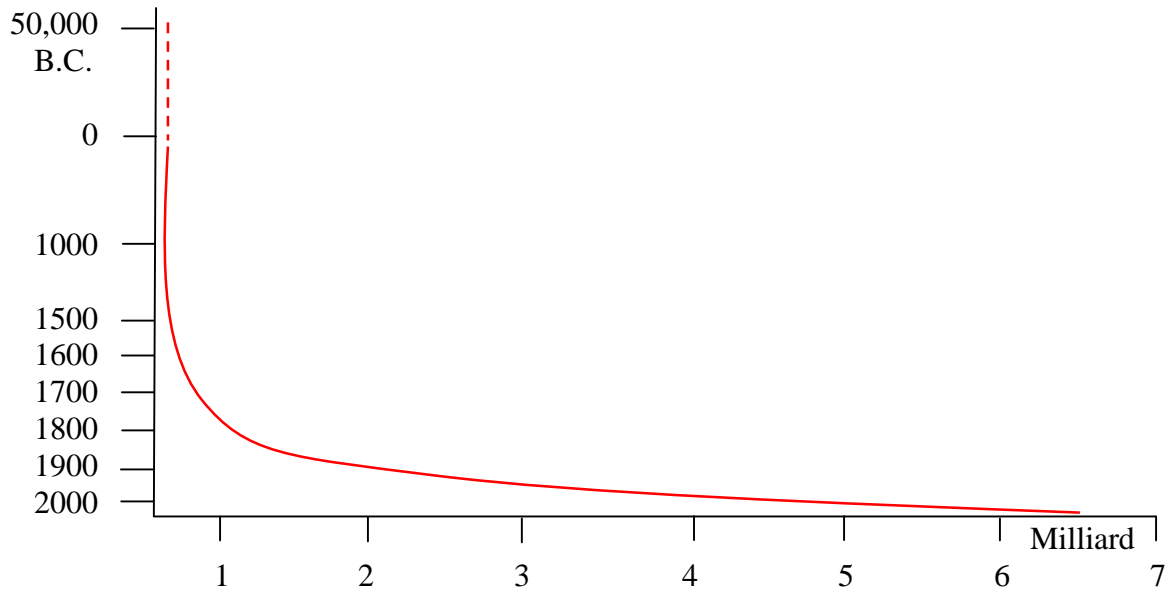

## Average Lifespan

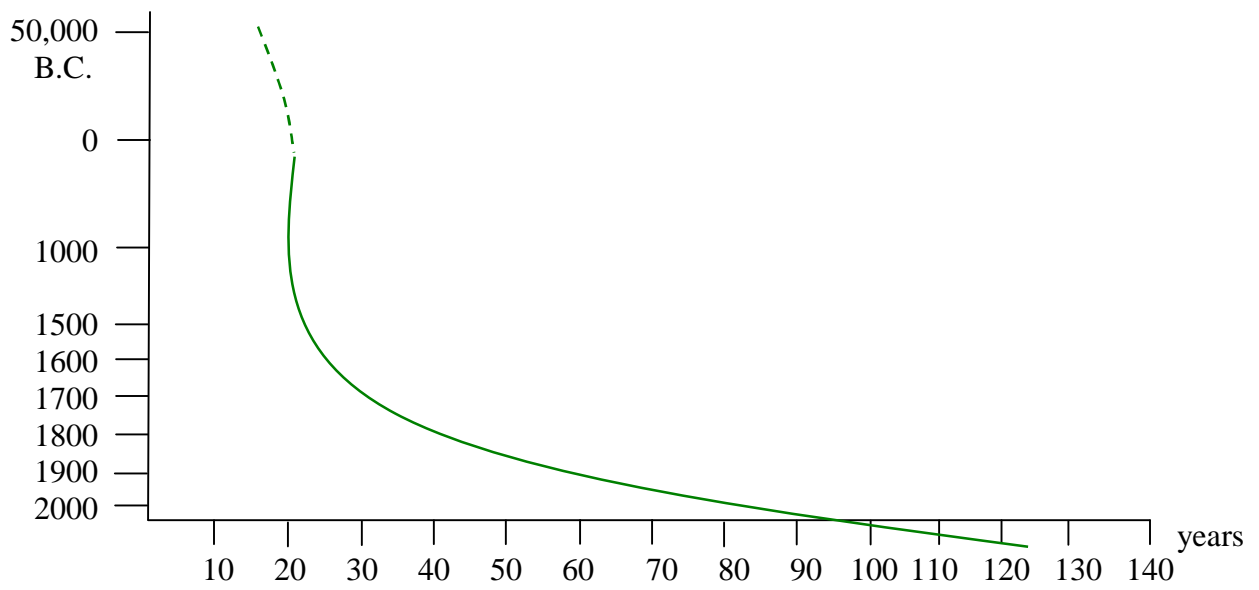



### Total Knowledge

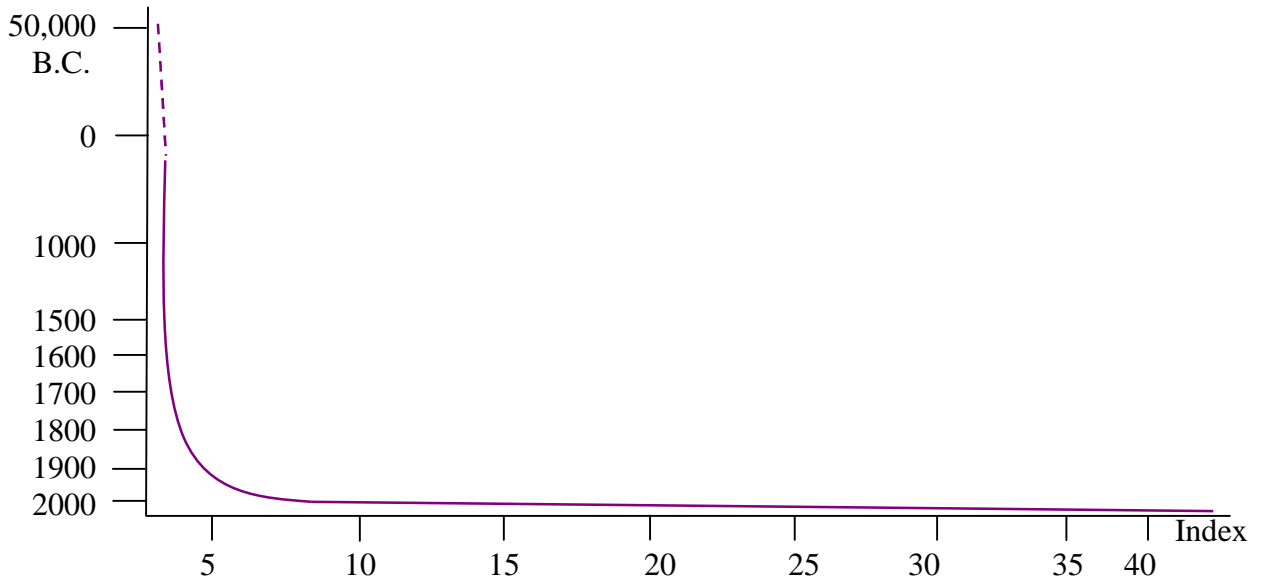

### Total Knowledge Average Lifespan Population Time Spans to Next Big Mutation

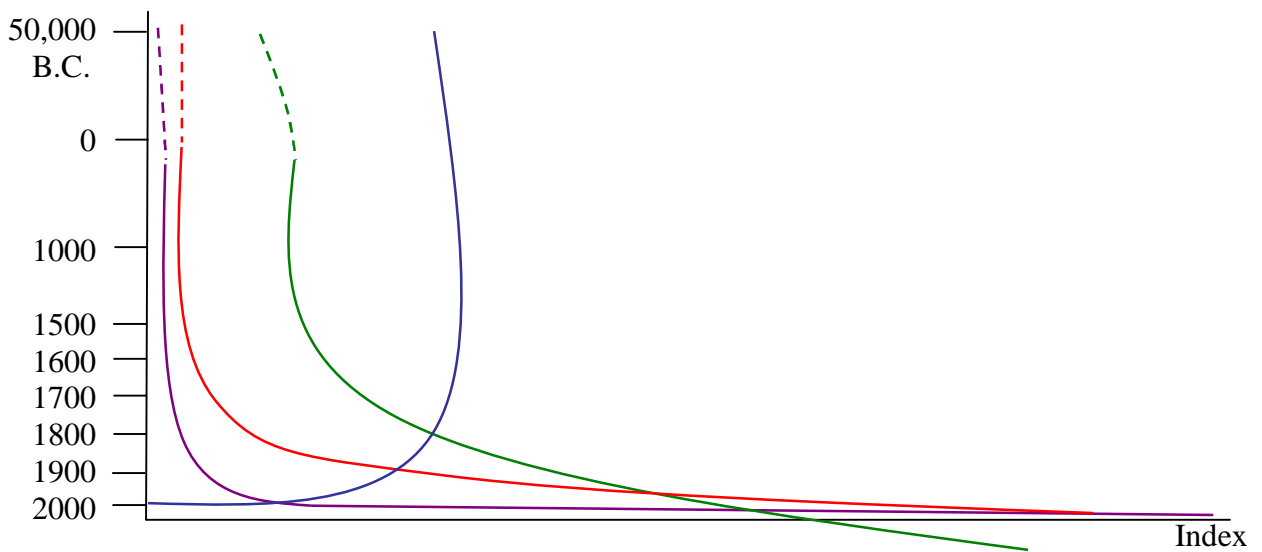

## Scientists

Year	number	Index
1900	15,000	1
1964	2,000,000	140

## Science – Periodicals

Year	number	Index
1800	100	1
1850	1,000	10
1900	10,000	100
1960	100,000	1,000
2000	1,000,000	10,000

## Validity of a world = image

Age	Duration
500 B.C. – 1500 B.C.	1000 years
Since Renaissance	100 years
Today:	
▪ general thought	10 years
▪ natural scientist	5 years

## Vocabulary

– 1550	ca. 1,500 – 5,000
1800 – 1900	ca. 2,000 – 15,000
1900 – 1940	ca. 6,000 – 20,000
1940 – 1970	ca. 10,000 – 100,000

## Communication

Telegraph	1830 – 1967	160,000
Telephone	1900 – 1968	210,000,000
Radio	1920 – 1928	450,000,000
T.V.	1930 – 1968	200,000,000
Newspapers		300,000,000

## The Vertical Breaking into the Horizontal

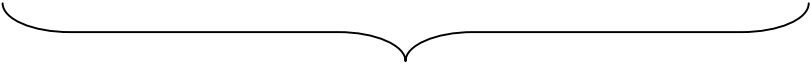
Subject	horizontal	vertical
EXACT SCIENCES	Scientific methods	intuition
EVOLUTION	causality	mutation
MEDICINE	technical	metaphysical
LAW	natural order	divine order
PHILOSOPHY	human reasoning	sudden enlightenment
LOGIC	dualistic	one-value logic
LANGUAGE	learning	universal grammar
LITERATURE ART	premeditation	sudden inspiration
		
GENERAL	secular time atomistic	spiritual eternal comprehensive

## Stages of Development of Consciousness

1. Atomistic thinking
2. Linear thinking
3. Functional thinking
4. Operational thinking
5. Structural consciousness
6. Dimensional consciousness
7. Cybernetic consciousness
8. Comprehensive consciousness

### The Infinite

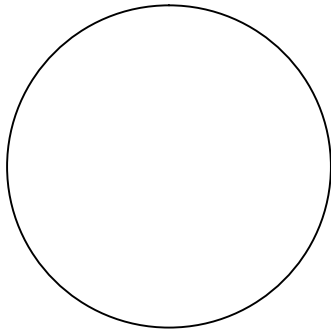

**Mysticism**

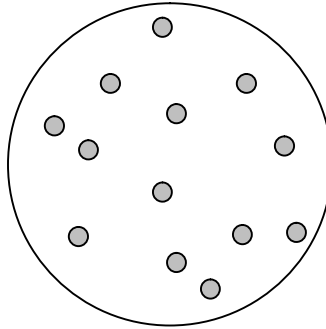

**Religion**

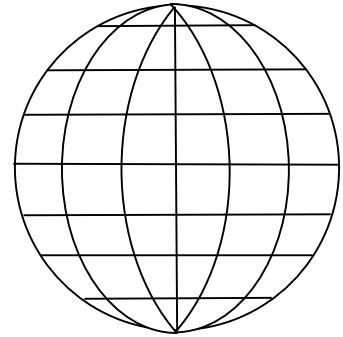

**Science**

<b>4</b>	<b>=</b>	<b>3 + 1</b>
		<b>7 + 3</b>
		<b>2 x 2</b>
		<b>12 ÷ 3</b>
		<b>2<sup>2</sup></b>
		<b>√16</b>
<b>a)</b>	<b>=</b>	<b>categories</b>
		<b>system</b>
<b>b)</b>	<b>=</b>	<b>creative</b>

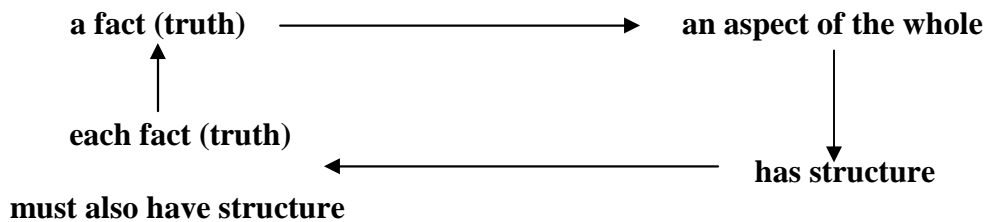

**The numerals of infinity, called seven days**  
(S&H 520:10)

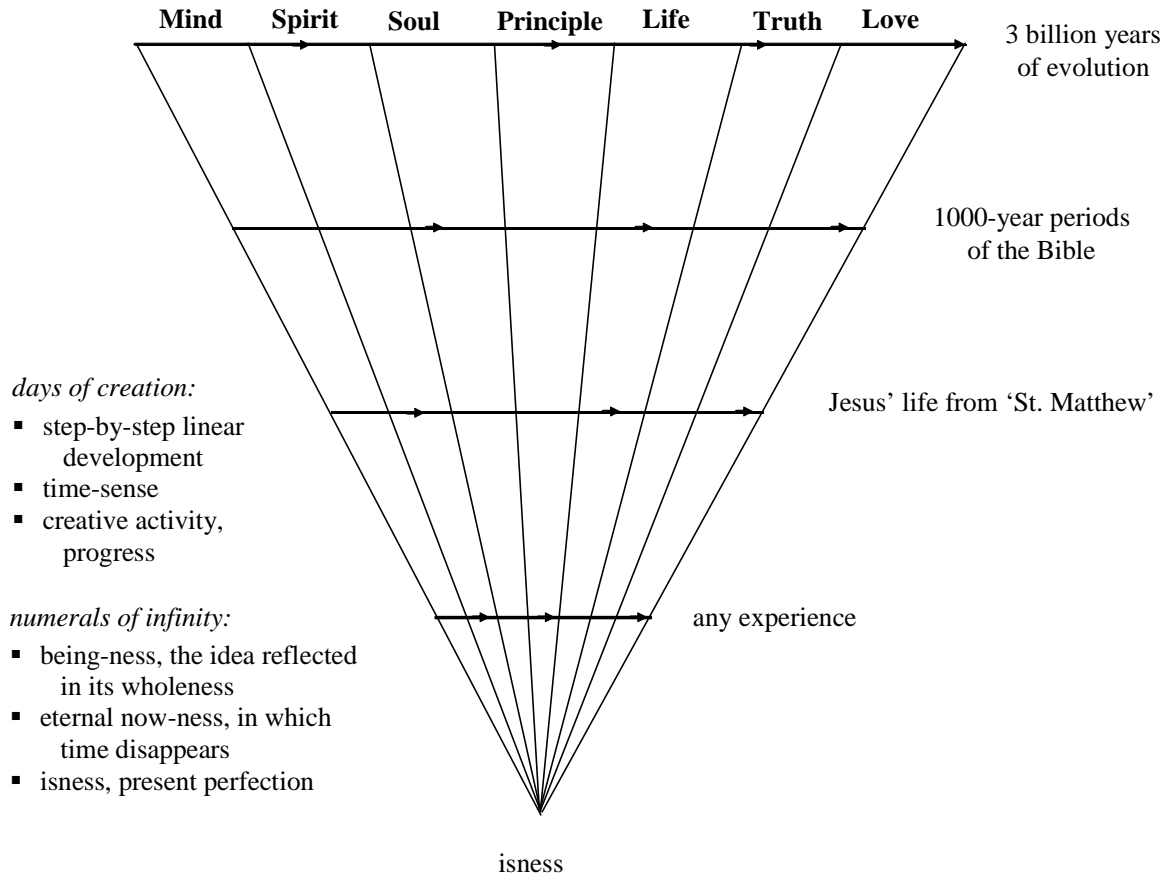

*days of creation:*

- step-by-step linear development
- time-sense
- creative activity, progress

*numerals of infinity:*

- being-ness, the idea reflected in its wholeness
- eternal now-ness, in which time disappears
- isness, present perfection

**References:**

**Books by Max Kappeler:**

*Compendium for the Study of Christian Science, No. 2: The Seven Days of Creation*, pp. 33–35.

*The Seven Synonyms for God*, chapter 2: the order of the seven days, also chapter 6: the Word-order.

**Recordings by Max Kappeler:**

A-6III: *Syllabus III*, 1978, Wilmington, DE, hours 8–10, 26–27.

B-2: *The Fundamentals of Christian Science*, 1970, Ogunquit, ME, hours 2–5.

C-1G: *Ch. XV, Genesis, The Structure of the Christian Science Textbook—Our Way of Life*, 1978, hours 13B–14A.

G-2: *The Science of Being—As I See It Today*, 1970, London, England, hours 2B–3.

M-33: *The days of creation and the numerals of infinity*, (4 hours from B-2, #2–5).

**Books by John Doorly:**

*God and Science—Symbols and their importance*, Publisher: London, F. Muller [©1949], statement pp. 15–16, 41–48, Appendix I, pp. 216–218.

*The Pure Science of Christian Science*, pp. 18–19, 47–48.

*Talks on the Science of the Bible*, Vol. I “red-book”, pp. 59–61, 63–65, 80–83, 155–157, 259–260, 272–274.

*Talks on the Science of the Bible*, Vol. II “red-book”, pp. 54–55.

*Talks at the Oxford Summer School, 1948*, Vol. I, p. 20.

*Talks at the Oxford Summer School, 1949*, Vol. II, pp. 136–137, 145–146, 148–151, 156–157.

**Prism and Lens:  
An Explanation of Mary Baker Eddy's Statements**

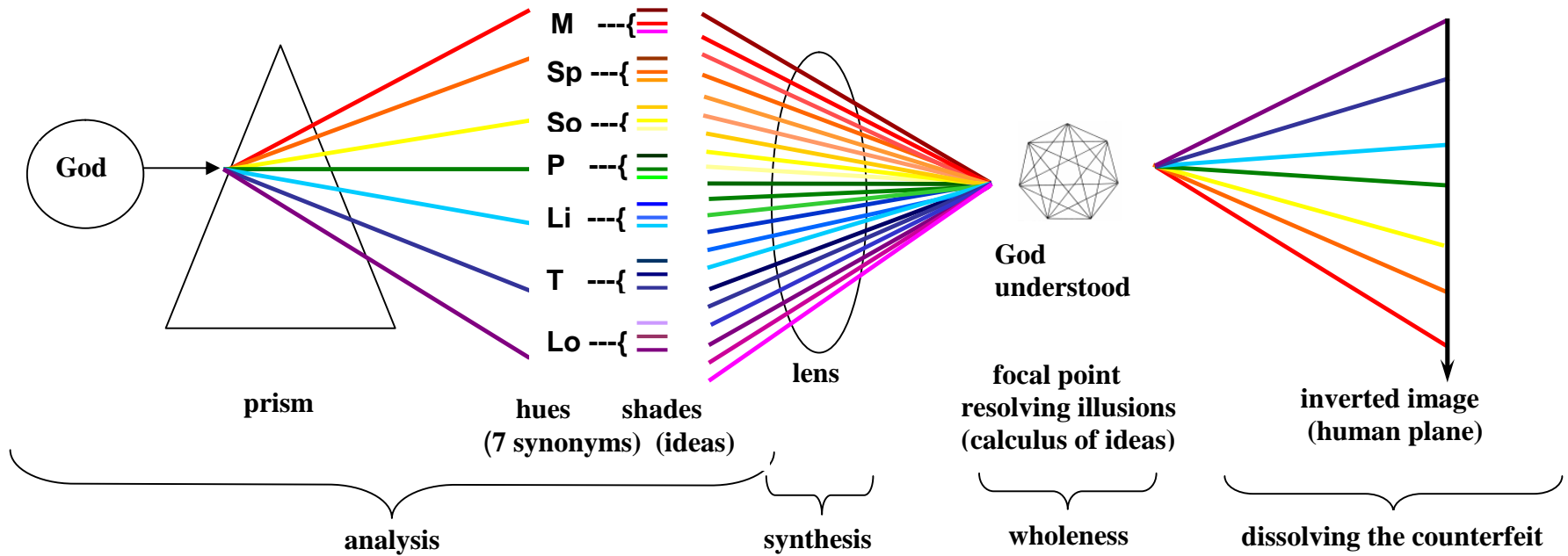

**“Science is the prism of Truth, which divides its rays and brings out the hues of Deity.”**  
 (Ret. 35:13–14)

**“The lens of Science magnifies the divine power to human sight; and we then see the allness of Spirit, therefore the nothingness of matter.”**  
 (’01 12:22–24)

**“The rays of infinite Truth, when gathered into the focus of ideas, bring light instantaneously...”**  
 (S&H 504:23-24)

**“Delusion, sin, disease, and death arise from the false testimony of material sense, which, from a supposed standpoint outside the focal distance of infinite Spirit, presents an inverted image of Mind and substance with everything turned upside down.”**  
 (S&H 301:24–29)

## References for “Prism and Lens”:

### Books by Max Kappeler:

*Introduction to the Science of Christian Science.*

*The Bible in the Light of Christian Science*, Vol. I: Genesis, p. 93.

### Recordings by Max Kappeler:

A-1: *An Introduction to the Science of Christian Science*, 1962, Zürich, Switzerland, hour 3A.

A-4: *The Structure-principle of Being*, 1974, Wilmington, DE, hours 4–6.

B-2: *From Atomistic Thinking to Cybernetic Comprehensive Consciousness*, 1970, Ogunquit, ME, hours 4–5.

D-4: *Divine Cybernetics and the Self-operating “Dimensional Laws” of the One Being: God: Word (Part I), Word (Part II), The Christ (Part III), Christianity (Part IV), Science (Part V)*, 1971/72, New York, hour 2.

G-2: *The Science of Being, as I See it Today*, 1970, London, England, hour 3.

**linear**



**reflection**

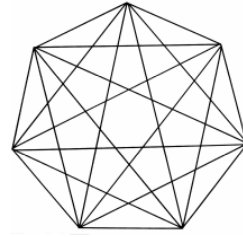

**City foursquare**  
**closed system** (*S&H* 575: 18-19)

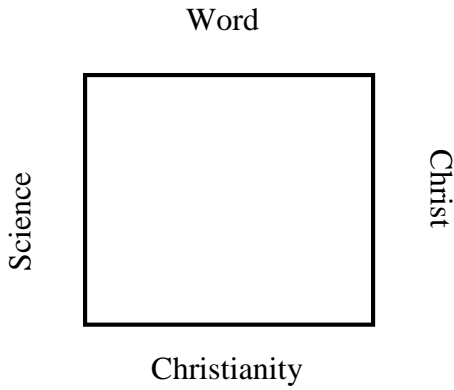

**The city of our God**  
**open system** (*S&H* 577: 14)

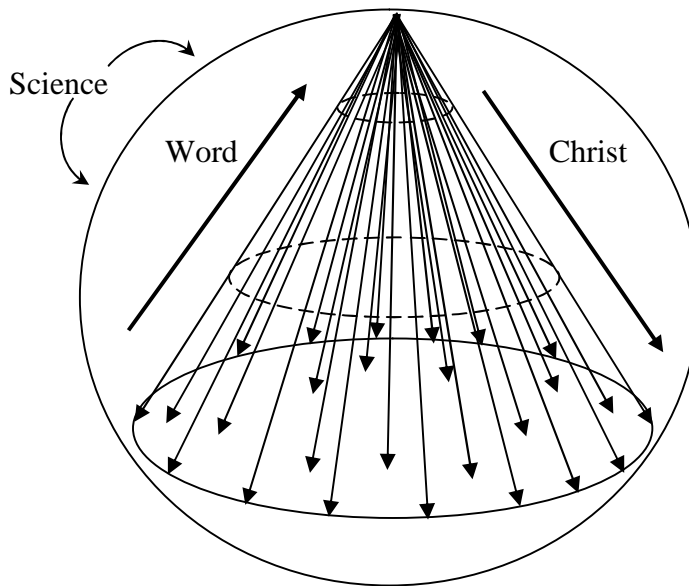
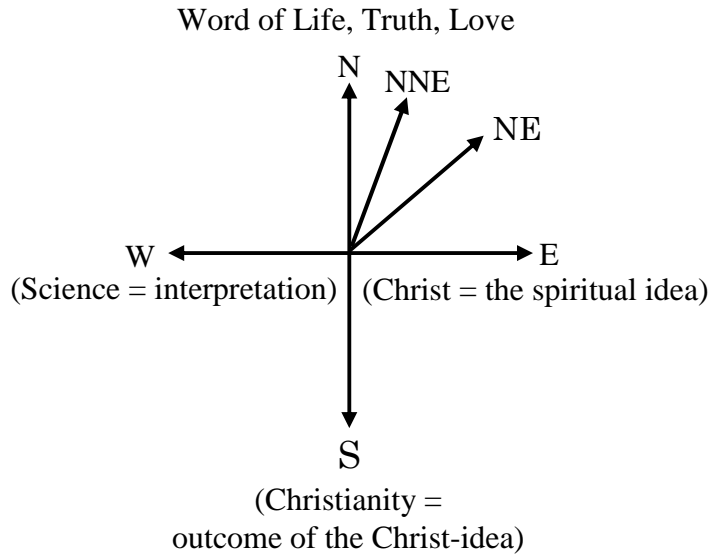



**The four operating as the seven through divine order**  
(S&H 465:9–10)

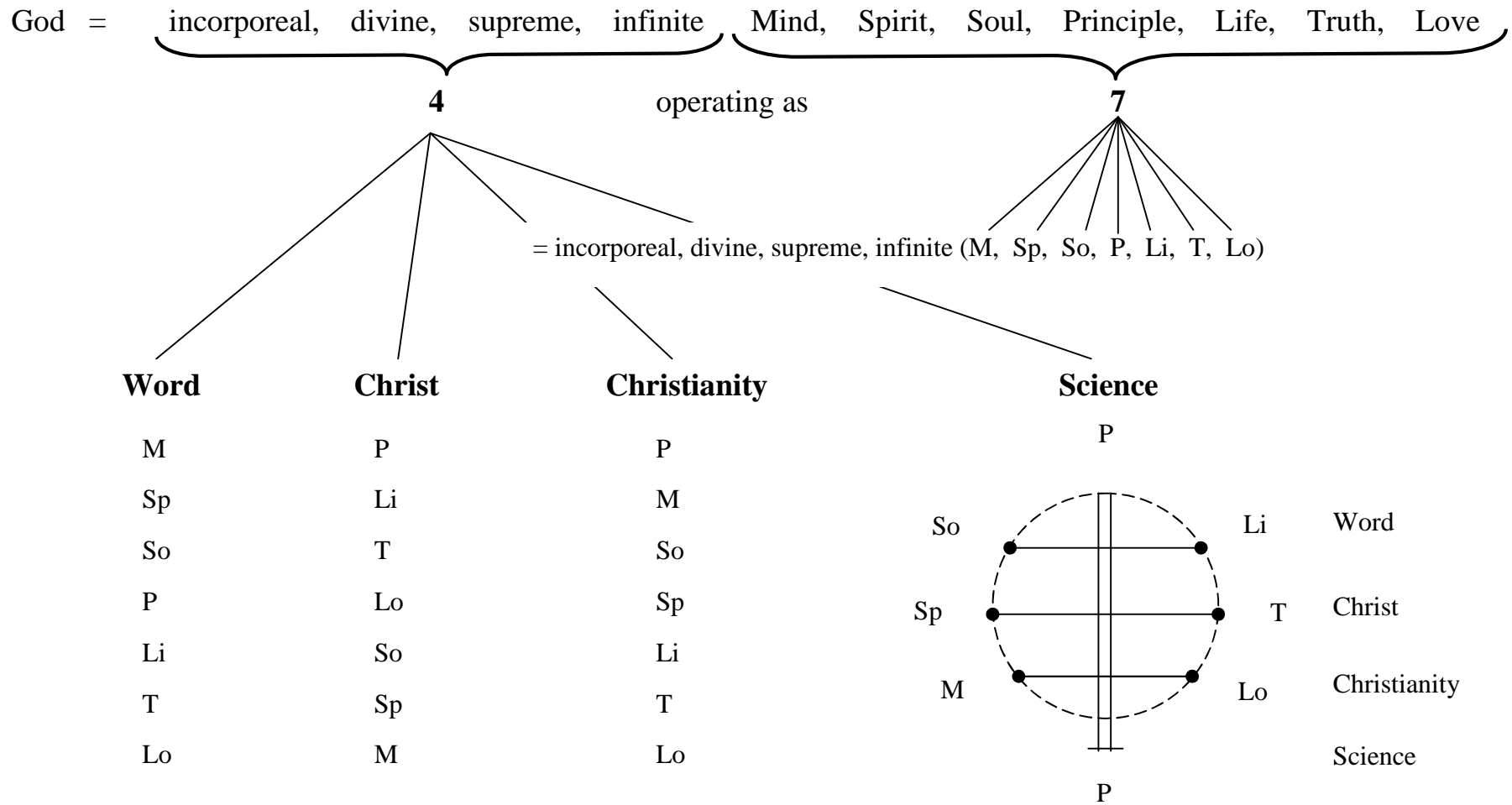

## References for the previous diagram: ‘The four operating as the seven through divine order’

### Books by Max Kappeler:

*The Seven Synonyms for God*, chapter 1, 2, 6.

### Recordings by Max Kappeler:

G-2: *The Science of Being, As I See It Today*, 1970 – London, England, hour 3.

### Books by John Doorly:

*Christian Science Practice*, pp. 31–34, 45.

*The Pure Science of Christian Science*, pp. 49–51.

*Talks at the Oxford Summer School, 1948*, Vol. I, pp. 232–233 (the nature of divine order), also p. 255.

*Talks on the Science of the Bible*, Vol. II “red-book”, pp. 393–394.

*Talks on the Science of the Bible*, Vol. VI “red-book”, pp. 179–180, 205–206.

*Talks on the Science of the Bible*, Vol. IX “red-book”, pp. 112–113 (4 orders), 127.

examples of the four orders:

### ‘Prayer’: Word-order

Books by Max Kappeler:

*The Structure of the Christian Science Textbook*, pp. 10–15

*Epitomes for the Spiritually Structured Interpretation of the Christian Science Textbook*, pp. 2–4

Recording by Max Kappeler:

C-1PR: CH. I, *Prayer, The Structure of the Christian Science Textbook—Our Way of Life*, 27 hours

### Joshua and Judges: each in the Word-order (7 x7)

Book by Max Kappeler:

*The Bible in the Light of Christian Science*, Vol. III: Joshua, Judges

Book by John Doorly:

*Talks on the Science of the Bible*, Vol. IV “red-book”

### I and II Samuel: Word-order

Book by Max Kappeler:

*The Bible in the Light of Christian Science*, Vol. IV: I & II Samuel

Book by John Doorly:

*Talks on the Science of the Bible*, Vol. V “red-book”.

Note: The vast majority of texts in the Bible and in ‘Science and Health with key to the Scriptures’ are laid out in the Word-order, so examples abound.

### II Kings: Christ-order

Book by John Doorly:

*Talks on the Science of the Bible*, Vol. VI “red-book”, pp. 149–293

### Jeremiah: Christ-order

Book by Max Kappeler:

*The Minor Prophets in the Light of Christian Science*, pp. 178–181

Book by John Doorly:

*Talks at the Oxford Summer School, 1948*, Vol. I, pp. 109–256

### Romans: Christ-order

Book by Max Kappeler:

*The Epistles in the Light of Christian Science*. pp. 45–60

Recording by Max Kappeler:

A-6IV: *Syllabus IV*, 1979, Wilmington, DE, hour 11–17

### Isaiah: Word, Christ, Christianity orders

Books by John Doorly:

*Talks on the Science of the Bible*, No. 73 “blue book”, pp. 25–31

*Talks on the Science of the Bible*, No. 74 “blue book”, pp. 1–21

### Daniel: Word Christ, Christianity, and Science orders

Book by Max Kappeler:

*The Minor Prophets in the Light of Christian Science*, pp. 185–188

Book by John Doorly:

*Talks on the Science of the Bible*, Vol. IX “red-book”, pp. 157–188 (in full, pp. 15–188)

### Zechariah: Word, Christ, Christianity, and Science orders

Book by Max Kappeler:

*The Minor Prophets in the Light of Christian Science*, pp. 140–159

Book by John Doorly:

*Talks on the Science of the Bible*, Vol. IX “red-book”, pp. 314–386

### I John: Word, Christ, Christianity, and Science orders

Book by Max Kappeler:

*The Epistles in the Light of Christian Science*. pp. 212–22

The Science of Being—As I See It Today, Tape code G-2

©1970, 2006 Kappeler Institute for the Science of Being, PO Box 99735, Seattle, WA 98139-0735. All rights reserved.

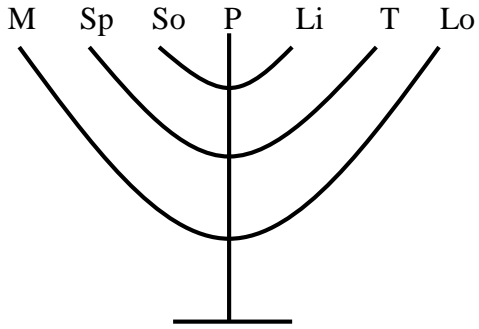

**candlestick**

---

linear	2	4	6	8	10	12	14
exponential	2	4	8	16	32	64	128

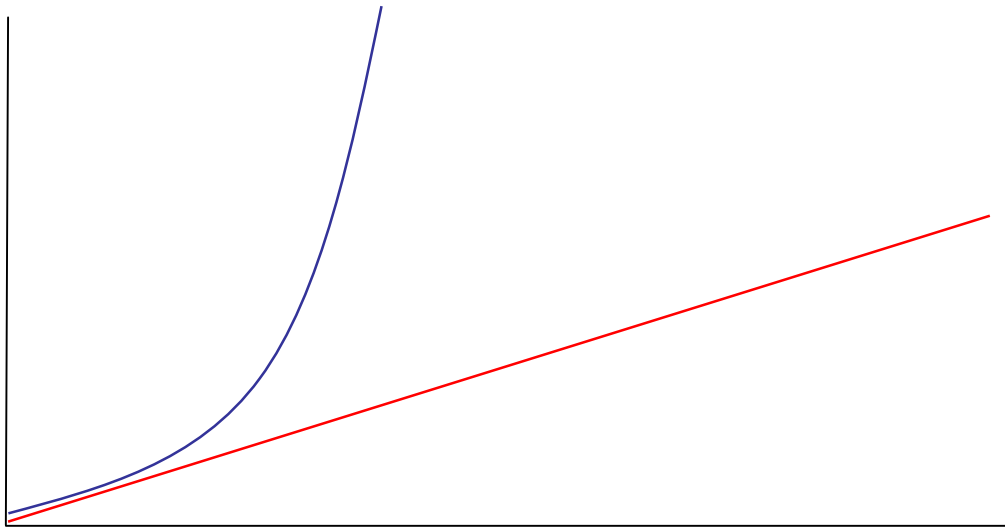

**order becomes structure**

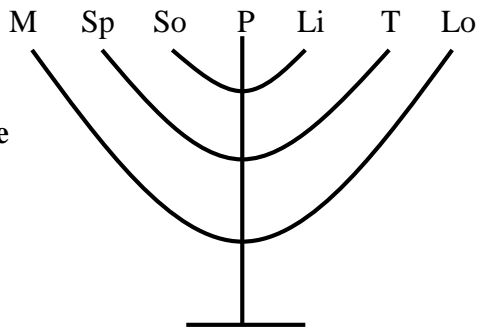

### structural consciousness (Gauss)

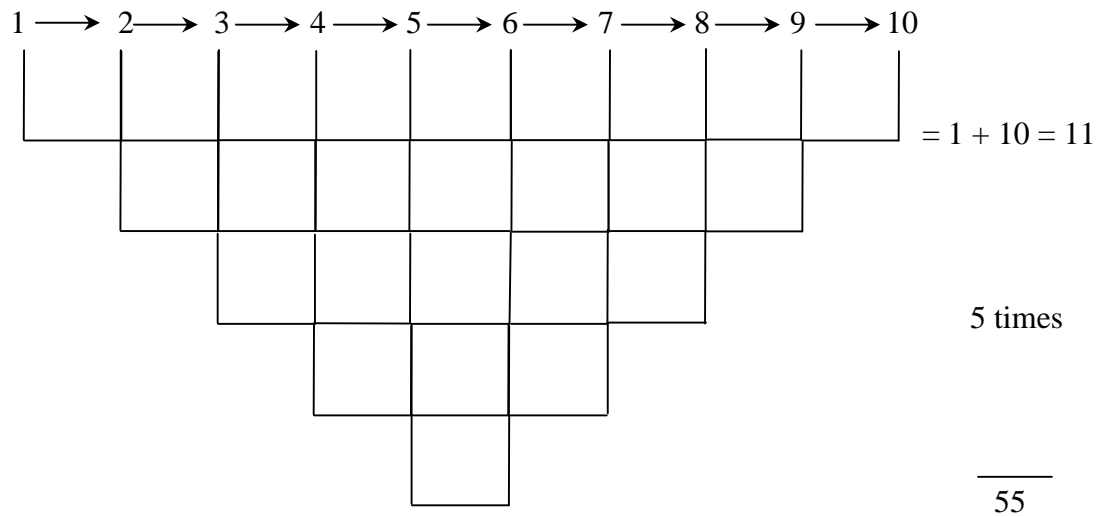

$$1 + \dots + 100 = 101$$

$\frac{100}{2} = 50$ 
X
 $\frac{50}{5050}$

## Structure

<i>structura</i>	=	to arrange; to fit together (system = to place together)
structure	=	the interrelationships of parts as dominated by the general character of the whole. (Webster)
	=	the sum total of relationships which maintains the communication between the different parts of the whole. (Prof. Amar)

## Attitude

### *Structural*

has the whole in view  
considers structure  
always has a new perspective  
center: the whole  
the whole has its own solution

### *atomistic*

narrow-mindedness  
engulfed in details  
pedantic  
routine  
repetitive  
center: personal "I"  
meets our own desires

## New Mathematics

0	1	2	3	4	5	6	7	8	9
10	11	12	13	14	15	16	17	18	19
20	21	22	23	24	25	26	27	28	29
30	31	32	33	34	35	36	37	38	39
40	41	42	43	44	45	46	47	48	49
50	51	52	53	54	55	56	57	58	59
60	61	62	63	64	65	66	67	68	69
70	71	72	73	74	75	76	77	78	79
80	81	82	83	84	85	86	87	88	89
90	91	92	93	94	95	96	97	98	99

0					5				
10					15				
20					25				
30					35				
40					45				
50					55				
60					65				
70					75				
80					85				
90					95				

0			3			6			9
		14			15			18	
	21			24			27		
30			33			36			39
		42			45			48	
	51			54			57		
60			63			66			69
		72			75			78	
	81			84			87		
90			93			96			99

0						6			
	12							18	
			24						
30					36				
	42							48	
			54						
60					66				
	72							78	
			84						
90					96				

### Kékulé (benzene ring)

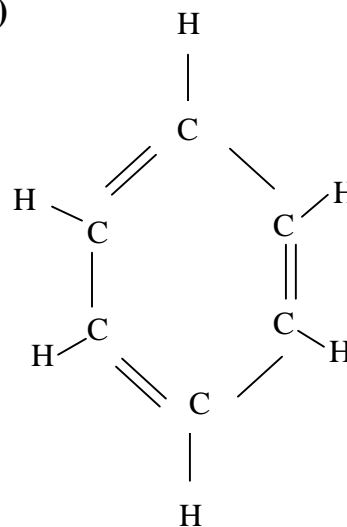
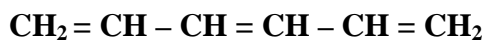

### Synonyms-Matrix

SYNONYM	MIND	SPIRIT	SOUL	PRINCIPLE	LIFE	TRUTH	LOVE
Mind	M	Sp	So	P	Li	T	Lo
	M	M	M	M	M	M	M
Spirit	M	Sp	So	P	Li	T	Lo
	Sp	Sp	Sp	Sp	Sp	Sp	Sp
Soul	M	Sp	So	P	Li	T	Lo
	So	So	So	So	So	So	So
Principle	M	Sp	So	P	Li	T	Lo
	P	P	P	P	P	P	P
Life	M	Sp	So	P	Li	T	Lo
	Li	Li	Li	Li	Li	Li	Li
Truth	M	Sp	So	P	Li	T	Lo
	T	T	T	T	T	T	T
Love	M	Sp	So	P	Li	T	Lo
	Lo	Lo	Lo	Lo	Lo	Lo	Lo

## Calculus-matrix

CALCULUS	WORD	CHRIST	CHRISTIANITY	SCIENCE
Word	W/W	X/W	Xty/W	Sc/W
Christ	W/X	X/X	Xty/X	Sc/X
Christianity	W/Xty	X/Xty	Xty/Xty	Sc/Xty
Science	W/Sc	X/Sc	Xty/Sc	Sc/Sc

## Prophets

CALCULUS	WORD	CHRIST	CHRISTIANITY	SCIENCE
Word	W/W	X/W	Xty/W	Sc/W
Christ	W/X	X/X	Xty/X	Sc/X
Christianity	W/Xty	X/Xty	Xty/Xty	Sc/Xty
Science	W/Sc	X/Sc	Xty/Sc	Sc/Sc



## MIND-matrix

MIND	WORD	CHRIST	CHRISTIANITY	SCIENCE
Word	1.	5.	9.	13.
Christ	2.	6.	10.	14.
Christianity	3.	7.	11.	15.
Science	4.	8.	12.	16.

MIND	WORD <i>MIND is ALL</i>	CHRIST <i>The POWER of MIND</i>	CHRISTIANITY <i>The allness of MIND</i>	SCIENCE <i>MIND and MIND's idea is one</i>
Word	1.	5.	9.	13.
Christ	2.	6.	10.	14.
Christianity	3.	7.	11.	15.
Science	4.	8.	12.	16.

## Evil-matrix

EVIL	WORD	CHRIST	CHRISTIANITY	SCIENCE
Word	1.	5.	9.	13.
Christ	2.	6.	10.	14.
Christianity	3.	7.	11.	15.
Science	4.	8.	12.	16.

EVIL	WORD <i>to free ourselves from evil</i>	CHRIST <i>Evil has no power</i>	CHRISTIANITY <i>Superiority of good over evil</i>	SCIENCE <i>Providing good = disproving evil</i>
Word	1.	5.	9.	13.
Christ	2.	6.	10.	14.
Christianity	3.	7.	11.	15.
Science	4.	8.	12.	16.

# Calculus-matrices

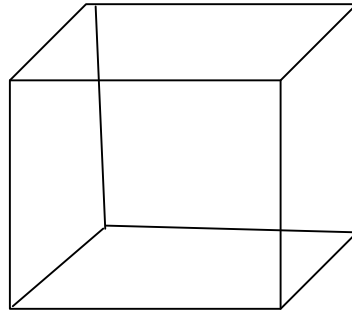

WORD

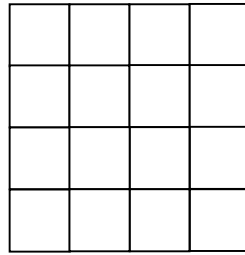

SCIENCE

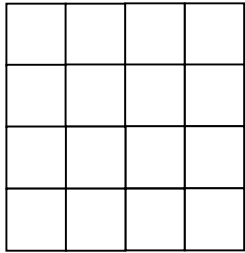

↑  
W

CHRIST

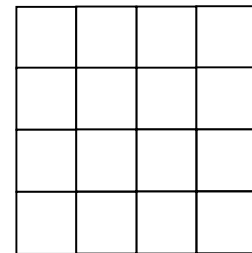

← Sc

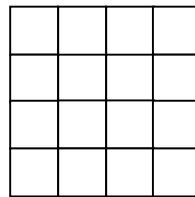

X →

Xty

↓

CHRISTIANITY

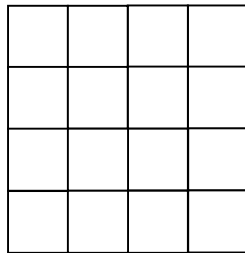

## WORD-matrix

WORD	WORD	CHRIST	CHRISTIANITY	SCIENCE
Word	1.	5.	9.	13.
Christ	2.	6.	10.	14.
Christianity	3.	7.	11.	15.
Science	4.	8.	12.	16.

## CHRIST-matrix

CHRIST	WORD	CHRIST	CHRISTIANITY	SCIENCE
Word	1.	5.	9.	13.
Christ	2.	6.	10.	14.
Christianity	3.	7.	11.	15.
Science	4.	8.	12.	16.

CHRIST	WORD <i>Mono- potency of good</i>	CHRIST <i>Reforming power</i>	CHRISTIANITY <i>Restoration of the idea</i>	SCIENCE <i>Operation of idea in its Principle</i>
Word <i>divine purpose defined</i>	1.	5.	9.	13.
Christ <i>Translation of two-ness into one-ness</i>	2.	6.	10.	14.
Christianity <i>Evil disappears Good appears</i>	3.	7.	11.	15.
Science <i>understanding</i>	4.	8.	12.	16.

## CHRISTIANITY-matrix

CHRISTIANITY	WORD	CHRIST	CHRISTIANITY	SCIENCE
Word	1.	5.	9.	13.
Christ	2.	6.	10.	14.
Christianity	3.	7.	11.	15.
Science	4.	8.	12.	16.

CHRISTIANITY	WORD <i>The grace of God</i>	CHRIST <i>The glory of Christ</i>	CHRISTIANITY <i>Man's perfection</i>	SCIENCE <i>The Science of man</i>
Word <i>accepting</i>	1.	5.	9.	13.
Christ <i>claiming</i>	2.	6.	10.	14.
Christianity <i>abiding</i>	3.	7.	11.	15.
Science <i>proving by living</i>	4.	8.	12.	16.

**DIMENSIONALISM**  
(against reductionism)

Diagram A

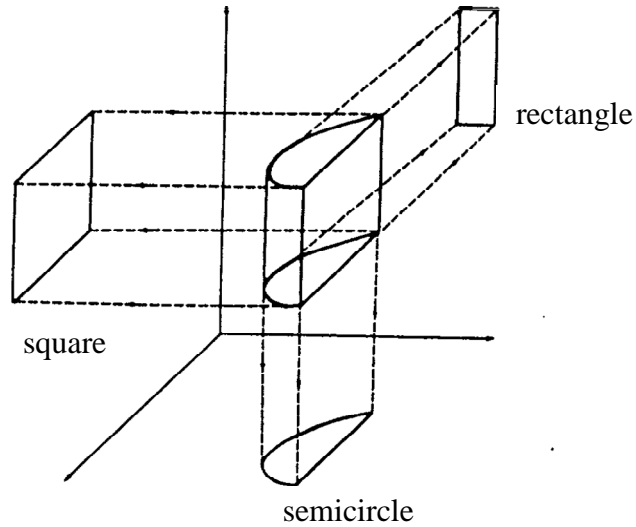

Diagram B

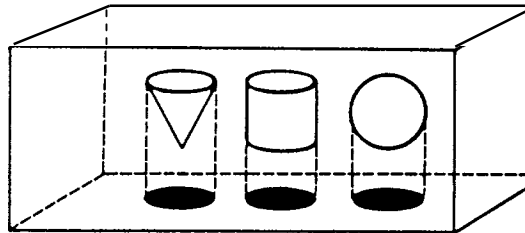
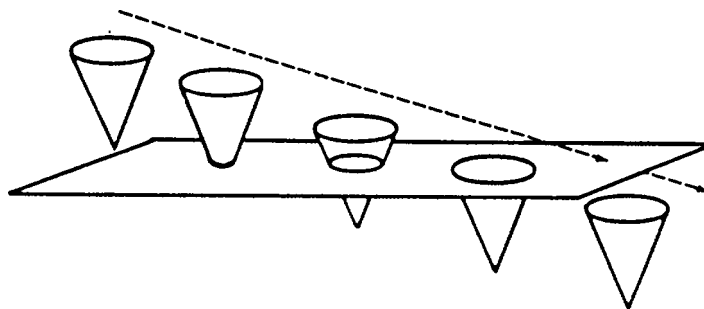

Diagram C



**References:**

**Recordings by Max Kappeler:**

- A-4: *The Structure-principle of Being*, 1974, Wilmington, DE, hour 20.
- A-6V: *Syllabus V*, 1980, hour 3.
- B-2: *From Atomistic Thinking to Cybernetic Comprehensive Consciousness*, 1970, Ogunquit, ME, hour 17.
- D-4: *Divine Cybernetics and the Self-operating "Dimensional Laws" of the One Being: God*, 1971/72, New York, hour 3.

- G-2: *The Science of Being—As I See It Today*, 1970, London, England, hours 6–7.

**Books by Max Kappeler:**

- The Seven Synonyms for God*, Chapter 7.
- The Science of the Oneness of Being in the Christian Science Textbook*, pp. 49–51.

The Science of Being—As I See It Today, Tape code G-2

©1970, 2006 Kappeler Institute for the Science of Being, PO Box 99735, Seattle, WA 98139-0735. All rights reserved.

## The Chart

### 1<sup>st</sup> category

WORD	CHRIST	CHRISTIANITY	SCIENCE

### 2<sup>nd</sup> category

Science	Principle itself	One
Divine Science	Principle and idea = One	oneness
absolute Christian Science	Relationship of Principle to ideas	unity
Christian Science	ideas versus illusions	makes one



## The Chart

combining 1<sup>st</sup> and 2<sup>nd</sup> categories

Science				
	WORD	CHRIST	CHRISTIANITY	SCIENCE
Divine Science				
absolute Christian Science				
Christian Science				

Science	Principle																		
	WORD	CHRIST	CHRISTIANITY	SCIENCE															
Divine Science	Li	T	Lo	divine Principle, Love															
absolute Christian Science	Li T Lo	T Li Lo	Li Lo	T Lo															
Christian Science	M Sp So P Li T Lo	P Li T Lo So Sp M	P M So Sp Li T Lo	<table style="margin: auto; border: none;"> <tr> <td></td> <td style="text-align: center;">P</td> <td></td> </tr> <tr> <td style="text-align: center;">So</td> <td style="text-align: center;">⋮</td> <td style="text-align: center;">Li</td> </tr> <tr> <td style="text-align: center;">Sp</td> <td style="text-align: center;">⋮</td> <td style="text-align: center;">T</td> </tr> <tr> <td style="text-align: center;">M</td> <td style="text-align: center;">⋮</td> <td style="text-align: center;">Lo</td> </tr> <tr> <td></td> <td style="text-align: center;">P</td> <td></td> </tr> </table>		P		So	⋮	Li	Sp	⋮	T	M	⋮	Lo		P	
	P																		
So	⋮	Li																	
Sp	⋮	T																	
M	⋮	Lo																	
	P																		

## Platform

PLATFORM	WORD	CHRIST	CHRISTIANITY	SCIENCE
Word	1	9	17	25
	2	10	18	26
Christ	3	11	19	27
	4	12	20	28
Christianity	5	13	21	29
	6	14	22	30
Science	7	15	23	31
	8	16	24	32

## CHRIST-matrix (Prophets)

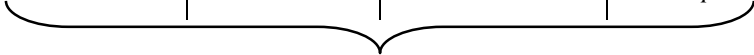
CHRIST	WORD  <i>Mono-potency of good</i>	CHRIST  <i>Reforming power</i>	CHRISTIANITY  <i>Restoration of the idea</i>	SCIENCE  <i>Operation of idea in its Principle</i>
	 absolute Christian Science			
<b>Word</b>  <i>Divine purpose defined</i>	1.	5.	9.	13.
<b>Christ</b>  <i>Translation of two-ness into one-ness</i>	2.	6.	10.	14.
<b>Christianity</b>  <i>Evil disappears Good appears</i>	3.	7.	11.	15.
<b>Science</b>  <i>Understanding</i>	4.	8.	12.	16.

## CHRISTIANITY-matrix (Epistles)

CHRISTIANITY	WORD <i>The grace of God</i>	CHRIST <i>The glory of Christ</i>	CHRISTIANITY <i>Man's perfection</i>	SCIENCE <i>The Science of man</i>
	 absolute Christian Science			
Word <i>accepting</i>	1.	5.	9.	13.
Christ <i>Translation of claiming</i>	2.	6.	10.	14.
Christianity <i>abiding</i>	3.	7.	11.	15.
Science <i>proving by living</i>	4.	8.	12.	16.

## The Law of Gravitation

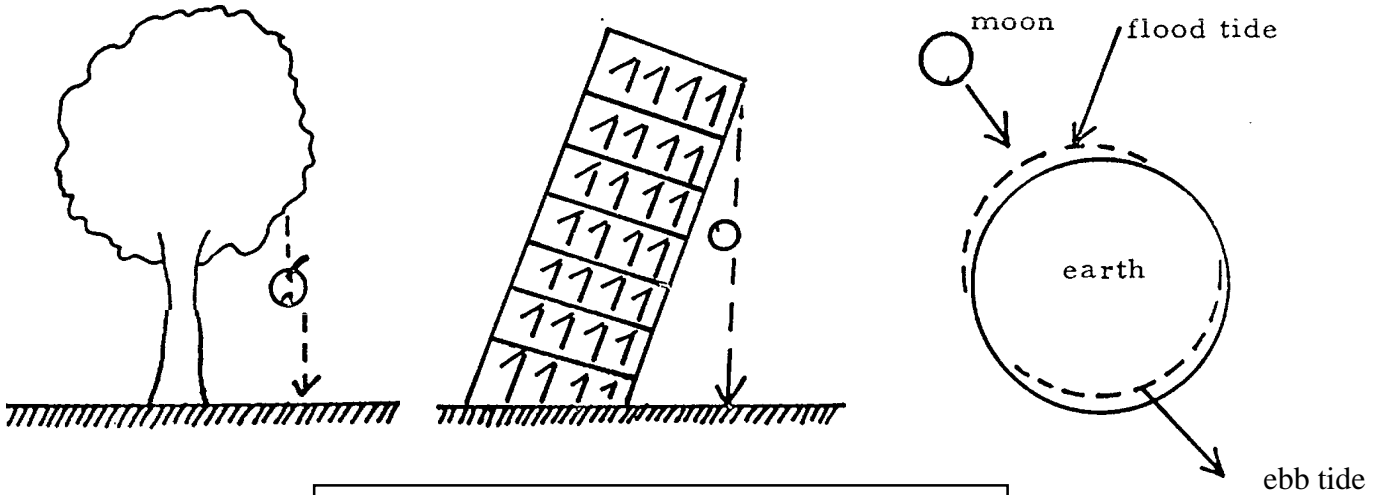

law:

$$F = g \frac{m_1 \cdot m_2}{r^2}$$

## The Law of Interdependence

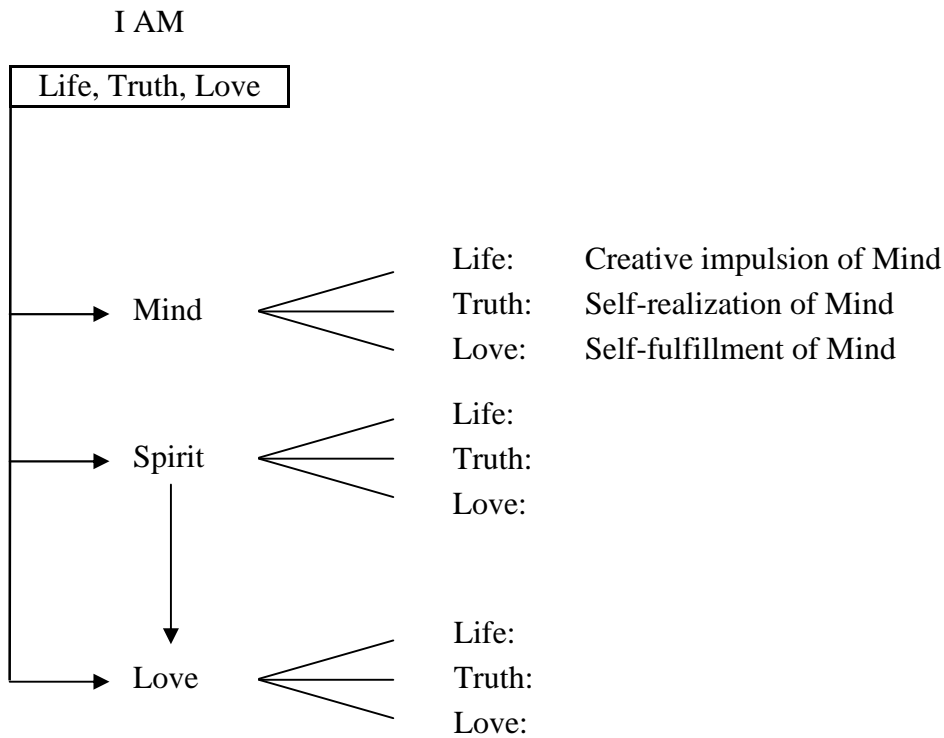

## Examples of Dimensionalism

Sciences (Müller-Markus)	4. noosphere 3. psychosphere 2. biosphere 1. cosmosphere
Psychology	4. super-conscious 3. unconscious 2. subconscious 1. humanly conscious
Psychedelic (Masters & Houston)	4. integral level 3. symbolic level 2. memorial-analytical level 1. sensoric level
T. de Chardin	4. Christo genesis 3. noogenesis 2. biogenesis 1. cosmogenesis
Philosophy (N. Hartmann)	4. Spirit 3. Soul and its phenomena 2. living things 1. objects and physical process

## Divine Cybernetics

homeostasis:	<i>homeo</i> = equal <i>stasis</i> = static
homeorhese:	<i>homeo</i> = equal <i>rhese</i> = flowing

## Divine Cybernetic Model

Science itself				
	Word	Christ	Christianity	Science
divine Science	input	process	output	feedback
absolute Christian Science				
Christian Science				

### divine cybernetics presents:

- |                                  |   |
|----------------------------------|---|
| Science itself                   | the one infinite Being  |
| divine Science                   | as a self-organizing system,<br>running on a self-regulating<br>circuit |
| absolute<br>Christian<br>Science | that has positive feedback<br>(is error-preventing)                     |
| Christian Science                | as well as negative feedback<br>(is error-correcting)                   |

### Logicity of Science

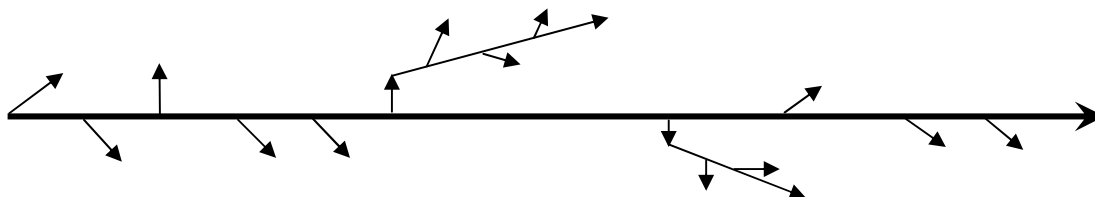

The Science of Being—As I See It Today, Tape code G-2  
 ©1970, 2006 Kappeler Institute for the Science of Being, PO Box 99735, Seattle, WA 98139-0735. All rights reserved.

## The Theory of Evolution (Prof. Eigen, 1970)

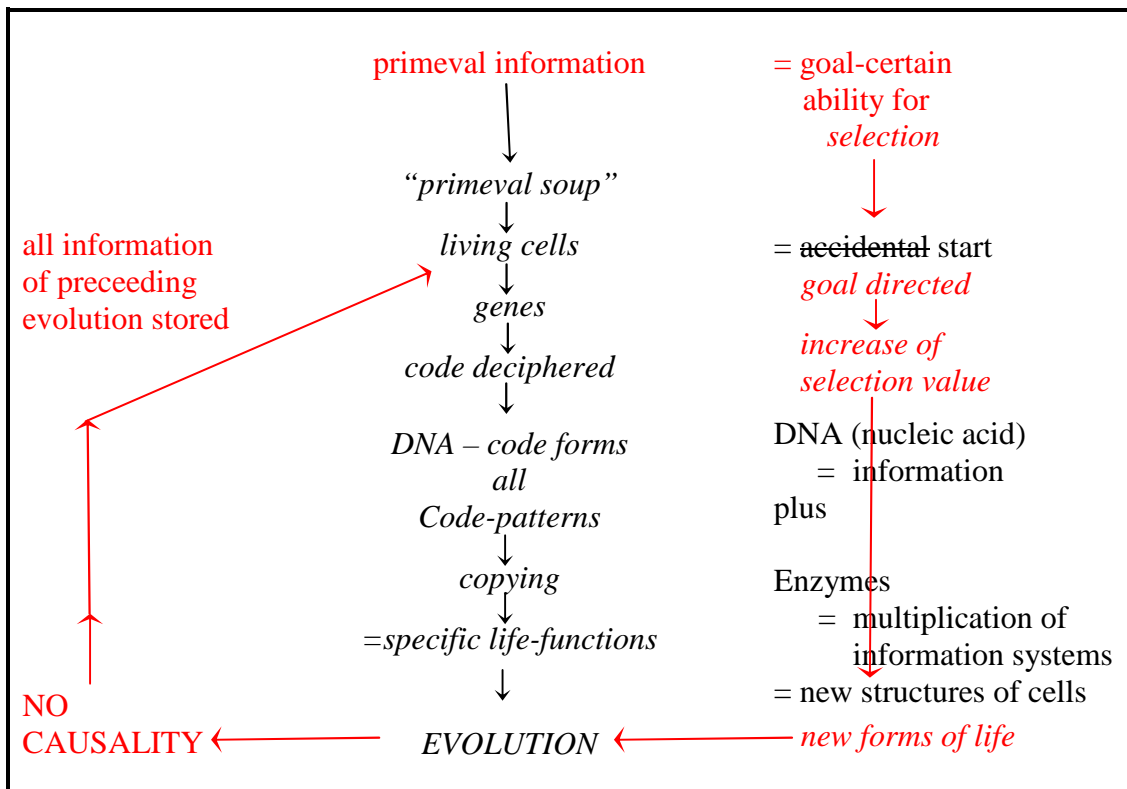
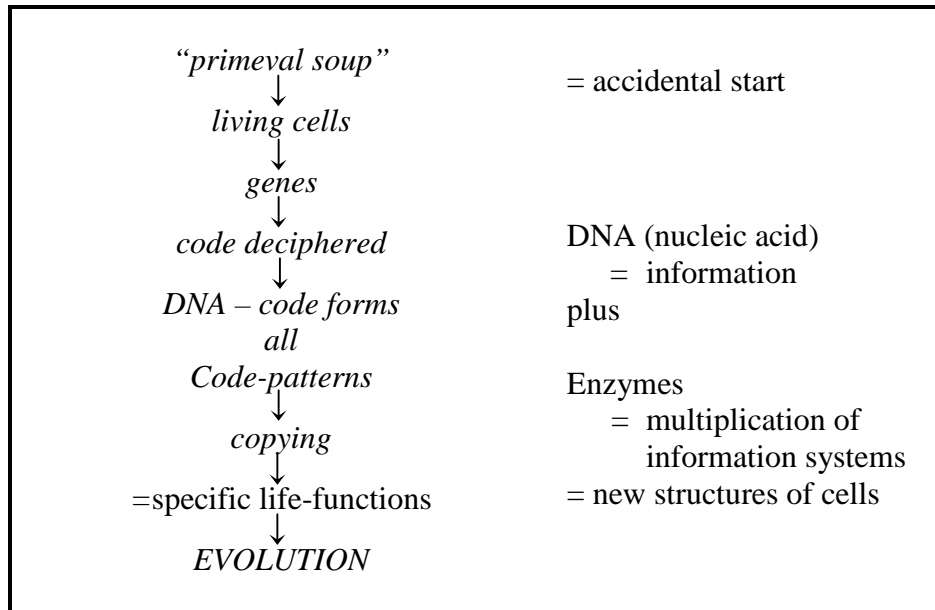



## The Theory of Evolution (Prof. Eigen, 1970)

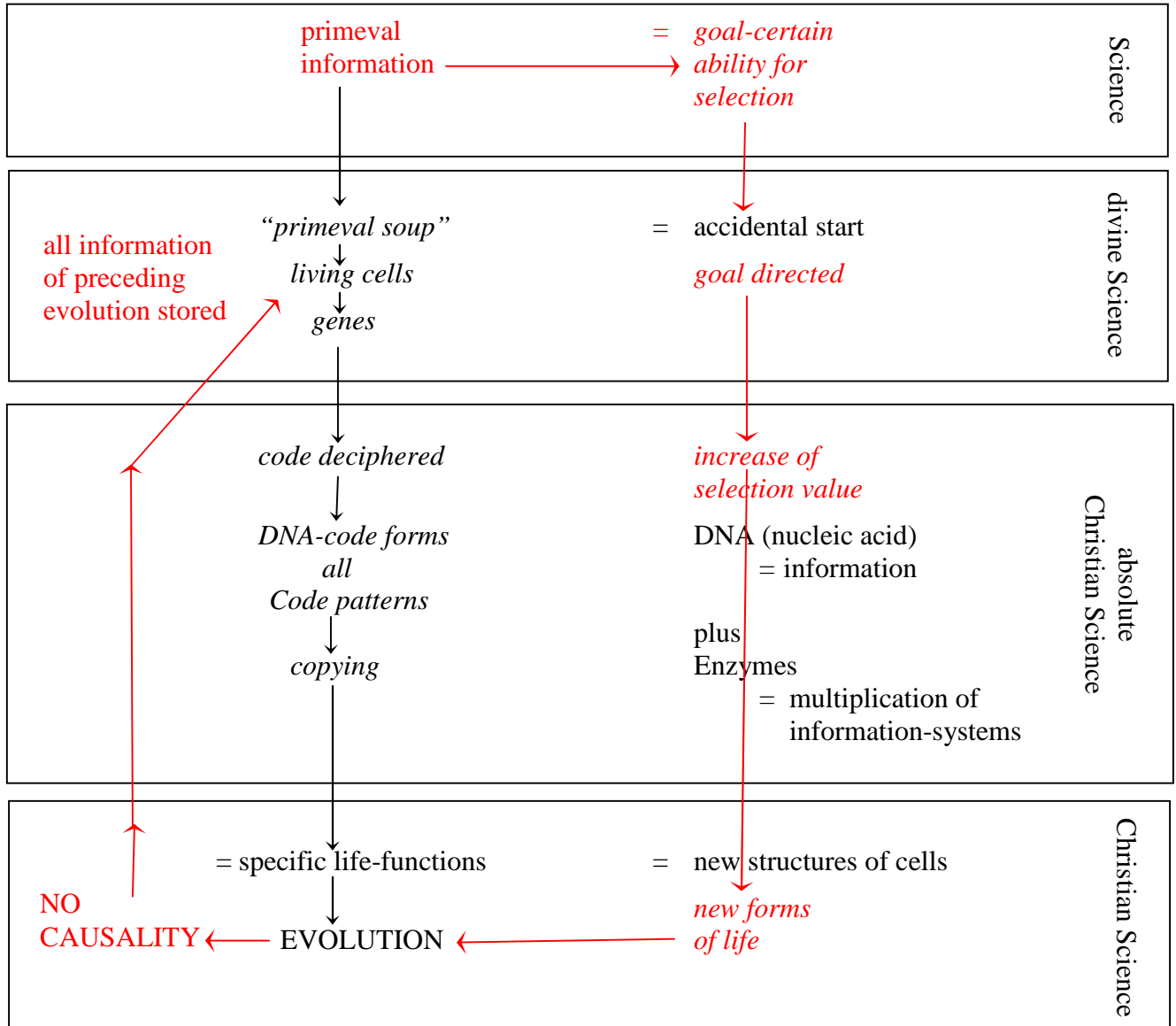

## Mother – Church

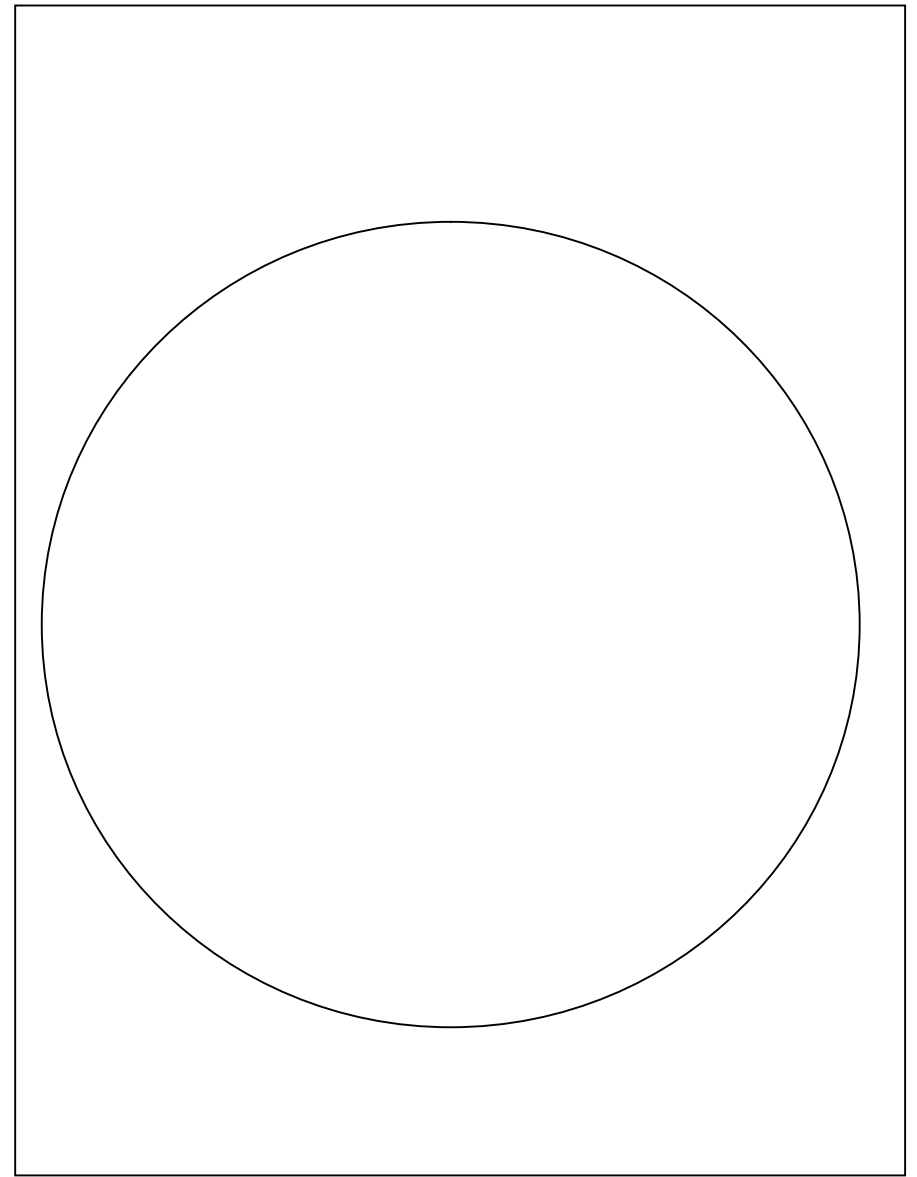
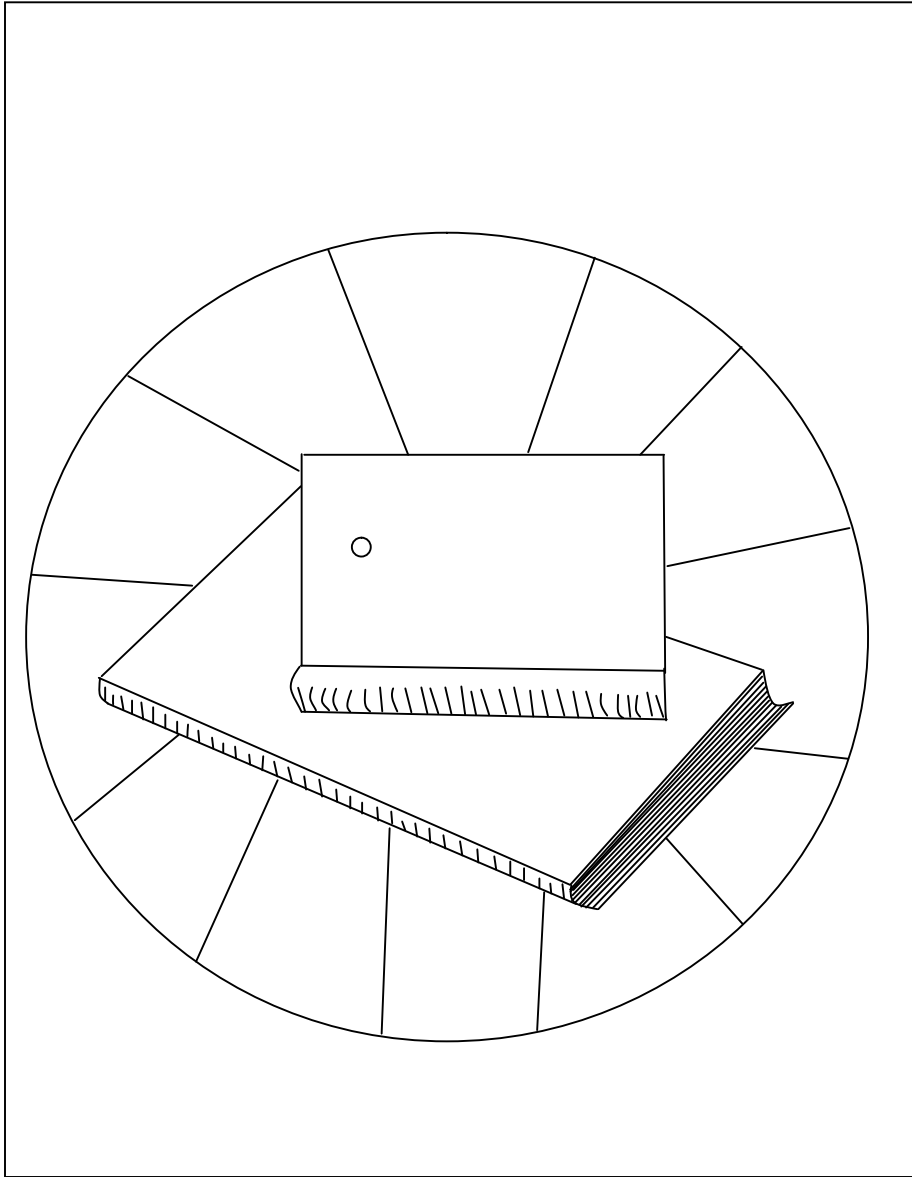



**KAPPELER INSTITUTE RECORDINGS**

**ILLUSTRATIVE MATERIAL**

**THE MODEL OF BEING  
AND ITS UNIVERSAL LAWS  
(Tape Code G-3)**

**Max Kappeler**

©1987, 2005 Kappeler Institute for the Science of Being  
All rights reserved



Kappeler Institute Publishing  
P.O. Box 99735  
Seattle, WA 98139-0735  
Tel: (206) 286-1617 • Fax: (206) 286-1675  
E-mail: [mail@kappelerinstitute.org](mailto:mail@kappelerinstitute.org)  
[www.kappelerinstitute.org](http://www.kappelerinstitute.org)  
Division of Kappeler Institute for the Science of Being, USA  
Seattle, WA USA

# Contents

## The Model of Being and its Universal Laws

(Tape code: G-3)

©1987, 2005 Kappeler Institute for the Science of Being

AUDIO RECORDING NUMBER/SIDE	RECORDING SUBJECT
1-A	Introduction to the “model of Being” <ul style="list-style-type: none"><li>▪ consciousness determines experience</li><li>▪ the old worldview (the old story of science)<ul style="list-style-type: none"><li>– is dualistic</li><li>– uses method of reductionism</li></ul></li></ul>
1-B	<ul style="list-style-type: none"><li>• uses mechanical concept of the universe, of cause and effect</li><li>– does not take the observer into consideration</li></ul>
2-A	<ul style="list-style-type: none"><li>• recap of the old science</li><li>▪ the new worldview (the new story of science)<ul style="list-style-type: none"><li>– is holistic</li></ul></li></ul>
2-B	...continued
3-A	...continued
3-B	A. The fourfold aspect of holistic philosophy <ul style="list-style-type: none"><li>I. The object of investigation: The Model of Being: <i>the chart</i> ...continued</li><li>II. The holistic method of investigation: holistic science<ul style="list-style-type: none"><li>– holistic definition of science</li></ul></li></ul>
4-A	<ul style="list-style-type: none"><li>• recap of I and II</li><li>– elements</li><li>– categories vs. randomness</li></ul>
4-B	...continued <ul style="list-style-type: none"><li>– law</li><li>– system vs. linear logic</li></ul>
5-A	<ul style="list-style-type: none"><li>• structure/structuralism vs. atomism</li><li>– dimensions/dimensionalism vs. reductionism</li></ul>
5-B	<ul style="list-style-type: none"><li>• cybernetics vs. causality</li><li>– evolution/holism</li></ul>
	III. The method of holistic awareness

5-B CONT.	<p>IV. Holistic self-intelligence</p> <ul style="list-style-type: none"> <li>- information</li> <li>- holistic consciousness</li> <li>- divine philosophy (theology: holistic science; divine medicine – problem solving; holistic philosophy)</li> </ul>
6-A and B	<p>B. Christian Science fulfills the fourfold aspect of holistic philosophy</p>
7-A	<p>I. The object of investigation: God (theology)</p> <p>II. The holistic method of investigation: Christ Science</p> <ul style="list-style-type: none"> <li>- Science, divinely defined</li> </ul>
7-B	<p>...continued</p>
8-A	<ul style="list-style-type: none"> <li>• elements: ideas</li> </ul>
8-B	<ul style="list-style-type: none"> <li>- categories: three categories of capitalized terms</li> <li>...continued</li> <li>- law: interrelation of holistic categories</li> <li>- the holistic system: the model of Being</li> </ul>
9-A	<p>...continued</p> <ul style="list-style-type: none"> <li>- structure and restructuring</li> </ul>
9-B	<p>...continued</p> <ul style="list-style-type: none"> <li>- dimensionalism: hierarchy of structures</li> </ul>
10-A	<ul style="list-style-type: none"> <li>• divine cybernetics</li> </ul>
10-B	<p>...continued</p> <ul style="list-style-type: none"> <li>- evolution: aim and meaning: divine Principle, Love</li> </ul>
11-A	<ul style="list-style-type: none"> <li>• recap of II</li> </ul>
11-B	<p>III. The method of divine awareness</p> <ul style="list-style-type: none"> <li>- intellectual and spiritual</li> </ul>
12-A	<p>...continued</p>
12-B	<p>...continued</p> <ul style="list-style-type: none"> <li>- the Christ-spirit</li> <li>- the Mind of Christ</li> </ul>
13-A	<p>...continued</p> <ul style="list-style-type: none"> <li>- the atmosphere of divine Science</li> </ul>
13-B	<ul style="list-style-type: none"> <li>• the language of Spirit (tonality = new tongue)</li> </ul>
14-A	<p>...continued</p>
14-B	<p>IV. The relationship of Science to the sciences</p> <p>...continued</p>

- 
- 14-B CONT.                   – what are the sciences?  
                                   – what is Science  
                                   – the Principle of all principles  
                                   – the impact of Science on all the other sciences
- 15-A                             • the big bang (atomic action is Mind)  
 15-B                             ...continued
- 16-A                             • the equipollence of God  
     ▪ the laws of nature are the laws of Spirit
- V. The Chart
- 16-B                             ...continued  
     ▪ dimensionalism
- 17-A                             – reductionism  
 17-B                             – dimensionalism vs. reductionism (*A Study Aid for the Science of Christian Science*, by Max Kappeler, page 59)
- 18-A                             – general translatability  
 18-B                             – what are the levels?  
                                   – the level of Science itself  
                                   – divine Science
- 19-A                             • absolute Christian Science  
                                   – Christian Science  
                                   – how are the levels holistic?
- 19-B                             ...the levels continued  
                                   – the ascending and descending way
- 20-A                             • the fourfold calculus, history of the development  
 20-B                             ...continued
- 21-A                             – the synonymous terms: their place-value in the model of Being  
                                   • descending way of demonstration – as a system
- VI. Laws: Sc, dSc
- 22-A and 22-B                   ...continued  
                                   W/aCS: X/aCS  
                                   Xty/aCS; Sc/aCS  
                                   W/CS; X/CS  
                                   X/CS: Xty/CS; Sc/CS
- 23-A  
 23-B
- 24-A                             VII. Divine cybernetics  
     ▪ information, the factor behind divine cybernetics
- 24-B                             – the cybernetic nature of the three categories of Being

- 
- |      |   |
|------|---|
| 25-A | – the morphogenetic field ( <i>New Science of Life: The Hypothesis of Formative Causation</i> , by Rupert Sheldrake, © 1981 Saunders of Toronto Ltd.) |
| 25-B | – implications of the morphogenetic field theory  |
|      | ▪ what is going on in the world   |

---

---

ABBREVIATIONS

M, Sp, So, P, Li, T, Lo	= Mind, Spirit, Soul, Principle, Life, Truth, Love.
W, X, Xty, Sc	= Word, Christ, Christianity, Science.
Sc, dSc, aCS, CS Science	= S520cience, divine Science, absolute Christian Science, Christian Science

---

---

REFERENCES

*New Science of Life: The Hypothesis of Formative Causation*, by Rupert Sheldrake, © 1981 Saunders of Toronto Ltd.

*A Study Aid for the Science of Christian Science*, by Max Kappeler, page 59



# The Model of Being and its Universal Laws

## Introduction

- Consciousness determines experience
- The old worldview (The Old Story of Science)
- The new worldview (The New Story of Science)

### A. The fourfold aspect of holistic philosophy

- I. The object of investigation: the whole
- II. The holistic method of investigation: holistic science
  - holistic definition of science
  - elements
  - categories vs. randomness
  - law
  - system vs. linear logic
  - structure/structuralism vs. atomism
  - dimensions/dimensionalism vs. reductionism
  - cybernetics vs. causality
  - evolution/holism
- III. The method of holistic awareness
- IV. Holistic self-intelligence
  - information
  - holistic consciousness
  - divine philosophy (theology; holistic science; divine medicine – problem solving; holistic philosophy)

### B. Christian Science fulfills the fourfold aspect of holistic philosophy.

- I. The object of investigation: God (theology)
- II. The holistic method of investigation: Christ Science
  - Science, divinely defined
  - elements: ideas
  - categories: 3 categories of capitalized terms
  - law: interrelation of holistic categories
  - system: the Model of Being (the Chart)
  - structure and restructuring
  - dimensionalism: hierarchy of structures
  - divine cybernetics

- evolution; aim and meaning: divine Principle, Love
- B. Christian Science fulfills the fourfold aspect of holistic philosophy.  
(continued from previous page)

III. The method of divine awareness

- intellectual and spiritual
- Christ-spirit
- the Mind of Christ
- the language of Spirit (tonality = the new tongue)

IV. The relationship of Science to the sciences

- what are the sciences?
- what is Science?
- the Principle of all principles
- the impact of Science on all the other sciences
- the big bang (atomic action is Mind)
- the equipollence of God
- the laws of nature are the laws of Spirit

# Model of Being

(The Chart)

Science itself	infinite Principle				
	Word	Christ	Christianity	Science	
divine Science	Life	Truth	Love	divine Principle, Love	
absolute Christian Science	Life Truth Love	Truth Life Love	Life Love	Truth Love	
Christian Science	Mind	Principle Life Truth Love Soul Spirit Mind	Principle Mind Soul Spirit Life Truth Love	Principle	
	Spirit			Soul	Soul
	Soul			Principle	Life
	Principle			Spirit	Truth
	Life			Love	Love
	Truth			Principle	Principle
	Love				

**The 7 Synonymous Terms for God (in Word-order):** Mind, Spirit, Soul, Principle, Life, Truth, Love

**The 4-fold Operation of Being:** Word, Christ, Christianity, Science

**The 4 Levels of Spiritual Consciousness:** Science itself, divine Science, absolute Christian Science, Christian Science

## References to the previous matrix: Model of Being “*The Chart*”

### Books by Max Kappeler:

*The Development of the Christian Science Idea and Practice* ©2004, 2<sup>nd</sup> edition. (healing on the levels)  
*The Four Levels of Spiritual Consciousness: Science itself, divine Science, absolute Christian Science, Christian Science*, pp. 117–198 (the place value of the synonyms on *The Chart*..

### Recordings by Max Kappeler:

- A-4: *The Structure-principle of Being*, 1974, Wilmington, DE, hour 21.
- A-5: *A Seminar on the Seven Synonymous Terms for God*, 1975, Wilmington, DE, hours 22–23.
- A-6V: *Syllabus V*, 1980, hours 13–19.
- B-1: *A Survey of the Fundamentals of Christian Science*, hours 5–8, 12.
- B-2 *From Atomistic Thinking to Cybernetic Comprehensive Consciousness*, 1970, Ogunquit, ME, hours 19–20.
- D-1: *The 4 Levels of Science*, 1967/68, London, England, hours 6–9, 13–16.
- D-2: *Divine Cybernetics: the proto-science, the integral Science*, 1969, Braunwald, Switzerland, hours 8–11.
- D-4: *Divine Cybernetics and the Self-operating “Dimensional Laws” of the Once Being, God: Word (Part I), Word (Part II), The Christ (Part III), Christianity (Part IV), Science (Part V)*, 1971/72, New York, hours 5–24.
- E-1: *The Structure of Being and its Universal Laws*, 1973, New York, hours 7–38.
- G-2: *The Science of Being—As I See It Today*, 1970, London, England, hour 17.

### Books by John Doorly: treated mostly in the context of the ascending and descending scales of Science:

- Talks at the Oxford Summer School, 1948*, Vol. II, pp. 38, 157–158.
- Talks at the Oxford Summer School, 1949*, Vol. I, pp. 21–24, 49–51.
- Talks at the Oxford Summer School, 1949*, Vol. II, pp. 268–273 (the story of the one infinite system, including the level of Science itself).
- Talks on the Science of the Bible*, Vol. I, “red book,” pp. 65–69.
- Talks on the Science of the Bible*, Vol. III, “red book,” pp. 282–284.
- Talks on the Science of the Bible*, Vol. VI, “red book,” pp. 207–208.
- Talks on the Science of the Bible*, #58, “blue book,” pp. 9–16.
- Talks on the Science of the Bible*, #59, “blue book,” pp. 4–16 (Christian Science to Science itself to Christian Science).
- Talks on the Science of the Bible*, #61, “blue book,” pp. 3–10, 31–32.
- The Pure Science of Christian Science*, pp. 65–67 (the city foursquare and the city of our God).



**KAPPELER INSTITUTE RECORDINGS**

**ILLUSTRATIVE MATERIAL**

**THE LAW OF THE SELF-EVOLUTION OF UNDERSTANDING  
THROUGH THE IDEA OF CHRISTIAN SCIENCE  
(Tape Code G-7)**

**Max Kappeler**

©1994, 2006, Kappeler Institute for the Science of Being  
All rights reserved



Kappeler Institute Publishing  
P.O. Box 99735  
Seattle, WA 98139-0735  
Tel: (206) 286-1617 • Fax: (206) 286-1675  
E-mail: [mail@kappelerinstitute.org](mailto:mail@kappelerinstitute.org)  
[www.kappelerinstitute.org](http://www.kappelerinstitute.org)  
Division of Kappeler Institute for the Science of Being, USA  
Seattle, WA USA

# Contents

## The Law of the Self-evolution of Understanding Through the Idea of Christian Science

(Tape code: G-7)

©1994, 2006 Kappeler Institute for the Science of Being

AUDIO RECORDING NUMBER/SIDE	SUBJECT
1-A	<b>Introduction</b> <ul style="list-style-type: none"><li>- Science evolves itself from the over-all structure of the textbook:<ul style="list-style-type: none"><li>▪ Word (W): defines what God is</li><li>▪ Christ (X): shows how God helps humanity; shows the relationship between God and man as a saving agent in Being</li><li>▪ Christianity (Xty): gives a new concept of man and the universe</li><li>▪ Science (Sc): introduces “Science” into Christianity</li></ul></li></ul>
1-B	<b>How does Christian Science Evolve?</b> <ul style="list-style-type: none"><li>▪ attitude that enables evolution</li><li>▪ the law that rules in Science to bring forth new insights</li><li>▪ receptivity essential to a paradigm shift: Mrs. Eddy was prepared to receive “this” (her) final revelation for her time</li><li>▪ willingness always to go forward</li></ul> <b>Over-all view of the class: four aspects</b> <ul style="list-style-type: none"><li>▪ W: Mrs. Eddy’s references to the future of Christian Science. Why John W. Doorly alone could see the Science of Christian Science.<ul style="list-style-type: none"><li>- daily contemplation of Scientific Obstetrics and handling of animal magnetism</li></ul></li><li>▪ X: students’ response to the development of the idea of Christian Science since 1866. The Christ-rule that governs evolution.</li><li>▪ Xty: evolution of the idea in the universe</li><li>▪ Sc: as all law converges toward Christian Science we know what the future will be. Mankind will accept Christian Science</li></ul>

- 
- 2-A                    **Textbook authority for the evolution of Christian Science**  
**(I.M. page 1)**
- references through M–Lo:
  - convergence of natural scientists toward the idea of Christian Science: Paul Davies, Stephen Hawking
- 2-B
- M–So
  - P: Instruction will tend toward the spiritual. Under the impact of John W. Doorly’s work in the Science of Christian Science a new consciousness came to birth during the Second World War.
- 3-A
- Li: dSc is the spiritual origin of man, not human parents; therefore, man is a calculus of ideas. The unfolding understanding of Christian Science has caused the paradigm shifts in consciousness and the exponential growth in all fields in this age.
  - T: Healing is only the first article of Christian Science; its primary purpose is to demonstrate divine Principle.
- 3-B
- ...continued
  - Lo: The deep structure of the Textbook is invariable; the surface structure language can be adapted to the age.
- 4-A                    **The law of Science impels paradigm shifts**
- references from Mary Baker Eddy, John W. Doorly, and Caclav Havel on the future development of consciousness
- 4-B
- practice of “Scientific Obstetrics” as the first step: **(I.M. page 2)**
    - M–Lo; W–Sc
- 5-A                    **The law of the self-evolution of understanding through Christian Science as shown in the 16 chapters of *Science and Health***  
**(I.M. page 3 and 4)**
- Word-chapters
    - *Prayer*
    - *Atonement and Eucharist*
    - *Marriage*
    - *Christian Science versus Spiritualism*
- 5-B
- 6-A
- Christ-chapters
    - *Animal Magnetism Unmasked*
    - *Science, Theology, and Medicine*
- 6-B
- ...continued
  - *Physiology*
  - *Footsteps of Truth*
- 7A
- recap of the first eight chapters **(I.M. page 4)**
  - Christianity-chapters
    - *Creation*
    - *Science of Being*



- 
- 7-B                   – *Science of Being*, continued
  - *Some Objections Answered*
  - 8-A                   – *Christian Science Practice*
  - Science-chapters
    - *Teaching*
    - *Recapitulation*
  - 8-B                   – *Genesis*
  - the lay-out of Chapter XVI, *The Apocalypse* **(I.M. page 5)**
    - the development of the Science-levels
      - ♦ level of CS
        - ...continued
      - ♦ level of aCS **(I.M. page 5)**
    - level of dSc (our state of consciousness determines if we see the old or the new heaven) quantum theory says matter can be seen in two ways: as a particle or a wave, depending on perspective
      - ♦ level of dSc, continued
      - ...continued
  - 9-A
  - 9-B
  - 10-A
  - 10-B
  - 11-A

Note: The acme of this Science as the Bible reveals it is shown in *The Apocalypse*. Jesus, St. John, Mary Baker Eddy, and those who followed saw that evolution is not blind to the future. Its aim is Love.

**Matrix Form of the Law of Self-evolution of understanding through  
*Science and Health with Key to the Scriptures*, by Mary Baker Eddy  
(I.M. page 6)**

- 11-B                   ▪ Word-vertical
  - ...continued
  - Christ-vertical, Christianity-vertical, and Science-vertical
  - for proof that the Matrix is correct, read the i-index horizontally and the j-index vertically.
- 12-A                   **The Christ-law is working individually, collectively, universally,  
cosmologically in a chain of being through the 16 Textbook chapters.**
  - impact of the Christ on CS students **(I.M. page 7)**
    - 1866–1900—development of understanding in the 19<sup>th</sup> century:
      - ♦ the Edward Kimball period: Principle must be understood through its ideas
      - ♦ Bicknell Young period: oneness of Being
      - ♦ John W. Doorly and post-Doorly period: Science of CS
      - ♦ Young and Doorly periods (continued)
      - ♦ Doorly period (continued). Once we know the tonality of the categories we accept revelation.
- 12-B
- 13-A
- 13-B

- 14-A
- ◆ Doorly period (continued). John W. Dooley was the first to interpret the Bible correctly. He saw the “key” in *S&H* (the 7 and the 4) which enabled him to see the deep structure of the Bible. Mrs. Eddy had overruled 2000 years of Bible interpretation and gave the “key” in her Textbook.

Note: Relevance of the Bible to the present day; the deep structure law is forever applicable though the surface structure changes (the symbols, the language).

- ◆ We reach the deep structure in revealed texts by listening to the tonality, the subject, and check to see if the breaks are in an order and tell a coherent story.
  - ◆ Doorly saw the correlation between the structure of the Bible and the Textbook and, therefore, fulfilled Mary Baker Eddy’s prophecy.
  - ◆ A new paraphrase from the world of letters evolves. (Mis. 364:4).
- 14-B
- ◆ Mary Baker Eddy wrote *Science and Health with Key to the Scriptures*, but did not explain its structure.
  - ◆ John W. Doorly explained the structure of *S&H*, going his own way, not remaining at the standpoint of predecessors Young and Kimball.
  - ◆ We too must go on, sticking to the tonality, never stalling, because Science evolves itself out of its own fundamentals.

### Matrices

- The Textbook is a fundamental matrix from which we can, through the divine infinite calculus, build infinite matrices, a matrix sense of any subject.
  - Our method is to listen to the tonality of the categories to see what the subject is.
- 15-A
- ...continued

### Truth and Scientific Truth; i.e., Truth in its matrix form (See *Truth and Scientific Truth*, booklet, by Max Kappeler)

- 15-B
- ...continued
- Science evolves itself from the matrix form which has “the seed within itself.” The relationships of categories from which laws can be formed; i.e., the laws of the Prophets, the Epistles, the Model of Being
    - All problems can be handled through the laws of the Model of Being.
    - By grace we have the ontological categories of Being for the first time in human history. The fourfold structure of Being impels understanding to go forward.

16-A

**Comparison: the law of the self-evolution of understanding through the idea of Christian Science as seen in *Scientific Obstetrics*, the Textbook chapters, and the history of the development of understanding (I.M. page 7)**

- reading horizontally through comparison of the three

**Historical sequence of study: interpreting the Bible, the Textbook, and not the universe:**

- We had left the universe to natural scientists, but the one Being includes the universe; therefore, we must be able to interpret the universe correctly.
- Understanding has developed from the 2 dimensional to the 3<sup>rd</sup> and 4<sup>th</sup> dimensions:
  - 2 dimensions up to the Renaissance—length and breadth of flatland
  - 3 dimensions—adding perspective of height
  - 4<sup>th</sup> dimension—with Einstein’s space/time continuum

16-B

- ...continued
- Alan H. Guth of the Massachusetts Institute of Technology, author of *The Inflationary Universe: The Quest for a New Theory of Cosmic Origins*, says that there are 11 dimensions
- Mary Baker Eddy speaks of the 4<sup>th</sup> dimension of Spirit
- Contemporary scientists say that which falls into a black-hole disappears, so we have a zero dimensional universe; therefore, no time or space.
- There may be a multitude of universes
- The 7<sup>th</sup> 1000-year period will impel us into a new concept of the universe

**There is only one Principle of the universe as shown in the Textbook (I.M. page 8)**

- Natural science is converging to this concept, and it is a new field of investigation in Christian Science.
- Principle
- forces
- ...continued **(I.M. page 8 and 9)**
- only one power: the intelligence of divine Mind
- motion of the universe
- astronomical order
- cause and effect is one—only one Mind
- Is there purpose and meaning in evolution?

17-A

17-B

**Over-all view among natural scientists in regard to reality**

- Jean Guitton, the French Christian philosopher, in his interview with two nuclear Scientists:
- how the thinking of natural scientists is converging toward Christian philosophy:
  - on the Big Bang theory
  - on symmetry as the first cause
  - on the Logos as the field of Spirit, the field of intelligence, which is ordered
  - Physicists refer to philosophy until they see the Logos as St. John saw it.
  - Both natural scientists and Christian Scientists claim 15 universal, cosmological constants.
  - The universe exists in exactness “to the 62<sup>nd</sup> decimal point,” exactly balanced; otherwise, it would explode or implode. Guth sees this balance.
  - definition of the Logos: “An intelligent, rational element that governs the cosmos, regulates, animates, and operates it, so that there is no chaos, but order”
  - St. John and Mrs. Eddy start with the Logos

18-A

**What is matter?**

- Natural scientists’ explanations that matter is mostly empty space converge toward:
  - Mrs. Eddy’s views that the universe consists of Spirit, not matter
    - ♦ with 15 constants, we can explain the universe
    - ♦ The scientists describe a void.
    - ♦ Mrs. Eddy says Mind is all, mortal mind is nothing; we tread on forces which are non-local fields.
    - ♦ Parts do not exist, so we have only vibrations and oscillations
    - ♦ The laws of Christian Science are the laws of the universe.
    - ♦ Mrs. Eddy: divine metaphysics resolves “*things into thoughts*”. (*S&H 123:14*)
  - Natural scientists turn to Plato, who explained the only reality to be the realm of ideas.
  - Mrs. Eddy: “divine Science...excludes matter,” resolves things into ideas (*S&H 123:12*)
  - Natural scientists see ideas as the “global invariance of symmetry”.

18-B

18-B, cont.

- Mrs. Eddy: the form of man “is wholly symmetrical”. (Mis. 167:6)
  - ♦ symmetry is building up the universe, which is made of fifteen constants, not just nothingness
- Sir James Jeans: the universe resembles more a great thought than a great machine
- Max Plank: the invisible immortal Spirit is the Truth
- Mrs. Eddy: “Laws of nature are the laws of Spirit,” (*S&H* 183:19) and Science explains that nature; Underlying the cosmos, is cosmic law which constitutes the equipoise of Being.
- Weisacker: “I see that all is spirit, the Holy Spirit, though I devoted my life to the study of matter.”

**The trend of thinkers towards Christian Science**

- Classical science started with the Renaissance; then with DesCartes and Newton in the age of rationalism where the subjective view is left out
- The new concept of science includes both objectivity and subjectivity
- Mary Baker Eddy: The overriding synonym in *Science and Health with Key to the Scriptures* is Soul, where subject and object is one.
- Quantum theory brings in the subjective/objective, where something can be one thing and at the same time something else; i.e., a particle or a wave, depending on the observer’s state of consciousness. Physicist John A. Wheeler, co-author of *Spacetime Physics* (with Edwin F. Taylor) elaborated this theory.
- Classical science is also deterministic.
- Divine Science has its own purpose and does not obey our desires.

19-A

- Wheeler we live in a “participatory” universe, as we are God-being. There is oneness of the subjective/objective.
- Chaper XVI, *The Apocalypse* has the summary answer to everything.
- This paradigm shift from the material to the spiritual world view demands a total change of consciousness. It is as great as the shift from the Ptolemaic to the Copernican view, a shift to spiritual monism.
- Mrs. Eddy: “Mind is All-in-all”. (Mis. 183:8)
- *Science and Health with Key to the Scriptures* is a Textbook for today, but we need to think if it as the Model of Being.

19-A, cont.

**Summary of the new reality according to natural scientists**

1. It is spirit, not matter.
2. It is more a thought than a machine.
3. Spirit and the world are one and the same reality.
4. We cannot explain matter as such, but only explain it away.
5. Nothing that we perceive is reality.
6. Material reality is a deception, a swarm of imagination.
7. The human mind perceives only what it believes to be there.
8. The real is inaccessible, it is veiled, forever imperceptible, and the enigmas is the enigma of Spirit.
9. Mrs. Eddy: only the revelation of Truth can resolve the enigma of mortal existence (See *S&H* 70:1).
10. There is a transcendental reality, a reality of Spirit, and that reality is order.
11. That reality is not based on material dimensions; there are infinite dimensions.
12. This reality is a result of a transcendental order.
13. Reality is stranger than we think. Beyond the material universe exists a maximum of information; one transcendental cause of all causes (divine Mind).
14. The old materialism is no longer valid today. We have made the step leading through science to God, to reality. *Science and Health with Key to the Scriptures*, “The earth will help the woman” (*S&H* 570:22).
15. The universe is intelligent; the omnipresence of that reality operates in every part of the universe. Mrs. Eddy: every idea reflects the infinite. Sir John Carew Eccles (Nobel Prize in Physiology 1963): “the brain does not think.” Deepak Chopra: “The universe thinks, not the brain.”
  - This intelligence transcends all that exists on our level of reality, which is too limited.

**References to the “new reality” in *Science and Health***

**Mind**

- Mrs. Eddy refers to Genesis 2:4, 5 to show that Mind is the cause of all, growth is the eternal mandate of Mind. (*S&H* 520:23, 212:23, 191:21, 125:30).
- The first record of creation in the Bible shows the realm of reality. Only then the earth can shadow forth the counterfeit, as in the second record of creation.

19-A, cont.

### **Spirit**

- We are aware of the evolution from a material to a spiritual consciousness, not simply becoming more ethical or moral
- Evolution is something that transcends human beings.
- Man has appeared very recently in history.
- Evolution is an innovative process from lower to higher structures of order.
- What is the man of tomorrow? We are the transitional link to the man of the future until we see man's origin in divine Science.
- We are the divine infinite calculus, the city of God.
- Jean Guittou, philosopher and theologian: Spirit is the spiritual Principle of the universe.
- Evolution is directed toward Spirit. The world will be spiritualized.
- The cosmos melts into a spiritual Principle.
- "...one Principle and its infinite idea." (*S&H* 112:16)
- Max Plank: "There is no matter as such, it exists only as a force ... we have to accept that behind this force exists a conscious intelligent Spirit."

### **Natural scientists seek a meta-reality, a reality that is a network of information, an information universe**

19-B

- Mary Baker Eddy: order does not need a material medium to express itself, to evolve itself (See *S&H* 72:27).
- Jean Guittou: "The universe is an information chart ... an enormous information matrix."
- So we see that Christian Science is the universe, and for natural scientists the future will bring the discovery of the cosmic information source. They call it, "the gauging field."
- The Model of Being is our gauging field wherein there is no dualism.
- Quantum theory tells us we have to see eternal Truth, as that which changes our concept of the universe.

20-A

...continued references on matter/Spirit

- ♦ "...is a stone spiritual?" (*Mis.* 27:27-2) The answer depends on the state of consciousness from which it is observed.
- ♦ "St. John spiritually discovered and revealed the sum total of transcendentalism." (*Mis.* 30:8)

20-A, cont.

**Is the universe ordered or disordered?**

- The Model of Being shows reality is in perfect structural equilibrium and order. Even at the time of the Big Bang there was perfect symmetry. It is dynamic, with the law of cybernetics within it. Everything flows in perfect equilibrium, including evolution.

20-B

- Crises happen before a higher understanding appears
- Self-organization is spontaneous and brings forth a higher order.
- The universe maintains its equilibrium and order through all levels to human thinking. The Model of Being with its levels is an interpretation of reality. All stems from the spiritual Principle of order.

**Our future development is to see meta-realism, divine metaphysics, a synthesis of realism/idealism**

- and know the laws of the Model of Being which order reality

**Some conclusions from Jean Guitton (French Christian philosopher)**

21-A

- He speaks of the telefinalistic plan of Love. The universe knew that the time had come for man with consciousness to appear.
- Guitton on 3 great paradigm shifts among physicists:
  1. movement: Galileo, Kepler, Newton
  2. quantum theory, law of changes, cybernetic laws at the turn of the 20<sup>th</sup> Century
  3. physics of meaning or semantic physics which give rise to the language of Spirit in its Science. Meta-realism with its 15 ontological constants constitute an information network as in Christian Science.
- Stephen Hawking seeks the "Theory of Everything," a consistent model. (We have the Model of Being).

**Law: definitions**

**(I.M. page 11)**

21-B

- order, process, prediction, relationship, structure
- chance, wonder, miracle, chaos
- origin of laws
- Commandments of the Bible are humanly conceived
- The laws of nature are abstract, universal; independent of people.
- the laws of knowledge which include relationships of ideas with progression from linear facts to system
- laws of restructuring in matrices
- laws of wholeness
- laws of cybernetics



- 
- 22-A
- laws including the subjective/objective
  - Mary Baker Eddy's law, "God is All." (*S&H* 532:24)
  - recap of Law: Law consists of facts in their right relationships.
  - *S&H* states that there are laws, but does not say what they are.
    - ♦ *S&H* has references to 1<sup>st</sup>, 2<sup>nd</sup>, and 3<sup>rd</sup> degree laws
  - Only by going to the deep structure of *S&H* can we find what the laws are:
    - John Doorly did not explain the laws
    - the idea of laws developed slowly, first in Max Kappeler's Prophet book, *The Minor Prophets in the Light of Christian Science*. These laws are applicable today.
- 22-B
- impact of the cybernetic idea on all aspects of life: input, process, outcome, feedback on each level in an universal self-organizing, self-operating law at work in both the material and spiritual fields
  - How laws can be developed from the spiritual order of a subject through the 16 Chapters of *Science and Health with Key to the Scriptures*.
- 23-A                    **Law in the Textbook, as seen in matrix form**                    **(I.M.: page 12)**
- reading the laws of the chapters vertically
  - seeing the common denominator of the verticals
  - the Word (W) and the Christ (X) verticals
- 23-B
- the Christianity (Xty) vertical
  - the Science (Sc) vertical to Genesis
- 24-A
- Genesis to Apocalypse
    - ♦ common denominator for the Sc-vertical
    - ♦ checking the spiritual order; reading the indices "i" and "j", representing absolute Christian Science (aCS) and Christian Science (CS).
    - ♦ reading the diagonal
- 24-B                    **The Model of Being**                    **(I.M.: page 10)**
- interpreting the Chart of the one Being with its 3 categories interwoven: the synonymous terms for God, the fourfold calculus and the levels.
  - To understand the Textbook we must understand the laws of the Model of Being.
    - ♦ John Doorly showed the system in the Textbook
    - ♦ Max Kappeler has shown the method of understanding it. (See *A Study Aid for the Science of Christian Science*, Max Kappeler, page 78–95).

- 25-A                    **The Laws of the Model of Being**                    **(I.M.: page 13)**
- the law of Science itself: God's relationship to Himself
    - ♦ elaboration of the law, including the rule of thumb: M/M–M/Lo and L/M–Lo/Lo.
- 25-B                    ♦ The law of Science itself is the law of infinite self-reflection. There are other laws to govern the other levels of consciousness.
- The Law of divine Science which encircles and operates the universe has to do with the oneness of Principle and idea.**
- explanation of the place values of the synonyms on the dSc level
  - elaboration of the law
- 26-A                    - brief review of the laws of Sc and dSc
- The Law of absolute Christian Science (law of divine spontaneity): the relationship of Principle to specific ideas as:**
- ♦ W: the law of divine impulsion
  - ♦ X: the law of divine individualization
  - ♦ Xty: the law of externalization
- 26-B                    ♦ Sc: the law of prestabilized perfection
- ♦ practice on the level of aCS
- 27-A                    **The Law of Christian Science: relationship between Truth and error, through:**
- ♦ W: the law of creativity
  - ♦ X: the law of translation and retranslation
- 27-B                    ♦ Xty: the law of reflection
- ♦ Sc: the law of structured understanding
  - ♦ Natural scientists see that beyond the material universe is the spiritual universe. They call it the information matrix, cosmic information; a universe that thinks versus people thinking; the universe is divine consciousness.

**Conclusion:**

We have considered a world-view that weds together what we humanly believe is matter with what we divinely perceive as Spirit. Seen correctly this resolves duality. In the new century we will investigate the spiritual reality; therefore, we have to know the laws reigning in the spiritual realm. Understanding the laws, we have the same Mind as God.

---

---

ABBREVIATIONS

M, Sp, So, P, Li, T, Lo	= Mind, Spirit, Soul, Principle, Life, Truth, Love
W, X, Xty, Sc	= Word, Christ, Christianity, Science
Sc, dSc, aCS, CS	= Science, divine Science, absolute Christian Science, Christian Science
I.M.	= Illustrative Material
S.A.	= <i>A Study Aid for the Science of Christian Science</i> , by Max Kappeler
S&H	= <i>Science and Health with Key to the Scriptures</i> , by Mary Baker Eddy
M/M–M/Lo	= Mind as Mind through the 7 synonyms to Mind as Love
Mis.	= <i>Miscellaneous Writings</i> , by Mary Baker Eddy

**USA Summer Schools 1994  
on  
The Science of Christian Science**

---

**The law of the self-evolution of understanding  
through the idea of Christian Science**

---

**Max Kappeler**

Study material for class work

**USA Summer Schools 1994  
on  
The Science of Christian Science**

---

**The law of the self-evolution of understanding  
through the idea of Christian Science**

---

**Max Kappeler**



Kappeler Institute Publishing  
Wilmington, DE, U.S.A.

## Contents

The future unfoldment of Christian Science	1
Scientific obstetrics (S&H 463:5-20)	2
The law of the self-evolution of understanding through the idea of Christian Science (shown in the 16 chapters of the Textbook)	3
- the lay-out of the chapter 'The Apocalypse'	5
- shown in the matrix-form	6
- comparison of 'scientific obstetrics' - Textbook-chapters - development of 'understanding' in the Christian Science movement	7
There is only one Principle of the universe	8
The 'Model of Being'	10
Law: - definitions	11
- 'law' in the Textbook (matrix-form)	12
- the laws of the 'Model of Being'	13
- the Law of Being	14
The services of the Kappeler Institute	15
Information Centers	15

## The future unfoldment of Christian Science

- Mind:** “Each successive period of progress is a period more humane and spiritual. The only logical conclusion is that all is Mind and its manifestation, from the rolling of worlds, in the most subtle ether, to a potatopatch.” Mis. 26:4-8  
See also: S&H 108:30-109:6
- Spirit:** “Spiritual evolution alone is worthy of the exercise of divine power.”  
S&H 135:9-10  
See also: No. 45:25-27; S&H 547:25-27; 371:22-25; 449:3-6; 152:8-9
- Soul:** “When will the ages understand the one Ego, and realize only one God, one Mind or intelligence?” S&H 204:20-22  
See also: S&H 70:7-9
- Principle:** “A higher discovery (M.H.)” “. . .the divine Mind produces in man health, harmony, and immortality. Gradually this evidence will gather momentum and clearness, until it reaches its culmination of scientific statement and proof.” S&H 380:22-28  
See also: 449:16(;)-18
- Life:** “The time cometh when the spiritual origin of man, the divine Science which ushered Jesus into human presence, will be understood and demonstrated.” S&H 325:26  
See also: S&H: 566:9-11; 55:15-22; Mis. 61:4-6; 82:20-21
- Truth:** “Healing physical sickness is the smallest part of Christian Science. It is only the bugle-call to thought and action, in the higher range of infinite goodness.” Rud. 2:23-25  
See also: S&H 145:31-146:2; 51:21-23; 150:4-6; 150:8-17; 144:27-29
- Love:** “Through many generations human beliefs will be attaining divine conceptions, and the immortal and perfect model of God’s creation will finally be seen as the only true conception of being.” S&H 260:8-12
- Jesus to St. John:**  
“. . .the Father shall give you another Comforter . . .the Comforter shall teach you all things . . . and he will show you things to come . . .” Jh. 14:16, 26; 16:13
- Christian Science Textbook:**  
“Centuries will intervene before the statement of the inexhaustible topics of that book become sufficiently understood to be absolutely demonstrated.”  
Mis. 92:4-6  
See also: Mis. 317:14-18; Un. 5:28-7:26

## Scientific Obstetrics

(S & H 463:5-20)

<b>WORD</b>	<i>From pure thoughts to ideas</i> Teacher and student should also be familiar with the obstetrics taught by this Science.	<b>MIND</b>
	To attend properly the birth of the new child, or divine idea, you should so detach mortal thought from its material conceptions, that the birth will be natural and safe.	<b>SPIRIT</b>  <b>SOUL</b>
<b>CHRIST</b>	<i>The power of the idea excludes error</i> Though gathering new energy, this idea cannot injure its useful surroundings in the travail of spiritual birth.	<b>PRINCIPLE</b>
	A spiritual idea has not a single element of error, and this truth removes properly whatever is offensive.	<b>LIFE</b>
<b>CHRISTIANITY</b>	<i>The bigness of the idea</i> The new idea, conceived and born of Truth and Love, is clad in white garments. Its beginning will be meek, its growth sturdy, and its maturity undecaying.	<b>TRUTH</b>
<b>SCIENCE</b>	<i>The synonym for God alone is Being (only the synonym for God)</i> When this new birth takes place, the Christian Science infant is born of the Spirit, born of God, and can cause the mother no more suffering. By this we know that Truth is here and has fulfilled its perfect work.	<b>LOVE</b>



# The law of the self-evolution of understanding through the idea of Christian Science

---

(shown in the 16 chapters of the Textbook)

## I. The Word-chapters

Prayer: *good human qualities*

- desire, striving, motive

Atonement and Eucharist: *to lay down the mortal sense*

- to rise above material sense

Marriage: *during the transitional phase:*

*to subject ourselves to moral issues*

- concessions to material methods
- mutuality
- keeping moral obligations
- culturing human qualities
- culturing a higher sense

Christian Science versus Spiritualism:

*ideas taking the place of thoughts*

- ideas are the identities of being
- ideas constitute reality
- no mingling of Spirit/matter

good thoughts leading  
to ideas



## II. The Christ-chapters

Animal Magnetism Unmasked: *what is good,  
and what is evil?*

- reality is good
- evil is a suppositional lie
- scientific thoughts pass from God to man

Science, Theology, Medicine: *in Science we  
reason from God*

- Mind is All; matter is nothing
- Truth is a revelation
- Science relates to Mind

Physiology: *to leave all for the Christ-standpoint*

- to take only the Christ-standpoint
- in Thy light shall we see light

Footsteps of Truth: *nothing can stop the  
advancement of Christian Science*

- Science marches on
- slow development towards perfection
- calamities will abound
- absolute Christian Science may not be achieved  
prior to the change called death

the power of the idea  
bringing good thoughts



### III. The Christianity-chapters

Creation: *eternal Truth is changing the universe*

- chaos changing into order
- ideas develop forever
- ideas rise higher and higher
- it takes generations

Science of Being: *brings to light many useful wonders*

- thought rises to a metaphysical basis
- the finite gives place to the infinite
- Christian Science will be finally accepted

Some Objections Answered: *the higher meaning of Christian Science cannot be understood at once*

- we must first grow into the stature of manhood in Jesus Christ

Christian Science Practice: *reestablishing the normality of mortal mind*

- the Science of physical harmony
- corporeal health is not spiritual health
- healing is a bugle-call for a higher range of goodness

**ideas are in God; the universe and man are God-ideas**



### IV. The Science-chapters

Teaching Christian Science: *receptivity for spiritual unfoldment of understanding*

- teaching is more difficult than healing
- more than a grain of Christian Science is necessary
- mental anatomy: love
- scientific obstetrics

Recapitulation: *scientific metaphysics*

- scientific systematics

Genesis: *spiritual evolution leads to finer complexity*

- ascending order of the form of understanding
- ordered dissolution of error

The Apocalypse: *the unfoldment of the levels of Science*

- the level of Christian Science
- the level of absolute Christian Science
- the level of divine Science

**understanding the cybernetics of the idea-holism**



## **The lay-out of the chapter ‘The Apocalypse’**

---

### **The development of the Science-levels**

#### **Level of Christian Science:**

- angel:
  - came down from heaven
  - clothed with a cloud
  - in his hand a little book open
  
- woman:
  - in heaven
  - clothed with the sun
  - being with child
  - great red dragon
  - child was caught up unto God and to His throne
  - stately Science pauses not; leading to divine heights
  - war in heaven: Michael/Gabriel
  - the earth helped the woman: the idea will be understood  
: matter must disappear

#### **Level of absolute Christian Science:**

- new heaven and earth; there was no more sea
  - matter and spirit: states and stages of consciousness
  - cessation of error
  - a present possibility
  
- a foretaste of absolute Christian Science
  - there will be no more pain
  - all tears will be wiped away

#### **Level of divine Science:**

- angel with seven vials full of the seven last plagues
  - sum total of human misery
  - full compensation in the law of Love
  - physical plagues will be destroyed forever
  
- the bride, the Lamb’s wife
  - (Jesus: the coincidence of the human and divine)
  - woman: the coincidence of God and man as the divine Principle and divine idea
  
- New Jerusalem: the Lamb’s bride
  - city foursquare; coming down from heaven
  - light and glory of divine Science; wholly spiritual
  - no night there
  
- no temple (body) therein
  - the material sense of personality yields to the incorporeal sense of God and man as the infinite Principle and infinite idea
  - there is no impediment to eternal bliss - to the perfectibility of God’s creation
  - ‘nothing can enter. . . which defileth or maketh a lie’
  
- “the acme of this Science as the Bible reveals it”

## The law of the self-evolution of understanding through the idea of Christian Science

	WORD	CHRIST	CHRISTIANITY	SCIENCE
Christian Science  scientific metaphysics	good thoughts leading to ideas	the power of the idea bringing good thoughts	ideas are in God; the universe and man are God-ideas	understanding the cybernetics of the idea-holism
<b>WORD</b>  proposition	<b>PRAYER</b>  good human qualities	<b>ANIMAL MAGNETISM UNMASKED</b>  the distinction of what is good and what is evil comes to light	<b>CREATION</b>  eternal Truth is changing the universe	<b>TEACHING CHRISTIAN SCIENCE</b>  receptivity for spiritual unfolding of understanding
<b>CHRIST</b>  to submit all to the idea	<b>ATONEMENT AND EUCHARIST</b>  to lay down the mortal senses; rising above material sense	<b>SCIENCE, THEOLOGY, MEDICINE</b>  in Science we reason from God	<b>SCIENCE OF BEING</b>  brings to light many useful wonders	<b>RECAPITULATION</b>  scientific metaphysics
<b>CHRISTIANITY</b>  to let the spiritual in us take the place of the material	<b>MARRIAGE</b>  during the transitional phase: to subject ourselves to moral issues	<b>PHYSIOLOGY</b>  to leave all for the Christ - standpoint	<b>SOME OBJECTIONS ANSWERED</b>  the higher meaning of Christian Science cannot be understood at once	<b>GENESIS</b>  spiritual evolution leads to finer complexity
<b>SCIENCE</b>  a spiritually scientific consciousness establishes itself in us	<b>CHRISTIAN SCIENCE VERSUS SPIRITUALISM</b>  ideas take the place of thoughts	<b>FOOTSTEPS OF TRUTH</b>  nothing can stop the advancement of Christian Science	<b>CHRISTIAN SCIENCE PRACTICE</b>  reestablishing health, the normality of mortal mind	<b>THE APOCALYPSE</b>  the unfolding of the levels of Science

## Comparison: The law of the self-evolution of understanding through the idea of Christian Science

	“Scientific Obstetrics”	Textbook-chapters	Development of ‘Understanding’
<b>WORD</b>	<p><i>from pure thoughts to “idea”</i></p> <ul style="list-style-type: none"> <li>— detach mortal thought from its material conceptions</li> <li>— the birth of the new child</li> </ul>	<p><i>from good thoughts to idea</i></p> <ol style="list-style-type: none"> <li>1. good human qualities</li> <li>2. to lay down the mortal sense; rising above material sense</li> <li>3. subjecting ourselves to moral issues</li> <li>4. ideas take the place of thoughts                             <ul style="list-style-type: none"> <li>— ideas constitute reality</li> </ul> </li> </ol>	<p>in the 19th century</p> <p><i>from good thinking to “idea”</i></p> <ul style="list-style-type: none"> <li>— good thoughts</li> <li>— love for God and mankind</li> <li>— arguments</li> <li>— affirmations and denials</li> </ul>
<b>CHRIST</b>	<p><i>the power of the idea excludes error</i></p> <ul style="list-style-type: none"> <li>— the working of the idea</li> <li>— the idea has not a single element of error</li> </ul>	<p><i>the power of the idea bringing good thoughts removes error</i></p> <ol style="list-style-type: none"> <li>5. what is good and what is evil?</li> <li>6. Science reasons from God</li> <li>7. to leave all for the Christ-standpoint</li> <li>8. nothing can stop the advancement of Christian Science</li> </ol>	<p>Kimball-period</p> <p><i>Principle must be understood through its ideas</i></p> <ul style="list-style-type: none"> <li>— ideas in place of thoughts</li> <li>— relation between ideas and material things</li> </ul>
<b>CHRIST- IANITY</b>	<p><i>the bigness of the idea</i></p> <ul style="list-style-type: none"> <li>— ideas are in the synonyms for God</li> <li>— idea is clad in white garments</li> </ul>	<p><i>ideas are in God (7 synonyms)</i></p> <ol style="list-style-type: none"> <li>9. eternal Truth is changing the universe</li> <li>10. brings to light many useful wonders</li> <li>11. the higher meaning of C.S. cannot be understood at once</li> <li>12. reestablishing health, the normality of mortal mind</li> </ol>	<p>Bicknell Young-period</p> <p><i>oneness of being</i></p> <ul style="list-style-type: none"> <li>— universe of ideas</li> <li>— oneness of ideas</li> <li>— Principle must interpret the universe</li> </ul>
<b>SCIENCE</b>	<p><i>alone the synonyms for God are Being</i></p> <ul style="list-style-type: none"> <li>— only synonyms for God</li> <li>— perfection</li> </ul>	<p><i>understanding divine cybernetics</i></p> <ol style="list-style-type: none"> <li>13. receptivity for spiritual unfoldment of understanding</li> <li>14. scientific metaphysics</li> <li>15. spiritual evolution leads to finer complexity</li> <li>16. unfoldment of Science-levels</li> </ol>	<p>Doorly and post-Doorly-period</p> <p><i>Science of Christian Science</i></p> <ul style="list-style-type: none"> <li>— categories and structure</li> <li>— matrix; model of Being</li> <li>— oneness of Being</li> <li>— laws of Being; divine cybernetics</li> </ul>

## There is only one Principle of the universe

- Principle:*
- *From: The First Church of Christ, Scientist and Miscellany (in the article on 'capitalization'), 226:6-16:*  
"What are termed in common speech the principle of harmonious vibration, the principle of conservation of number in geometry, the principle of the inclined plane in mechanics, etc., are but an effect of one universal cause, - an emanation of the one divine intelligent Principle that holds the earth in its orbit by evolved spiritual power, the commands the waves and the winds, that marks the sparrow's fall, and that governs all from the infinitesimal to the infinite, - namely, God. Withdraw God, divine Principle, from man and the universe, and man and the universe would no longer exist."
  - *From: Miscellaneous Writings, 26:4-8:*  
"Each successive period of progress is a period more humane and spiritual. The only logical conclusion is that all is Mind and its manifestation, from the rolling of worlds, in the most subtle ether, to a potatopatch."
  - *From: Science and Health, 257:18-21:*  
". . . infinite Principle, - in other words, divine Love, - is the father of the rain, 'who hath begotten the drops of dew', who bringeth 'forth Mazzaroth in his season', and guideth 'Arcturus with his sons.'"
- Forces:*
- *From: Science and Health, 124:20-23:*  
"Adhesion, cohesion, and attraction are properties of Mind. They belong to divine Principle, and support the equipoise of that thought-force, which launched the earth in its orbit and said to the proud wave, 'Thus far and no farther.'"
  - *From: Science and Health, 124:26:31:*  
"We tread on forces. Withdraw them, and creation must collapse. Human knowledge calls them forces of matter; but divine Science declares that they belong wholly to divine Mind, are inherent in this Mind, and so restores them to their rightful home and classification."
- Only one power: the intelligence of divine Mind*
- *From: Science and Health, 170:7-13:*  
"Only by understanding that there is but one power, - not two powers, matter and Mind, - are scientific and logical conclusions reached. Few deny the hypothesis that intelligence, apart from man and matter, governs the universe; and it is generally admitted that this intelligence is the eternal Mind or divine Principle, Love."
  - *From: Science and Health, 209:10-11:*  
"The world would collapse without Mind, without the intelligence which holds the winds in its grasp."

*Motion of the universe:*

- *From: Science and Health, 90:7-8:*  
“The earth’s motion and position are sustained by Mind alone.”
  
- *From: Science and Health, 240:14-17:*  
“Mind is perpetual motion. . . . The rotations and revolutions of the universe of Mind go on eternally.”

*Astronomical Order:*

- *From: Science and Health, 121:28-32:*  
“As thus indicated, astronomical order imitates the action of divine Principle; and the universe, the reflection of God, is thus brought nearer the spiritual fact, and is allied to divine Science as displayed in the everlasting government of the universe.”
  
- *From: Miscellaneous Writings, 23:20-21:*  
“The universe, including man, is not a result of atomic action, material force or energy; it is not organized dust.”
  
- *From: miscellaneous Writings, 190:1:*  
“Atomic action is Mind, not matter.”
  
- *From: Miscellaneous Writings, 185:27-28:*  
“And so it is written, The first man Adam was made a living soul; the last Adam was made a quickening spirit. - 1 Cor. xv. 45.”

*Cause and effect is one - only one Mind:*

- *From: Miscellaneous Writings, 173:12:*  
“Mind is its own great cause and effect.”
  
- *From: Science and Health, 143:26-31:*  
“Mind is the grand creator, and there can be no power except that which is derived from Mind. If Mind was first chronologically, is first potentially, and must be first eternally, then give to Mind the glory, honor, dominion, and power everlastingly due its holy name.”

**The Model of Being**

		infinite Principle			
		Word	Christ	Christianity	Science
Science itself					
divine Science		Life	Truth	Love	divine Principle, Love
absolute Christian Science		Life Truth Love	Truth Life Love	Life Love	Truth Love
Christian Science		Mind Spirit Soul Principle Life Truth Love	Principle Life Truth Love Soul Spirit Mind	Principle Mind Soul Spirit Life Truth Love	Principle Soul : Life Spirit : Truth Mind : Love Principle



## **LAW** (definitions)

- order:**
- a general statement describing an invariable order or regularity that exists under certain specific conditions (Dictionary of Philosophy)
  - a statement of an order or relationship of phenomena that so far as it is known is invariable under the given conditions; . . . (Webster)
  - order is heaven's first law (Pope)
- process:**
- a firm principle determining the behavior or process of something (Duden)
  - an ordering rule prescribing that which has to happen; an ordering rule immanent in a process or in being (Brockhaus)
  - a law describes that which is; in natural science: a universal rule for the behavior of a process (Apel-Lutz)
- prediction:**
- a principle based on the predictable consequences of an act, condition, etc. (Random House Dictionary)
- relationship, structure:**
- a rule, a principle, or convention regarded as governing the structure or the relationship of an element in the structure of something (Random House Dictionary)
  - laws are relations in a mental structure or theory (Bertalanffy)
  - law is defined today as a 'structural principle' (Schlegel)
- chance, wonder, miracle, chaos:**
- 'chance' is a law of higher order (Köstler)
  - 'wonder', 'miracle': a lawfulness which we don't know yet
  - 'chaos': order of a higher law

## LAW in the Textbook

	WORD	CHRIST	CHRISTIANITY	SCIENCE
absolute Christian Science	God's law is the only law	all laws come from the law of God	alone God's laws rule the universe	letting God's law operate
Christian Science	<b>PRAYER</b> law remains law law as such	<b>ANIMAL MAGNETISM UNMASKED</b> there is no law against Spirit	<b>CREATION</b> God's laws operate universally	<b>TEACHING CHRISTIAN SCIENCE</b> the Christian Scientist is a law unto himself
<b>CHRIST</b> law's self-manifestation	<b>ATONEMENT AND EUCHARIST</b> the law of Spirit saves from the the law of matter	<b>SCIENCE, THEOLOGY, MEDICINE</b> God is the only lawgiver	<b>SCIENCE OF BEING</b> man is governed by spiritual, not by material laws	<b>RECAPITULATION</b> Christian Science fulfills the spiritual law of being, which resolves error
<b>CHRISTIANITY</b> the supremacy of the law	<b>MARRIAGE</b> the higher law governs	<b>PHYSIOLOGY</b> God's law annihilates material laws	<b>SOME OBJECTIONS ANSWERED</b> we must subordinate material laws to the spiritual laws	<b>GENESIS</b> the unerring Principle of the divine law unveils error as nothing
<b>SCIENCE</b> Science versus beliefs	<b>CHRISTIAN SCIENCE VERSUS SPIRITUALISM</b> law is independent of beliefs	<b>FOOTSTEPS OF TRUTH</b> only the laws of God matters; belief in material laws must be given up	<b>CHRISTIAN SCIENCE PRACTICE</b> alone the law of God, not a material law, can save	<b>THE APOCALYPSE</b> in God's law all is already fulfilled, all beliefs are compensated

## The laws of the 'Model of Being'

### Law of Science itself:

- *the law of infinite Being*
- the law of infinite Self-reflection

### Law of divine Science:

- *law of divine self-organization*
- the law of divine cybernetics

### Law of absolute Christian Science:

- *the law of divine spontaneity*
- the law of divine self-regulation

- Word:*
- *the law of divine impulsion*
  - the law of divine success-mechanism
  - the law of mutation
  - the law of the divine surprise
  - the law of infinite progression
  - the law of eternal newness

- Christ:*
- *the law of divine individualization*
  - the law of divine specialization
  - the law of infinite adaptation
  - the law of divine selectioning

- Christianity:*
- *the law of divine eternalization*
  - the law of self-maintenance
  - the law of divine reproduction

- Science:*
- *the law of prestabilized perfection*
  - the law of perfect preformation

### Law of Christian Science:

- *the law of divine causality*
- the law of divine self-correction of error

- Word:*
- *the law of creativity*
  - the law of divine illumination
  - the law of ordered evolution

- Christ:*
- *the law of translation and retranslation*
  - the law of transformation and reformation
  - the law of irresistible manifestation

- Christianity:*
- *the law of reflection*
  - the law of demonstration
  - the law of the self-annihilation of error

- Science:*
- *the law of structured understanding*

## **The Law of Being** **Law is a Principle of Being**

### **The law of the integral Oneness and Wholeness of Being**

- integral: constituting the whole
- parts do not exist, *per se*
- holism: the whole is greater than the sum of its parts
  - oneness is only possible through structural laws
  - structural laws result in meaningful wholeness
- chance, wonder, chaos: unknown laws of a higher order

### **The law of hierarchial order of all laws**

- translation of the One into the many
- every level has its own laws; these are secondary
- every level implies the other levels
- Beware: not to mix the levels

### **The law of fundamental translatability (transformation laws)**

- ascending: overforming of misunderstanding to understanding the infinite One
- descending: translation of the infinite One to the point of resolving misunderstanding

### **The law of self-organization: divine cybernetics**

- self-organizing
- self-structuring
- self-regulating
- self-correcting (mistake-friendly)

### **The law of optimizing**

- feedback: spiraling higher and higher

### **The law of synergy**

- dynamic cooperation of various structural laws or cybernetic laws

### **The law of complementarity**

- the 'as well as' law
- (Mary Baker Eddy: 'No and Yes')
- (quantum theory)

### **The law of dynamic equilibrium**

- equilibrium inspite of change
- "the Science which governs these changes" (S&H 224:6)
- homeorhese: stability in change

### **The law of redundancy**

- reduction of the many to the few
- categorizing



**Kappeler Institute for the Science of Being**

USA Information Center:

PO Box 99735, Seattle, WA 98199-0735

Tel. (206) 286-1617

FAX (206) 286-1675

E-mail: [mail@kappelerinstitute.org](mailto:mail@kappelerinstitute.org)

Website: [www.kappelerinstitute.org](http://www.kappelerinstitute.org)